

**SERVICE MANUAL**

# POLAR SERIES

**ASH-09AIP PT, ASH-12AIP PT**





---

<b>Summary and Features</b> .....	1
<b>Part 1 Safety Precautions</b> .....	2
<b>Part 2 Specifications</b> .....	3
2.1 Unit Specifications.....	3
2.2 Operation Characteristic Curve.....	7
2.3 Capacity Variation Ratio according to Temperature .....	7
2.4 Operation Date.....	8
2.5 Noise Criteria Curve Tables for both Models.....	8
<b>Part 3 Construction Views</b> .....	9
3.1 Indoor Unit .....	9
3.2 Outdoor Unit .....	10
<b>Part 4 Refrigerant System Diagram</b> .....	11
<b>Part 5 Schematic Diagram</b> .....	11
5.1 Electrical Data .....	11
5.2 Electrical Wiring.....	12
5.3 Printed Circuit Board.....	13
<b>Part 6 Function and Control</b> .....	18
6.1 Remote Control Operations.....	18
6.2 Changing Batteries and Notices.....	20
6.3 Description of Each Control Operation.....	22
<b>Part 7 Installation Manual</b> .....	28
7.1 Tools Required for Installation.....	28
7.2 Installation Position Selection.....	28
7.3 Installation of Indoor Unit.....	28
7.4 Installation of Outdoor Unit.....	32
7.5 Test Operation .....	33

---

<b>Part 8 Exploded Views and Parts List</b> .....	34
8.1 Indoor unit .....	34
8.2 Outdoor unit .....	38
<b>Part 9 Troubleshooting</b> .....	40
9.1 Precautions before Performing Inspection or Repair.....	40
9.2 Confirmation .....	40
9.3 Judgement by Flashing LED of Indoor/Outdoor Unit.....	40
9.4 How to Simply Check the Main Part.....	42
9.5 2-way, 3-way Valve Appearance .....	46
<b>Part 10 Removal Procedure</b> .....	53
10.1 Removal Procedure of Indoor Unit .....	53
10.2 Removal Procedure of Outdoor Unit .....	67
<b>Part 11 Care and Cleaning</b> .....	72

---



# Summary and Features

## Indoor Unit

ASH-09AIP PT  
ASH-09AIP PT

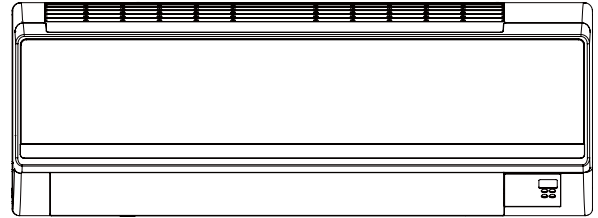

## Outdoor Unit

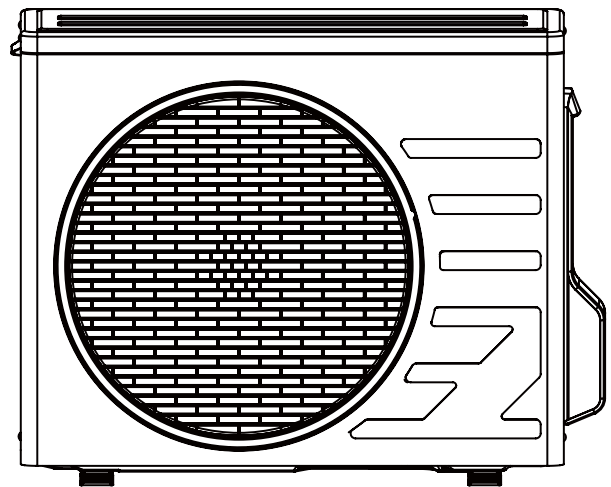

## Remote control

YB1F2



# 1. Safety Precautions

## Important!

### Please Read Before Starting

This air conditioning system meets strict safety and operating standards. As the installer or service person, it is an important part of your job to install or service the system so it operates safely and efficiently.

To prevent injury to the user or other people and property damage, the following instructions must be followed.

- Follow each installation or repair step exactly as shown.
- Observe all local, state, and national electrical codes.
- Pay close attention to all warning and caution notices given in this manual.

### About the pictures:



**Warning** Erroneous handling gives a high possibility to induce serious results such as death or heavy injury.



**Caution** Erroneous handling may induce serious injury depending on the situation.



## Warning

All electric work must be performed by licensed technician, according to local regulations and the instructions given in this manual.

- Do not supply power to the unit until all wiring and tubing are completed or reconnected and checked.
- Highly dangerous electrical voltages are used in this system. Carefully refer to the wiring diagram and these instructions when wiring. Improper connections and inadequate grounding can cause accidental injury or death.
- Ground the unit following local electrical codes.
- Connect all wiring tightly. Loose wiring may cause overheating at connection points and a possible fire hazard.

**There is risk of fire, electric shock, explosion, or injury.**

Ask your dealer or specialized subcontractor for installation or repair work.

- Make sure the ceiling/wall is strong enough to hold the unit's weight. The outdoor unit should be installed in a location where air and noise emitted by the unit will not disturb the neighbors.
- Properly insulate any tubing run inside a room to prevent "sweating" that can cause dripping and water damage to walls and floors.
- The outdoor unit must be installed on stable, level surface, in a place where there is no accumulation of snow, leaves

or rubbish.

- The unit should be installed according to the instructions in order to minimize the risk of damage from earthquakes, typhoons or strong winds.
- When the refrigerant touches the fire etc, it was decomposed and a poisonous gas is generated.
- Use only the specified refrigerant to charge the refrigerant circuit.
- Do not mix it with any other refrigerant and do not allow air to remain in the circuit.
- Air enclosed in the circuit can cause high pressure resulting in a rupture and other hazards.
- After completing installation work, make sure that refrigerant gas has not leaked.
- The limit density is made not to be exceeded even if the refrigerant leaks by any chance.
- Turn the power off at the main power box (mains) before opening the unit to check or repair electrical parts and wiring.
- Keep your fingers and clothing away from any moving parts.
- Clean up the site after you finish, remembering to check that no metal scraps or bits of wiring have been left inside the unit being serviced.
- The unit must be properly earth connected.



## Caution

- Never install on the place where a combustible gas might leak. The gas may ignite or explode when the gas leaks and collects in surround of the unit.
- When the unit is installed at telecommunication centers or hospitals, take a proper provision against noise.
- When installing at a watery place, provide an electric leak breaker.
- Do not wash the unit with water.
- Be very careful about unit transportation. The unit should not be carried by only one person if it is more than 20kg. It occasionally causes the damage of the unit and health to be impaired.
- Do not touch the heat exchanger fins with your hands. Doing so may cut your hands.
- Do not touch the compressor or refrigerant piping without wearing glove on your hands. Touching directly such part can cause a burn or frostbite as it becomes high or low temperature according to the refrigerant state.
- Do not operate the air conditioner without the air filter set place. Dust may accumulate, and cause a failure.
- At emergency (if you smell something burning), stop operation and turn the power source switch off.

## 2. Specifications

### 2.1 Unit Specifications

Model			ASH-09AIP PT	ASH-12AIP PT	
Product Code			CB14600300	CB14600310	
Power Supply	Rated Voltage	V~	220-240	220-240	
	Rated Frequency	Hz	50	50	
	Phases		1	1	
Power Supply Mode			Indoor	Indoor	
Cooling Capacity (Min~Max)		W	2650(450~3230)	3530(600~3960)	
Heating Capacity (Min~Max)		W	3520(450~4100)	4100(600~5130)	
Cooling Power Input (Min~Max)		W	800(200~1350)	1100(220~1450)	
Heating Power Input (Min~Max)		W	950(200~1450)	1135(220~1550)	
Cooling Power Current		A	3.55	4.88	
Heating Power Current		A	4.21	5.04	
Rated Input		W	1550	1650	
Rated Current		A	6.88	7.32	
Air Flow Volume(SH/H/M/L/SL)		m <sup>3</sup> /h	600/520/370/280/-	680/560/410/300/-	
Dehumidifying Volume		L/h	1	1.2	
EER		W/W	3.30	3.21	
COP		W/W	3.70	3.61	
SEER		W/W	/	/	
HSPF		W/W	/	/	
Application Area		m <sup>2</sup>	12-18	16-24	
Indoor Unit	Model of indoor unit		ASH-09AIP PT	ASH-12AIP PT	
	Fan Type		Cross-flow	Cross-flow	
	Diameter Length(DXL)		mm	Φ92X594	Φ92X594
	Fan Motor Cooling Speed (SH/H/M/L/SL)		r/min	1300/1100/900/700/-	1350/1150/950/750/-
	Fan Motor Heating Speed (SH/H/M/L/SL)		r/min	1300/1140/980/820/-	1350/1190/1020/850/-
	Output of Fan Motor		W	10	10
	Fan Motor RLA		A	0.16	0.16
	Fan Motor Capacitor		μF	1.2	1.2
	Input of Heater		W	0	0
	Evaporator Form			Aluminum Fin-copper Tube	Aluminum Fin-copper Tube
	Pipe Diameter		mm	Φ7	Φ7
	Row-fin Gap		mm	2-1.4	2-1.4
	Coil Length (LXDXW)		mm	610X24X294	610X24X294
	Swing Motor Model			MP24BA	MP24BA
	Output of Swing Motor		W	1.5	1.5
	Fuse		A	PCB 3.15A	PCB 3.15A
	Sound Pressure Level (SH/H/M/L/SL)		dB (A)	41/38/30/24/-	42/39/31/25/-
	Sound Power Level (SH/H/M/L/SL)		dB (A)	51/48/40/34/-	52/49/41/35/-
	Dimension (WXHXD)		mm	770X283X201	770X283X201
	Dimension of Carton Box (L/W/H)		mm	844X342X261	844X342X261
	Dimension of Package (L/W/H)		mm	847X345X276	847X345X276
	Net Weight		kg	8	9
	Gross Weight		kg	11	12

Outdoor Unit	Model of Outdoor Unit		ASH-09AIP PT	ASH-12AIP PT
	Compressor Manufacturer/Trademark		Daikin Compressor Industries /daikin	Daikin Compressor Industries/daikin
	Compressor Model		1YC23AEXD	1YC23AEXD
	Compressor Oil		DAPHEN FVC50K	DAPHEN FVC50K
	Compressor Type		Rotary	Rotary
	L.R.A.	A	4	4
	Compressor RLA	A	4	4
	Compressor Power Input	W	600W	600W
	Overload Protector		CS-7SA	CS-7SA
	Throttling Method		Capillary	Capillary
	Operation temp	℃	16~30	16~30
	Ambient temp (cooling)	℃	-15-46	-15-46
	Ambient temp (heating)	℃	-15-24	-15-24
	Condenser Form		Aluminum Fin-copper Tube	Aluminum Fin-copper Tube
	Pipe Diameter	mm	Φ7	Φ7
	Rows-fin Gap	mm	1-1.4	2-1.4
	Coil Length (LXD <sub>X</sub> W)	mm	647X19.05X528	647X38.1X528
	Fan Motor Speed	rpm	930	930
	Output of Fan Motor	W	30	30
	Fan Motor RLA	A	0.236	0.236
	Fan Motor Capacitor	μF	2	2
	Air Flow Volume of Outdoor Unit	m <sup>3</sup> /h	1600	1600
	Fan Type		Axial-flow	Axial-flow
	Fan Diameter	mm	370	370
	Defrosting Method		Automatic Defrosting	Automatic Defrosting
	Climate Type		T1	T1
	Isolation		I	I
	Moisture Protection		IP24	IP24
	Permissible Excessive Operating Pressure for the Discharge Side	MPa	3.8	3.8
	Permissible Excessive Operating Pressure for the Suction Side	MPa	1.2	1.2
	Sound Pressure Level (H/M/L)	dB (A)	51/-/-	53/-/-
	Sound Power Level (H/M/L)	dB (A)	61/-/-	63/-/-
Dimension (WXHXD)	mm	710X318X550	710X318X550	
Dimension of Carton Box (L/W/H)	mm	771X348X592	771X348X592	
Dimension of Package (L/W/H)	mm	774X351X607	774X351X607	
Net Weight	kg	28	30	
Gross Weight	kg	32	34	
Refrigerant		R410A	R410A	
Refrigerant Charge	kg	0.74	1	
Connection Pipe	Length	m	5	5
	Gas Additional Charge	g/m	30	20
	Outer Diameter Liquid Pipe	mm	Φ6	Φ6
	Outer Diameter Gas Pipe	mm	Φ9.52	Φ9.52
	Max Distance Height	m	10	10
	Max Distance Length	m	15	20

The above data is subject to change without notice. Please refer to the nameplate of the unit.

## 2.2 Operation Characteristic Curve

Cooling

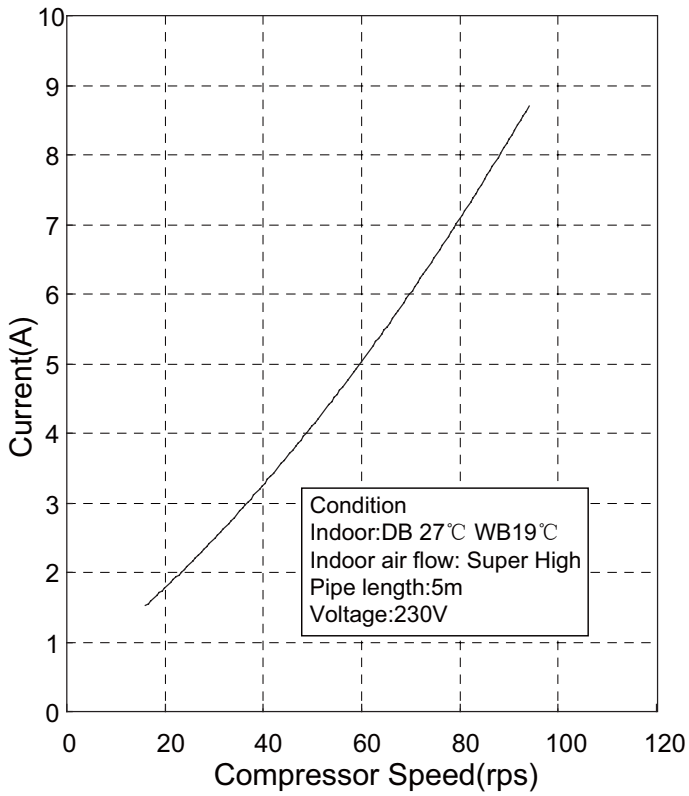

Heating

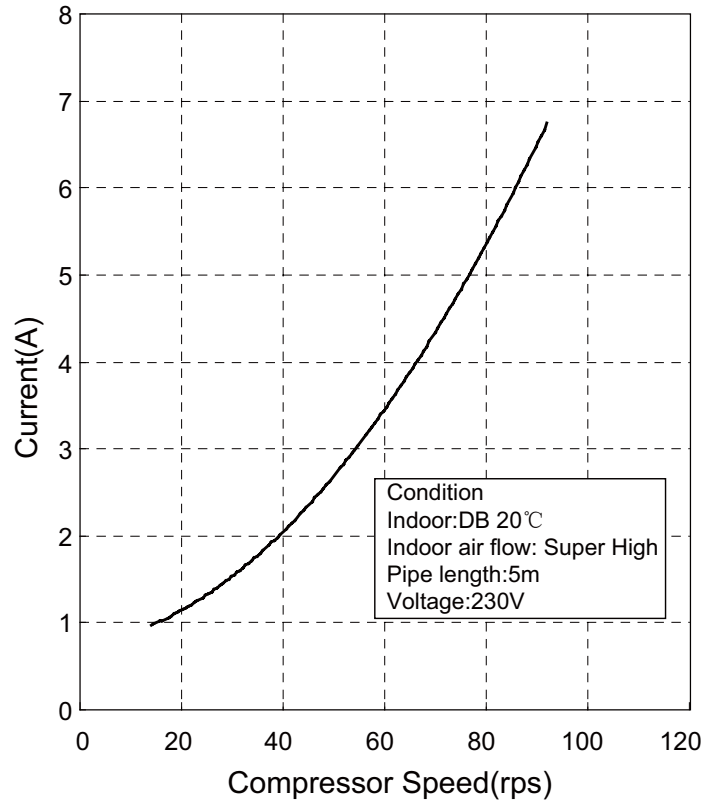

## 2.3 Capacity Variation Ratio according to Temperature

Cooling

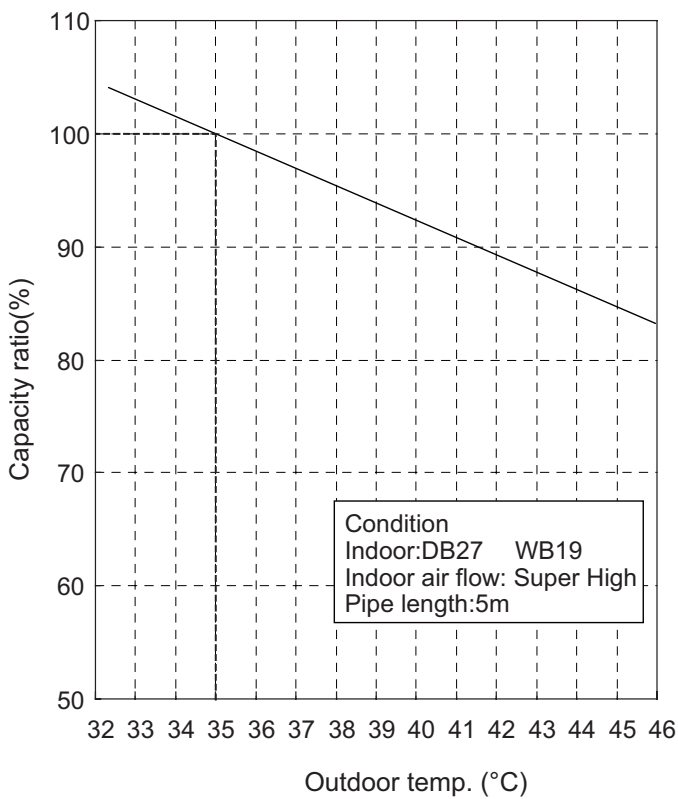

Heating

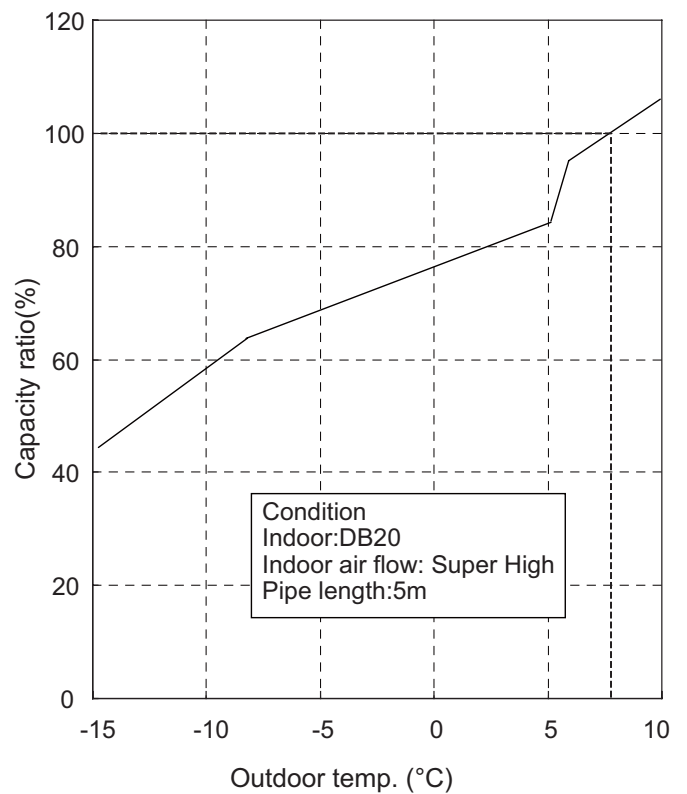

## 2.4 Operation Data

### Cooling

Temperature condition (°C)		Model name	Standard pressure	Heat exchanger pipe temp		Indoor fan mode	Outdoor fan mode	Compressor revolution (rps)
Indoor	Outdoor			P (MPa)	T1 (°C)			
27/29	35/24	09K	0.9 to 1.1	10~13/13~15	60~65/37~43	Super High	Super High	53
		12K	0.8 to 1.0	9~12/12~15	60~65/37~43	Super High	Super High	72

### Heating

Temperature condition (°C)		Model name	Standard pressure	Heat exchanger pipe temp		Indoor fan mode	Outdoor fan mode	Compressor revolution (rps)
Indoor	Outdoor			P (MPa)	T1 (°C)			
20/-	7/6	09K	2.2 to 2.4	60~65/25~30	0~4/0~5	Super High	Super High	62
		12K	2.5 to 2.7	60~65/25~30	0~4/0~5	Super High	Super High	78

P: Pipe pressure connecting indoor and outdoor unit;  
 T1: Inlet and outlet pipe temperature of evaporator;  
 T2: Inlet and outlet pipe temperature of condenser.

#### NOTES :

- (1) Measure surface temperature of heat exchanger pipe around center of heat exchanger path U bent. (Thermistor thermometer)
- (2) Connecting piping condition : 5 m

## 2.5 Noise Criteria Curve Tables for both Models

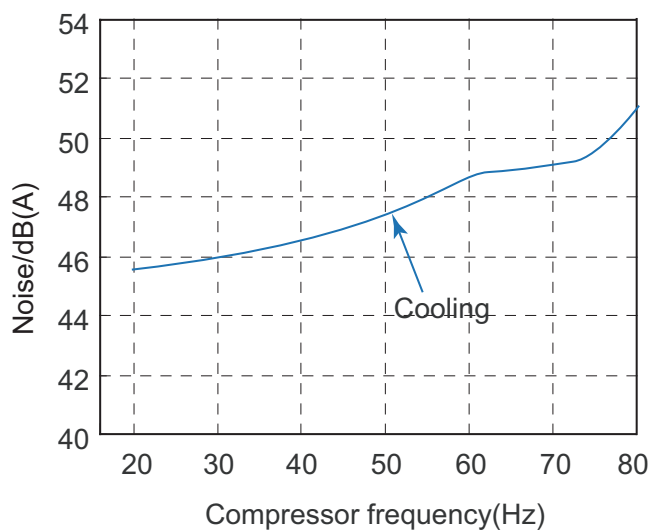
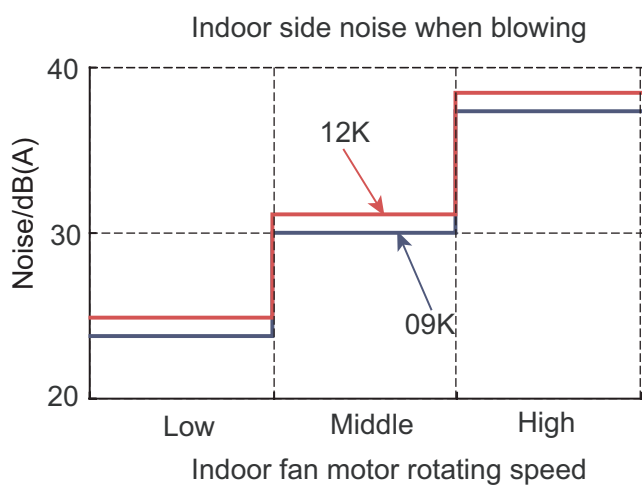

### 3. Construction Views

#### 3.1 Indoor Unit

Models ASH-09AIP PT, ASH-12AIP PT

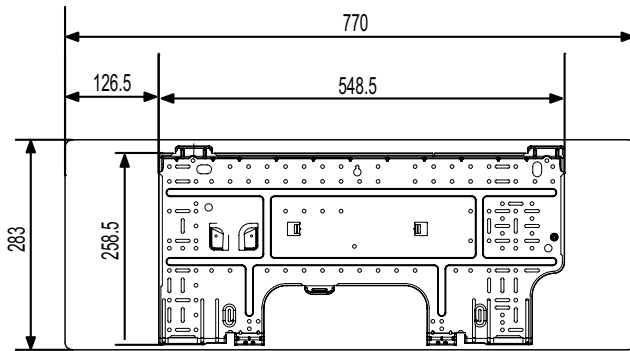
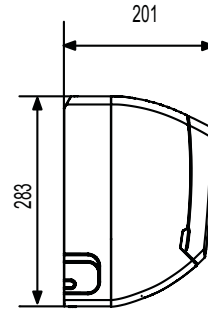
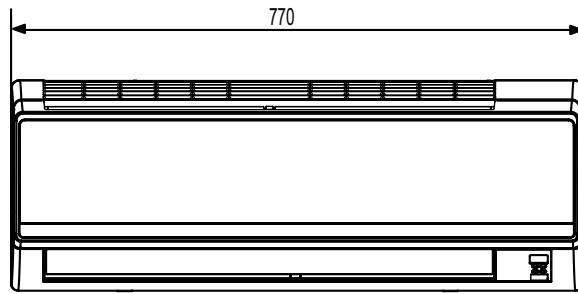

Unit:mm

### 3.2 Outdoor Unit

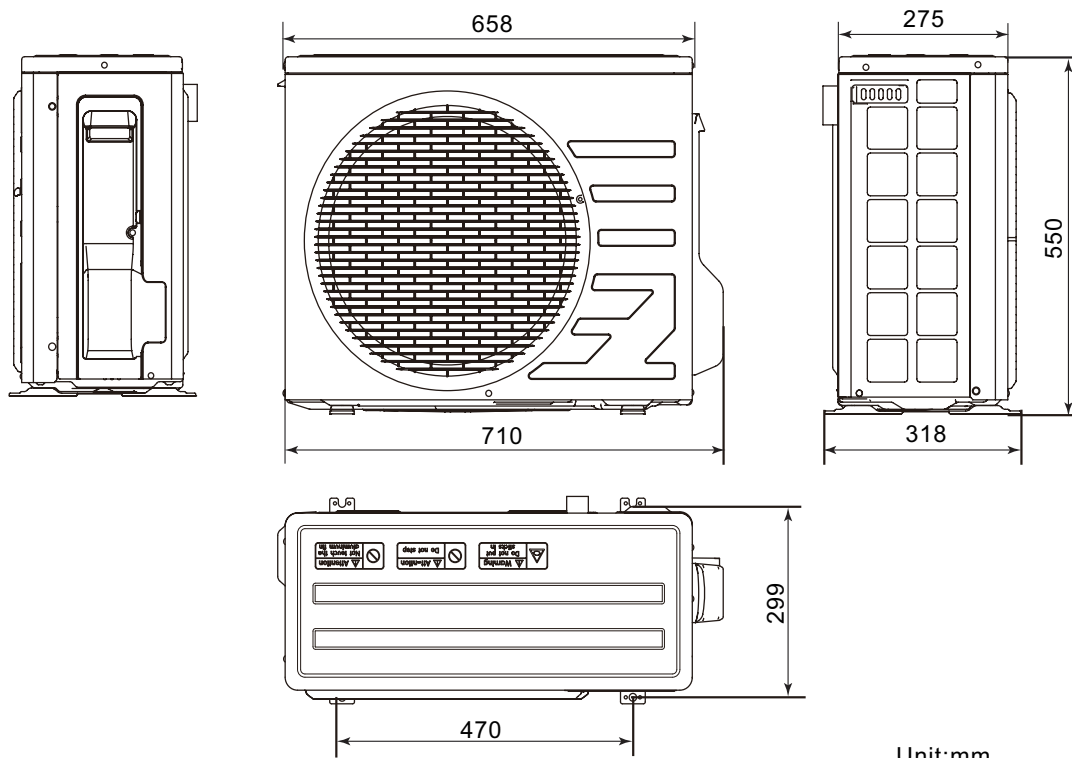



## 4. Refrigerant System Diagram

### Cooling and Heating Model

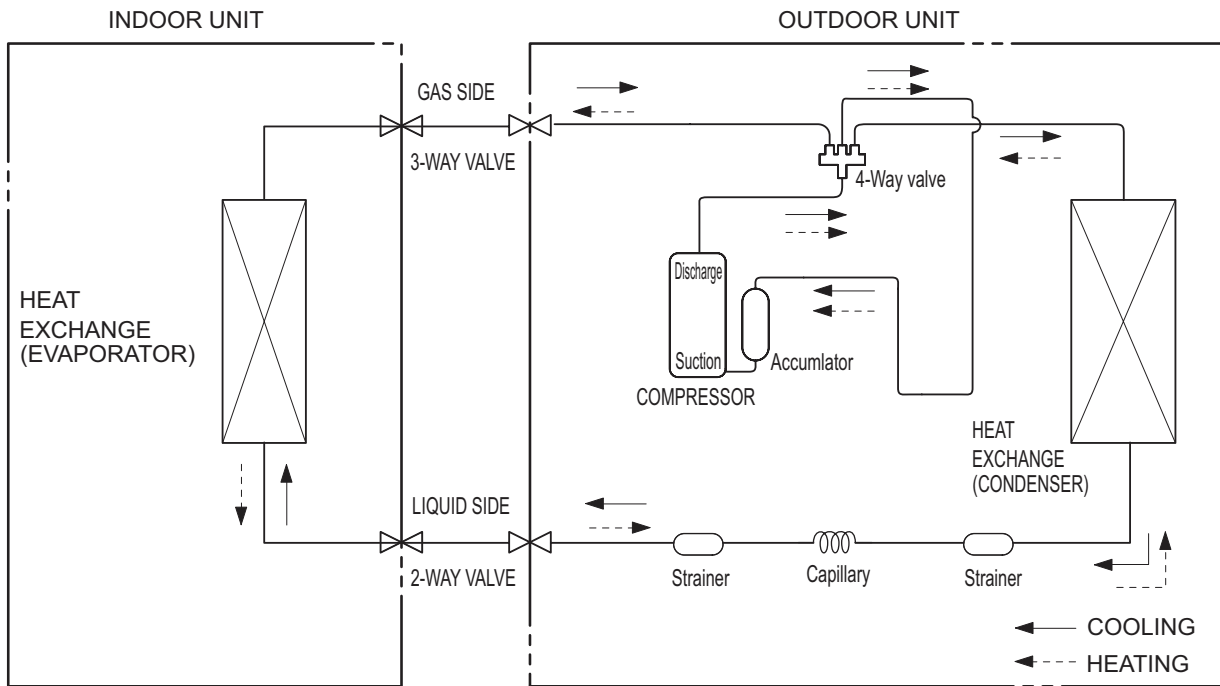

Refrigerant pipe diameter  
 Liquid : 1/4" (6 mm)  
 Gas : 3/8" (9.52 mm)

## 5. Schematic Diagram

### 5.1 Electrical Data

#### Meaning of marks

#### ● Indoor Unit

Symbol	Color symbol	Symbol	Color symbol
WH	WHITE	BN	BROWN
YE	YELLOW	BU	BLUE
RD	RED	BK	BLACK
YEGN	YELLOW GREEN	⊕	PROTECTIVE EARTH

#### ● Outdoor Unit

Symbol	Parts name	Symbol	Color symbol
L1	REACROR	WH	WHITE
PCB1~PCB2	PRINTED CIRCUIT BOARD	YE	YELLOW
S10/S11S40/S70/S80/S90	CONNECTOR	RD	RED
SAT	OVERLOAD	BN	BROWN
COMP	COMPRESSOR	BU	BLUE
⊕	PROTECTIVE EARTH	BK	BLACK
YEGN	YELLOW GREEN		

## 5.2 Electrical Wiring

### ● Indoor Unit

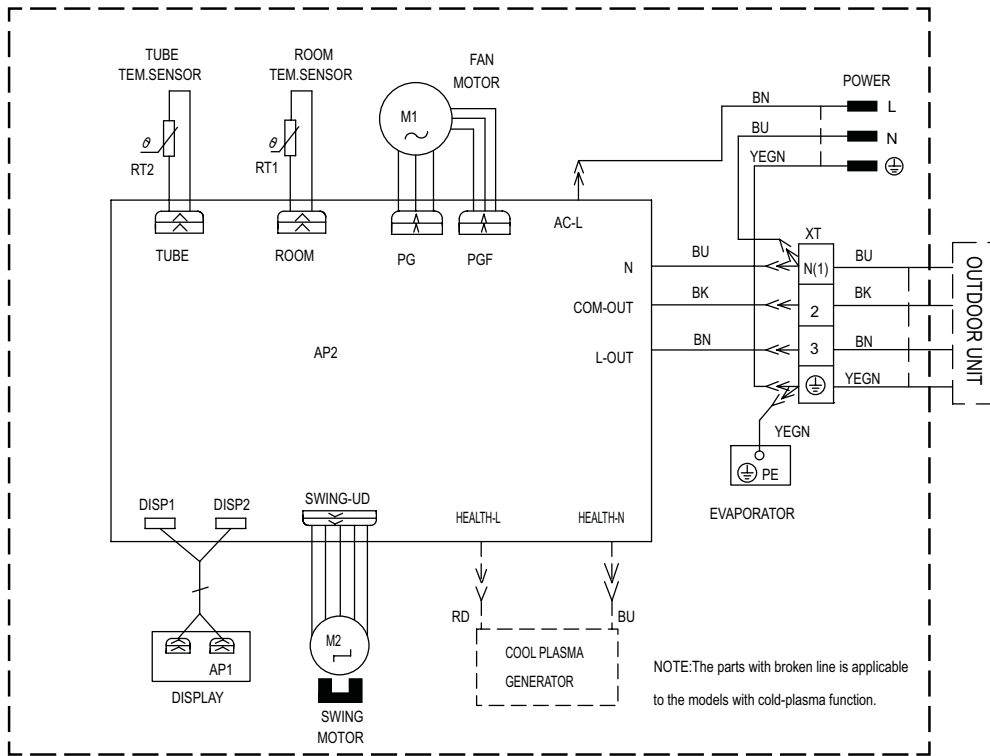

### ● Outdoor Unit

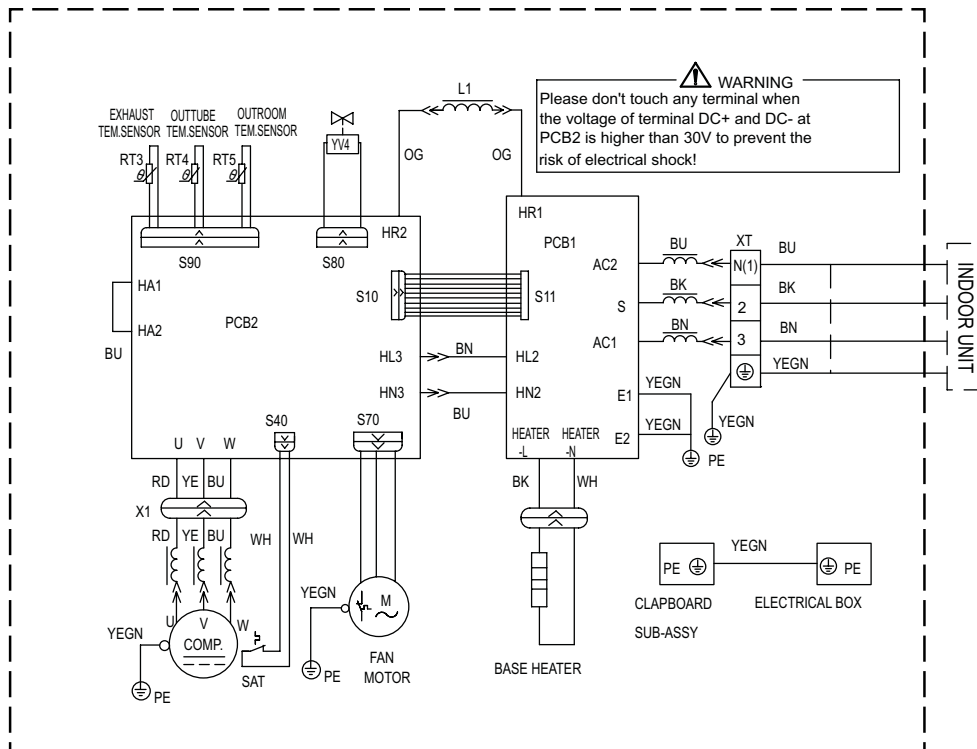

These circuit diagrams are subject to change without notice. Please refer to the one supplied with the unit.

### 5.3 Printed Circuit Board

Indoor Unit

(1) Control PCB

● TOP VIEW

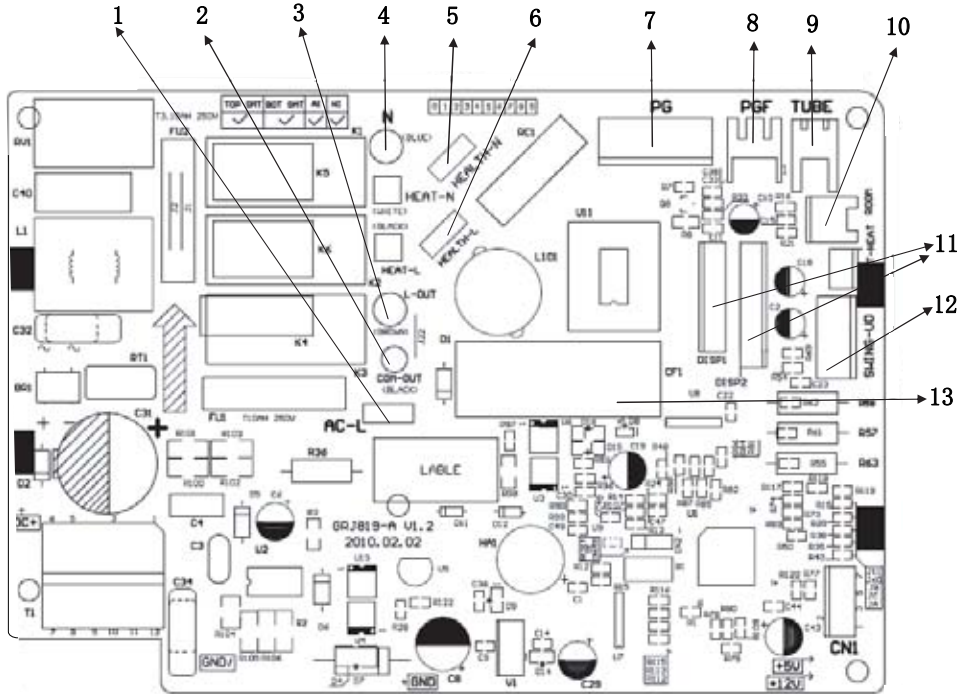

1. Interface of input live wire.
2. Interface of communication wire.
3. Interface of output live wire.
4. Interface of input neutral wire.
5. Neutral wire interface of cold plasma.
6. Live wire interface of cold plasma.
7. Interface of indoor fan.
8. Interface feedback from indoor fan.
9. Interface of pipe temperature sensor.
10. Interface of ambient temperature sensor.
11. Display interface.
12. Interface of air motor.
13. Fan capacity.

● BOTTOM VIEW

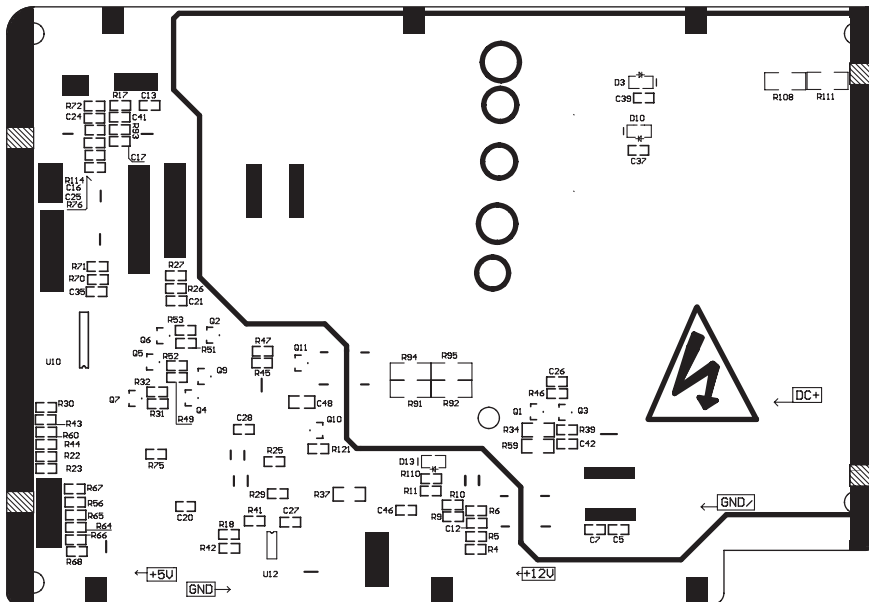

(2) Display PCB & Power Supply PCB

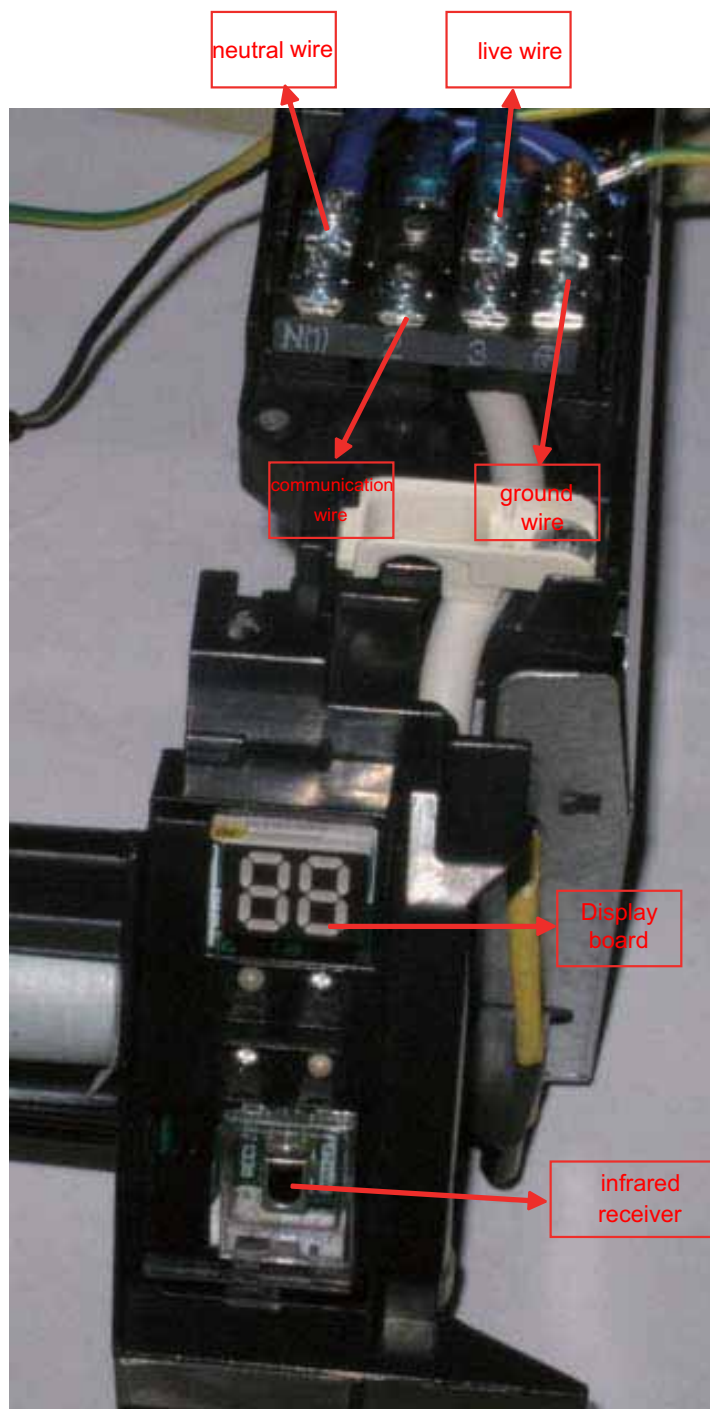

**Schematic Diagram**

**Outdoor Unit  
(1)Control PCB  
● TOP VIEW**

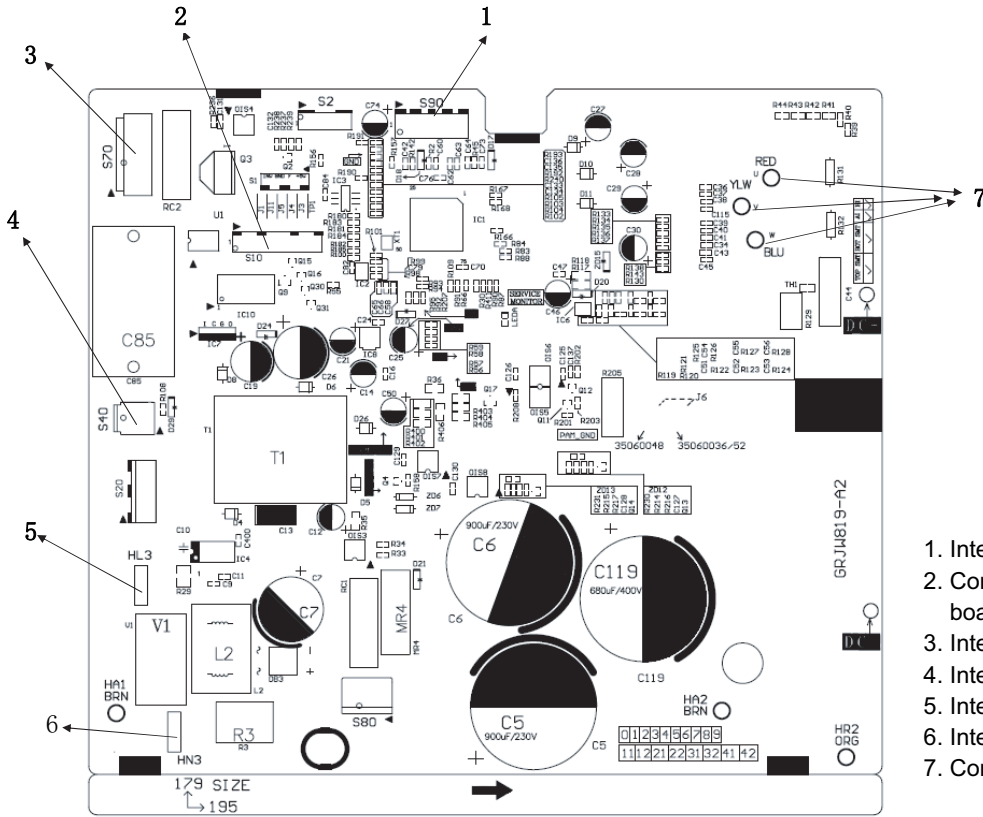

1. Interface of temperature sensor
2. Connection interface of mainboard and filtering board
3. Interface of outdoor fan
4. Interface of compressor overload
5. Interface of live wire
6. Interface of neutral wire
7. Compressor control interface

**● BOTTOM VIEW**

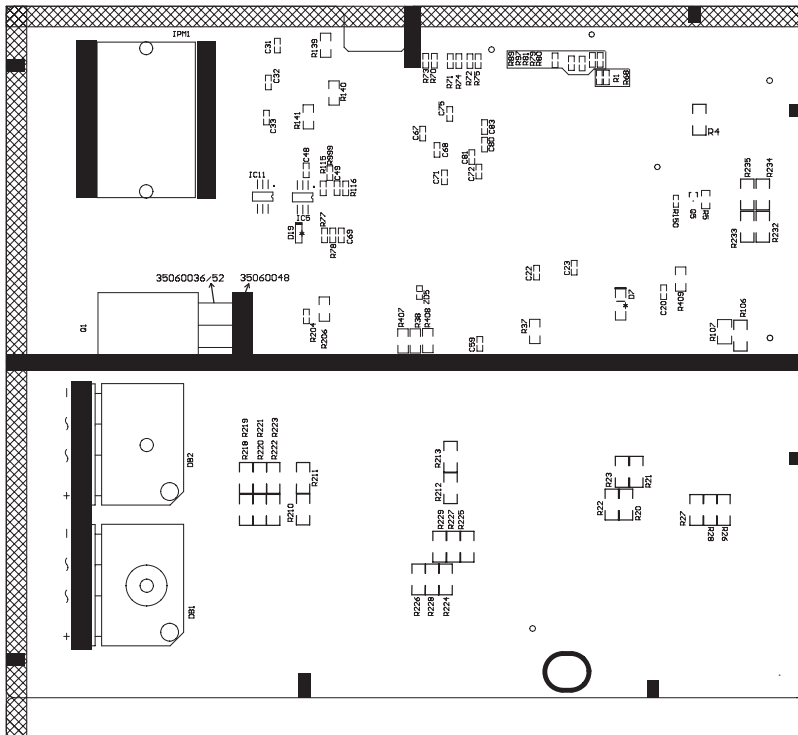

(2) Power Supply PCB

● FRONT VIEW



● BOTTOM VIEW

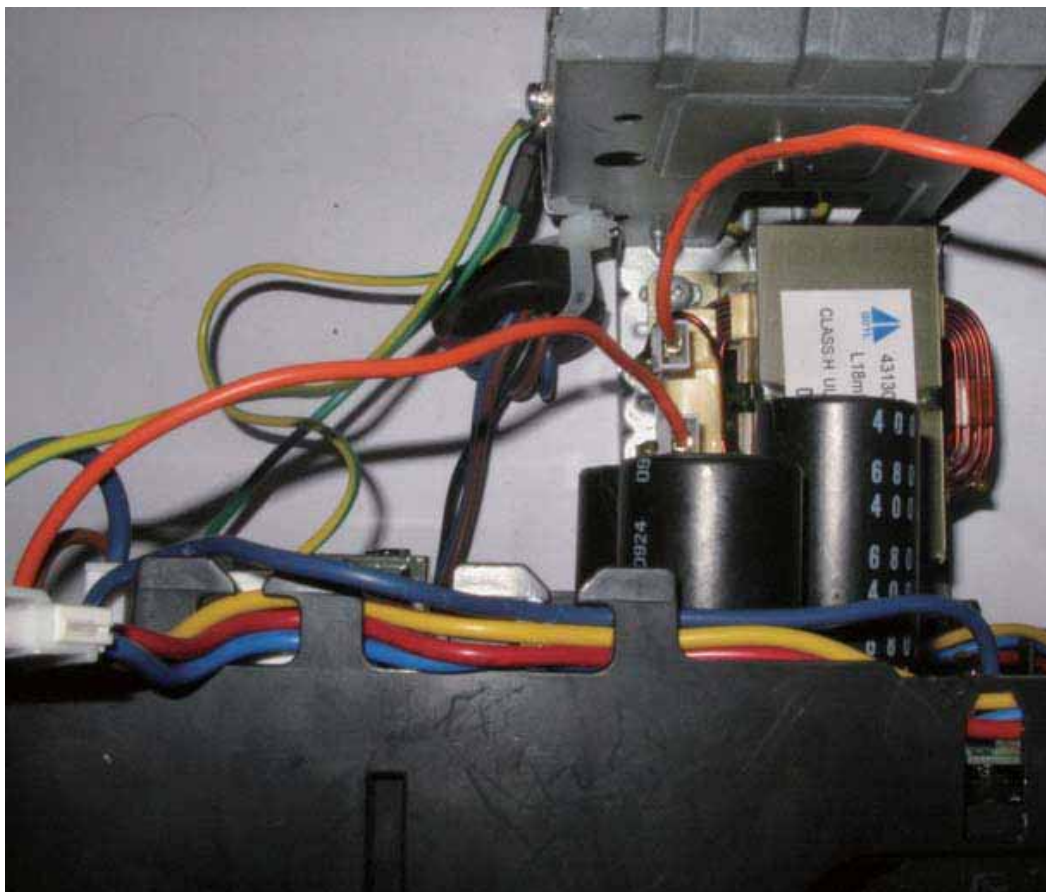

Schematic Diagram

(3)Rejector PCB

● TOP VIEW

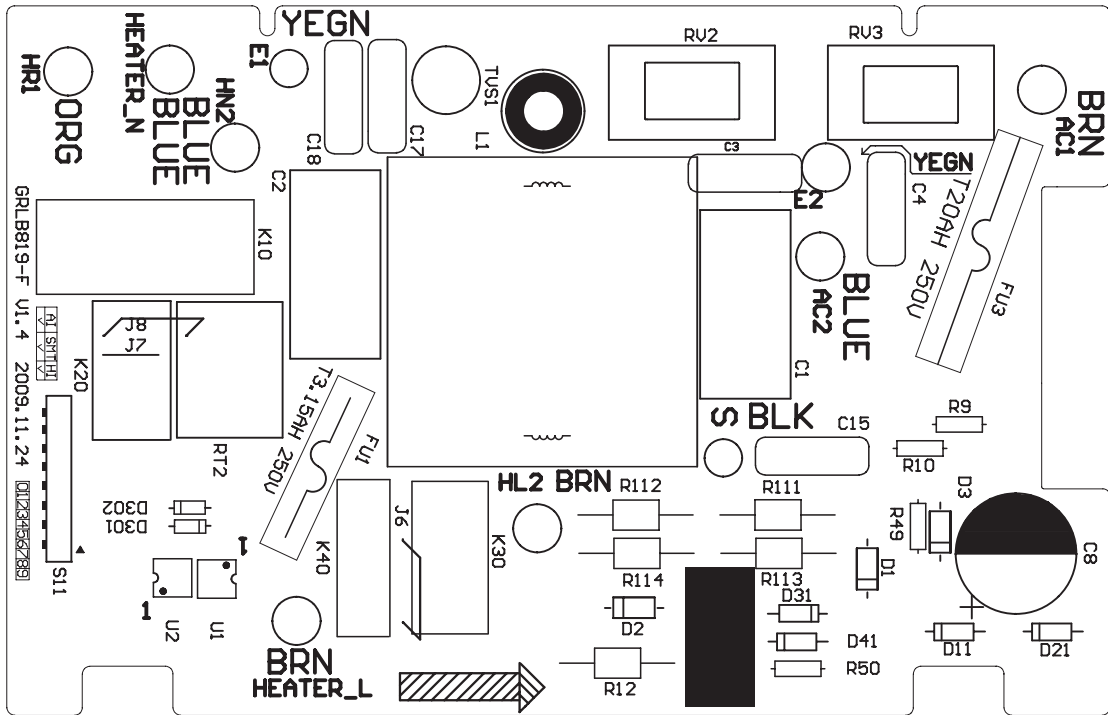

● BOTTOM VIEW

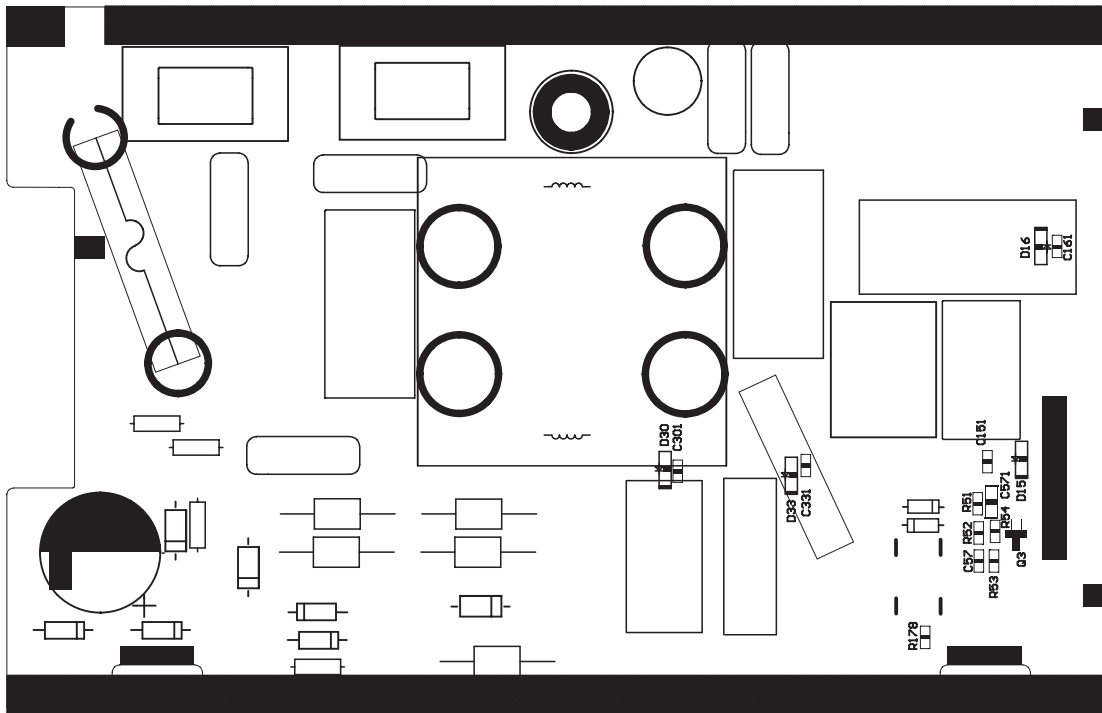



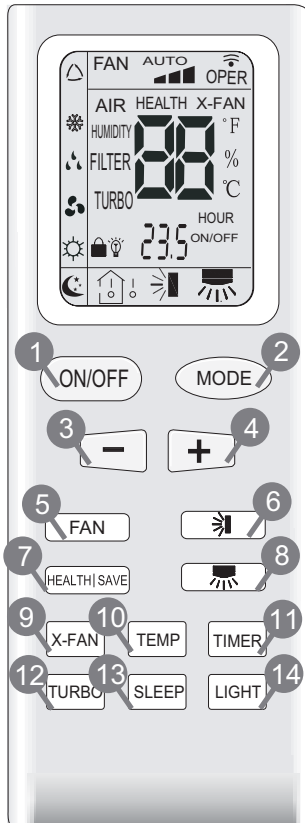

## 6. Function and Control

### 6.1 Remote Control Operations



- 1 ON/OFF**  
Press this button to start or stop operation.
- 2 MODE**  
Press it to select operation mode(AUTO/COOL/DRY/FAN/HEAT).
- 3 -** : Press it to decrease temperature setting.
- 4 +** : Press it to increase temperature setting.
- 5 FAN**  
Press it to set fan speed.
- 6**   
Press it to set up &down swing angle.
- 7 HEALTH|SAVE**  
Press it to select health mode on or off.
- 8**   
Press it to set left & right swing angle.
- 9 X-FAN**(X-FAN is the alternative expression of BLOW for the purpose of understanding.)
- 10 TEMP**
- 11 TIMER**  
Press it set auto-on timer/auto-off timer.
- 12 TURBO**
- 13 SLEEP**
- 14 LIGHT**  
Press it to turn on/off the light.

#### Remote controller description

- 1 ON/OFF** :  
Press this button to start the unit operation .Press this button again to stop the unit operation.
- 2 MODE** :  
Each time you press this button,a mode is selected in a sequence that goes from AUTO, COOL,DRY, FAN, and HEAT\*, as the following



\*Note:Only for models with heating function.

After energization, AUTO mode is defaulted. In AUTO mode, the set temperature will not be displayed on the LCD, and the unit will automatically select the suitable operation mode in accordance with the room temperature to make indoor room comfortable.





**3** —:

Press this button to decrease set temperature. Holding it down above 2 seconds rapidly decreases set temperature. In AUTO mode, set temperature is not adjustable.

**4** + :





Press this button to increase set temperature. Holding it down above 2 seconds rapidly increases set temperature. In AUTO mode, set temperature is not adjustable.

**5** FAN:

This button is used for setting fan speed in the sequence that goes from AUTO, , , to , then back to Auto.



**6** :

- Press  button to start or stop up & down swing function. The remote controller defaults to simple swing condition.
- Press + button and  button at the same time at unit OFF to switch between simple swing and static swing,  blinking 2 seconds.
- In static swing condition, press  button, the swing angle of up & down louver changes as below:







- If the unit is turned off during swing operation, the louver will stop at present position.

**7** HEALTH|SAVE:

Press HEALTH part of this button to turn on or off HEALTH function. Pressing SAVE part of this button,  is displayed and the unit goes into SAVE operation mode. Press SAVE part of the button again to cancel SAVE function. During SAVE operation, the temperature and fan speed is not adjustable.

**8** :

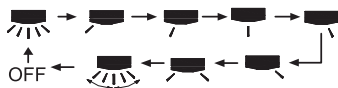

- Press  button to start or stop left & right swing function. The remote controller defaults to simple swing condition.
- Press + button and  button at the same time at unit OFF to switch between simple swing and static swing,  blinking 2 seconds..
- In static swing condition, press  button, the swing angle of left & right louver changes as below:



- If the unit is turned off during swing operation, the louver will stop at present position.

**9** X-FAN:

Pressing X-FAN button in COOL or DRY mode, the icon "X-FAN" is displayed and the indoor fan will continue operation for 10 minutes in order to dry the indoor unit even though you have turned off the unit. After energization, X-FAN OFF is defaulted. X-FAN is not available in AUTO, FAN or HEAT mode.



**10 TEMP:**  
Pressing TEMP button,  (set temperature),  (indoor ambient temperature) and  (outdoor ambient temperature) is displayed circularly. The unit defaults not to display the icon. During operation of TEMP button, the set temperature is always displayed.



Note: Outdoor ambient temperature is only displayed for some models.

**11 TIMER:**  
Press TIMER button at unit ON to set TIMER OFF, HOUR OFF blinking. Press TIMER button at unit OFF to set TIMER ON, HOUR ON blinking. In this case, pressing + or - button changes time setting. Holding down either button rapidly changes time setting (time setting range 0.5-24hours). Press TIMER button again to confirm setting, HOUR ON/OFF stopping blink. If there is not any operation of button within 5 seconds during HOUR ON/OFF blinking, TIMER setting will be canceled.

**12 TURBO:**  
Press this button to activate / deactivate the Turbo function which enables the unit to reach the preset temperature in shortest time. In COOL mode, the unit will blow strong cooling air at super high fan speed. In HEAT mode, the unit will blow strong heating air at super high fan speed. (This function is not applicable for some models).

**13 SLEEP :**  
Press this button to go into the SLEEP operation mode. Press it again to cancel. This function is available in COOL , HEAT (Only for models with heating function) or DRY mode to maintain the most comfortable temperature for you.

**14 LIGHT:**  
Press LIGHT button to turn on the display's light and press this button again to turn off the display's light. If the light is turned on,  is displayed. If the light is turned off  disappears.

**4** and **3** About lock :  
Press "+ " and "- " buttons simultaneously to lock or unlock the keypad. If the remote controller is locked,  is displayed. In this case, pressing any button,  blinks three times.

**3** and **2** About switch between fahrenheit and cenrigrade  
At unit OFF, press "MODE" and "- " buttons simultaneously to switch between °C and °F .

## 6.2 Changing batteries and notices

- 1.Remove the battery cover plate from the rear of the remote controller. (As shown in the figure).
- 2.Take out the old batteries.
- 3.Insert two new AAA1.5V dry batteries, and pay attention to the polarity.
4. Reinstall the battery cover plate.

### Notes:

- When replacing the batteries, do not use old or different batteries, otherwise, it may cause malfunction.
- If the wireless remote controller will not be used for a long time, please remove batteries to prevent damage from leaking batteries.
- The operation should be performed in its receiving range.
- It should be kept 1m away from the TV set or stereo sound sets.
- If the wireless remote controller does not operate normally, please take the batteries out and replace them after 30 seconds. If it still can't operate properly, replace the batteries.

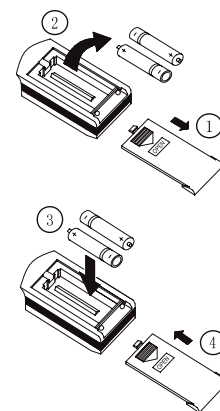

Sketch map for replacing batteries

## ● Unit indication section

1. When the unit is energized, all the display marks will be shown and only the RUN LED lights.
2. When the unit is turned on remotely, the RUN LED goes out while the current setting running mode is displayed.
3. During defrosting, "H1" is displayed in "dual 8" place.
4. In normal situation, the setting temperature is displayed in "dual 8" place.
5. When the signal of displaying indoor temperature or outdoor temperature is received from the controller, the corresponding temperature will be shown in "dual 8" place. It resumes displaying setting temperature 5s later.

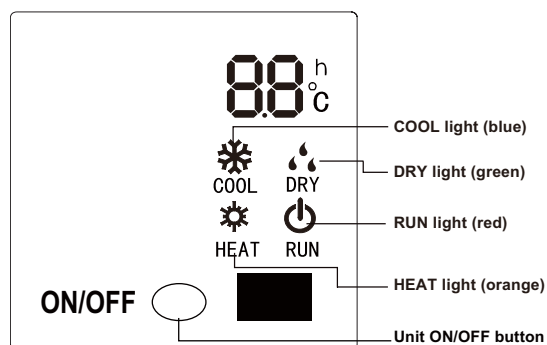

## ● Unit ON/OFF button

**If the wireless remote control is lost or broken, please use the manual switch button. At this time, the unit will run at the Auto mode, but the temperature and fan speed cannot be changed. The operation was shown as below:**

To open the panel, the manual switch is on the displayer box.

- Turn on the unit: At unit turned off, press the button, the unit will run at Auto mode immediately. The microcomputer will accord to the indoor temperature to select (Cooling, Heating, Fan) and obtain the comfortable effect.
- Turn off the unit: At unit turned on, press the button, the unit will stop working.

Operation of auto button:

	less than 5s	keep 5 ~ 10 s	keep more than 10s
operation during stop	start running	start force running	stop force running (avoid button lock)
operation during running	stop running	stop running	
operation during stop (communication error)	(after running, abnormal)		

## DESCRIPTION OF EACH CONTROL OPERATION

### (1) COOLING MODE

- When room temperature-preset temperature  $\leq -2^{\circ}\text{C}$ , the unit stops running; the outdoor fan will delay the stop running, indoor fan runs at the preset fan speed;
- When room temperature-preset temperature  $> -2^{\circ}\text{C}$ , during a certain period, if (room temperature-preset temperature)  $> -2^{\circ}\text{C}$  for a long time, the unit start to run, and the indoor fan, outdoor fan and compressor runs, indoor fan runs at the preset fan speed.

\* Under this mode, fan and swing runs at preset state, the temperature setting ranges is  $16\sim 30^{\circ}\text{C}$  ( $61\sim 86^{\circ}\text{F}$ ).

\* If there is malfunction of outdoor unit or stop, the indoor unit keeps the original state and display malfunction indication.

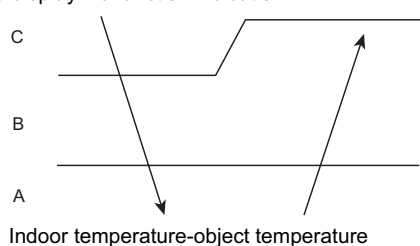

### (2) DRY MODE

- In this mode, the fan motor runs at low fan speed while swing works according to setting state. The range of setting temperature is  $16\sim 30^{\circ}\text{C}$  ( $61\sim 86^{\circ}\text{H}$ ).
- When outdoor malfunction or protection stoppage happen, the indoor fan will remain the original running state and the error LED will light.

### (3) FAN MODE

- In this mode, the indoor fan may run at high, medium, low and automatic speed. The compressor, outdoor fan and 4-way valve all stop running.
- In this mode, the range of setting temperature is  $16\sim 30^{\circ}\text{C}$  ( $61\sim 86^{\circ}\text{H}$ ).

### (4) HEATING MODE

- Heating mode

When setting temperature-indoor temperature  $\leq -1.5^{\circ}\text{C}$ , the unit will stop heating. Both outdoor fan and indoor fan will stop later.

When setting temperature-indoor temperature  $> -1.5^{\circ}\text{C}$  and it lasts for a certain period, the unit will start heating. In that case, indoor fan, outdoor fan and compressor will start running. The indoor fan works according to the anti-cold air.

\* In this mode, the range of setting temperature is  $16\sim 30^{\circ}\text{C}$  ( $61\sim 86^{\circ}\text{H}$ ).

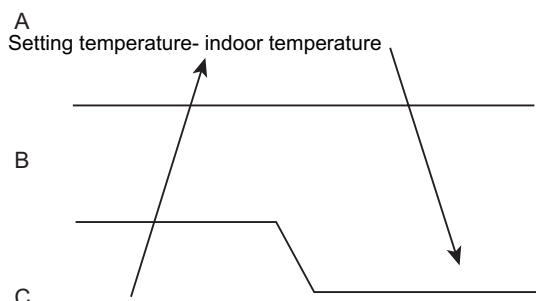

- Protection function: in heating mode, when the compressor stops as a result of malfunction, the indoor fan blows residual heat.
- Defrosting control: when the defrosting signal is revived, the defrosting mark H1 will be shown. The e-heater and indoor fan stop.

### \* Anti-cold air function

The rotational speed of indoor electromotor is decided based on the indoor pipe temperature. The indoor fan can run at low speed or stop running. This function will terminate after the unit runs for 3min or the pipe temperature reached certain value.

During heating, if the indoor pipe temperature is lower than certain value.

The running speed of indoor fan will decrease automatically base on the pipe temperature and ensure that the outlet air is hot.

### \* Residual heat blowing function

During heating, when the stopping condition for the compressor is reached, the compressor and the outdoor fan motor stop running while the upper and lower air deflector rotate to level L. the indoor fan will stop after running for 60s at setting speed.

### (5) AUTO CHANGEOVER MODE

In this mode, the system selects the running mode (cooling, heating, and fan) automatically according to the ambient temperature. The display shows the actual running mode and setting temperature. There will be 30s delay for mode conversion. The protection function is the same as that of other modes.

- When  $T_{\text{amb}} \geq 25^{\circ}\text{C}$ , the cooling mode is selected.
- for heat pump unit: when  $T_{\text{amb}} \leq 22^{\circ}\text{C}$ , the unit runs in heating mode
- for cooling only unit: when  $T_{\text{amb}} < 22^{\circ}\text{C}$ , the unit runs in fan mode. .
- When  $22^{\circ}\text{C} < T_{\text{indoor amb}} < 25^{\circ}\text{C}$ , upon initial startup, the unit will enter auto mode and run in automatic fan mode. If the other mode changes into auto mode, the previous running mode will remain.

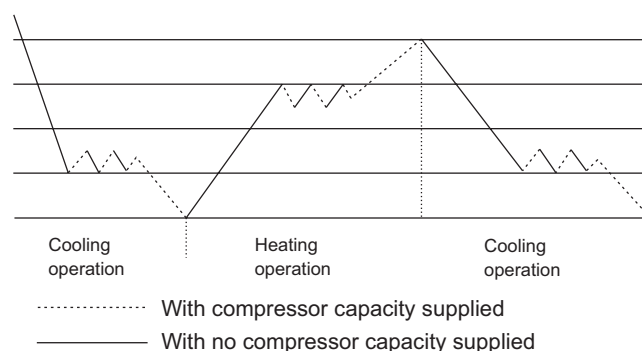

### (6) AUTO FAN SPEED MODE

In auto fan speed mode, the rotational speed of the fan for indoor unit is decided by the differential temperature between ambient temperature and setting temperature. In dehumidifying mode, the automatic fan speed is forced to be low.

### INDOOR FAN CONTROL

No. of jumper cap	unit type	mode	Super-high fan speed	High fan speed	Medium fan speed	Low fan speed
1	09K	Rotational speed during cooling	1300	1100	900	700
2	12K	Rotational speed during cooling	1350	1150	950	750

**(7)LOUVER CONTROL**

After energization, the motor of upper and lower swing will enable the air deflector to be open and then be close completely. And the air outlet is close. In heating mode, if the swing function is not set, the upper and lower air deflector will rotate to maximum in clockwise direction. Then it will rotate to place D. Under other state, the upper and lower air deflector will rotate to level L. If the swing function is set when starting the unit, the air deflector will swing between place L and D. there are 7 states for air deflector: in Place L, Place A, Place B, Place C, Place D, and swing between Place L and place D, stop in any place between Place L and place D. When the unit is turned off, the air deflector will stay in place 0. The swing is available only when the swing function is set and the indoor fan is running.

Note: When place L to B, place A to C, and place B and D is set, the air deflector will swing between place L to D.

L ↔ A ↔ B ↔ C ↔ D

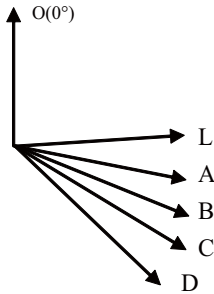

**(8)SLEEP FUNCTION**

1. It is applicable to cooling mode, dehumidifying mode and heating mode.
2. In cooling mode or dehumidifying mode, 1 hour after the sleep curve is set, the setting temperature will rise by 1 °C . 2 hours later, the setting temperature will rise by 2 °C . After that, the setting temperature will not change any more

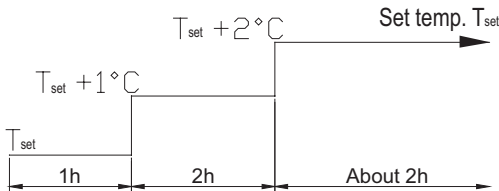

3. In heating mode, 1 hour after the sleep curve is set, the setting temperature will decrease by 1 °C . 2 hours later, the setting temperature will decrease by 2 °C . After that, the setting temperature will not change any more.

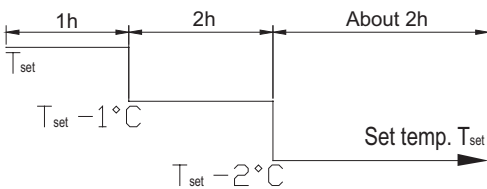

**(10)TIMER FUNCTION**

The main board has general timer function and clock function. The timer function can be selected by remote controller with different function

- (1) General timer (start and stop time can be set. The accuracy is minute. E.g.: timer on for 1 hour; timer off for 1.5 hours.)

Timer on: after setting timer on, the unit will run at setting time according to the original setting mode. The timing interval is 0.5hour, and the setting range is 0.5~24hours.

Timer off: the timer off function can be set when the unit is on. When the setting time for timer off is reached, the unit will stop. The timing interval is 0.5hour, and the setting range is 0.5~24hours.

- (2)Clock (start and stop time can be set. The accuracy is minute. E.g.: timer on at 8:00a.m.; timer off at 17:30p.m.)

Timer on: if the timer on function is set when the system is on, the system will go on running. If the timer on function is set when the system is off, the system will start running in the previously set mode when the setting time is reached.

Timer off: if the timer off function is set when the system is off, the system will keep off even though the setting time is reached. If the timer off function is set when the system is on, the system will stop running when the setting time is reached.

Timer modification: when the system is under timer state, start or stop of the unit can be set via remote ON/OFF button and the timer can be reset. The system runs according to the latest setting state.

When both the timer on and timer off are set: the system runs according to the current setting state. When the setting time is reached, the unit will start and stop running. In that case, the unit will run according to the previously setting mode when the setting time for timer on is reached. The unit will stop running while the setting time for timer off is reached.

If the setting time for timer on and timer off is the same, the unit will stop running no matter what the current state is.

**(10)Auto-restart Function**

Memory: mode, up and down swing, light, setting temperature, setting fan speed, general timer (not clock), Fahrenheit / Celsius. After de-energized, the unit can run according to the memory if it is energized again. If the timer function is not set in the last remote control, the system will run according to the last remote control. If the timer function is set in the last control before it is de-energized, the system will memorize the last timer setting. The setting time is recalculated since the energization of the unit. If the timer function is set in the last control and the setting time is reached before the unit is de-energized, the unit will run according to the previous running mode after it is energized again. But the timer function will terminate. The clock will not be memorized.

In cooling and heating mode (not available in auto, dehumidify, fan mode), press the Turbo button, the fan speed displayed super high speed in the remote controller and the indoor fan rotates at super high speed.

**(11) Turbo function**

In cooling and heating mode (not available in auto, dehumidify, fan mode), press the Turbo button, the fan speed displayed super high speed in the remote controller and the indoor fan rotates at super high speed.

**(12) Health function**

When the indoor fan motor is running, the Health function is set by pressing remote controller (If there is no Health button on the remote controller, the Health function opening is defaulted).

**(13) I Feel function**

If the remote controller receives the I Feel order, the controller will work at the ambient temperature value which is sent by remote controller (Except the defrosting and anti-cool wind, which still adopts the sampling value of AC itself ambient temperature sensor), the remote controller will send ambient temperature value to controller every 10mins. After 11mins, if the controller hasn't received the ambient temperature value from the remote controller for long time, then it will run according to the current ambient temperature of AC. If the function has not been set, the ambient temperature will adopt the sensor sampling value of AC itself. If power off happens, this function will not be memorized.

● Temperature sensor malfunction detection

(1) Indoor temperature sensor

Detect malfunctions of temperature sensor any time.

(2) Indoor pipe temperature sensor

In defrosting period, the temperature sensor malfunction will not be detected. 5 min after finishing defrosting, the system begins to detect the temperature sensor malfunction. In other times, the temperature sensor malfunction will be detected.

(3) Protection of temperature sensor

1. When short-circuit occurs to the temperature sensor for 30s:

The temperature sensor overheats. In this case, the complete unit will stop for protection. At the same time, the temperature protection and temperature sensor malfunction will be shown.

2. When break-circuit occurs to the temperature sensor for 30s:

The unit will stop and the temperature sensor malfunction will be displayed

● Frequency Control

Frequency Initial Setting

<Outline>

When starting the compressor, or when conditions are varied due to the change of the room, the frequency must be initialized according to the  $\Delta D$  value of the indoor unit and the Q value of the indoor unit.

Q value: Indoor unit output determined from indoor unit volume, air flow rate and other factors.

PI Control (Determine Frequency Up / Down by  $\Delta D$  Signal)

1. P control

Calculate  $\Delta D$  value in each sampling time (20 seconds), and adjust the frequency according to its difference from the frequency previously calculated.

2. I control

If the operating frequency is not change more than a certain fixed time, adjust the frequency up and down according to the  $\Delta D$  value, obtaining the fixed  $\Delta D$  value.

When the  $\Delta D$  value is small...lower the frequency.

When the  $\Delta D$  value is large...increase the frequency.

3. Frequency management when other controls are functioning

When frequency is drooping;

Frequency management is carried out only when the frequency droops.

For limiting lower limit

Frequency management is carried out only when the frequency rises.

4. Upper and lower limit of frequency by PI control

The frequency upper and lower limits are set depending on indoor unit.

When low noise commands come from the indoor unit or when outdoor unit low noise or quiet commands come from indoor unit, the upper limit frequency must be lowered than the usual setting.

● 3-minutes Standby

Prohibit to turn ON the compressor for 3 minutes after turning it off.(except when defrosting)

● Compressor Protection Function

When turning the compressor from OFF to ON, the upper limit of frequency must be set as follows. (The function must not be used when defrosting.)

FCG 3	88
FCG 2	64
FCG 1	48
TCG1	240
TCG2	360
TCG3	180

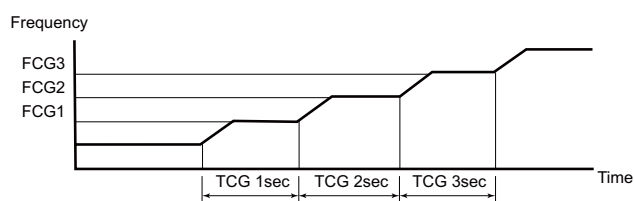

## ● Discharge Pipe Control

### Outline

The discharge pipe temperature is used as the compressor's internal temperature. If the discharge pipe temperature rises above a certain level, the operating frequency upper limit is set to keep this temperature from going up further.

### Detail

#### Divide the Zone

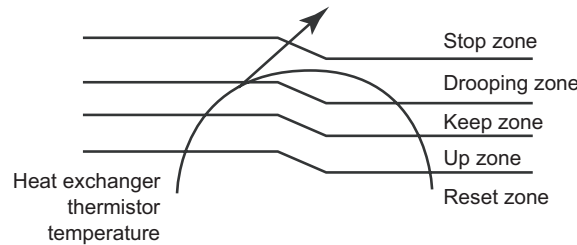

#### Management within the Zones

zone	control contents
Stop zone	When the temperature reaches the stop zone, stop the compressor and correct abnormality.
Drooping zone	Start the timer, and the frequency will be drooping.
Keep zone	Keep the upper limit of frequency.
Return / Reset zone	Cancel the upper limit of frequency.

## ● Input Current Control

### Outline

Detect an input current by the CT during the compressor is running, and set the frequency upper limit from such input current.

In case of heat pump model, this control is the upper limit control function of the frequency which takes priority of the lower limit of four way valve activating compensation.

### Detail

The frequency control will be made within the following zones.

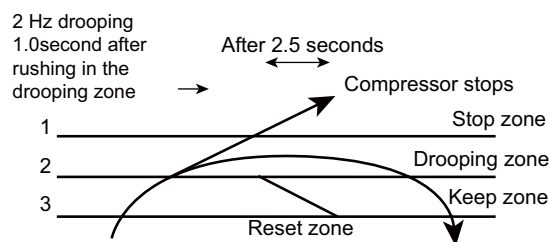

When a "stop current" continues for 2.5 seconds after rushing on the stop zone, the compressor operation stops.

If a "drooping current" is continues for 1.0 second after rushing on the drooping zone, the frequency will be 2 Hz drooping.

Repeating the above drooping continues until the current rushes on the drooping zone without change.

In the keep zone, the frequency limit will remain.

In the return / reset zone, the frequency limit will be cancelled.

#### Limitation of current drooping and stop value according to the outdoor air temperature

1. In case the operation mode is cooling

\* The current droops when outdoor air temperature becomes higher than a certain level (model by model).

2. In case the operation mode is heating

\* The current droops when outdoor air temperature becomes higher than a certain level (model by model).

## ● Freeze-up Protection Control

### Outline

During cooling operation, the signals being sent from the indoor unit allow the operating frequency limitation and then prevent freezing of the indoor heat exchanger. (The signal from the indoor unit must be divided into the zones as the followings.)

**Detail**

**Conditions for Start Controlling**

Judge the controlling start with the indoor heat exchanger temperature after 2 sec from operation start.

**Control in Each Zone**

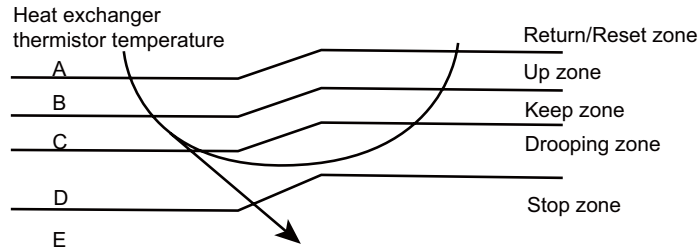

● **Heating Peak-cut Control**

**Outline**

**Heat Pump Only**

During heating operation, the signals being sent from the indoor unit allow the operating frequency limitation and prevent abnormal high pressure. (The signal from the indoor unit must be divided as follows.)

**Detail**

**Conditions for Start Controlling**

Judge the controlling start with the indoor heat exchanger temperature after 2 sec. from operation start.

**Control in Each Zone**

The heat exchange intermediate temperature of indoor unit controls the following.

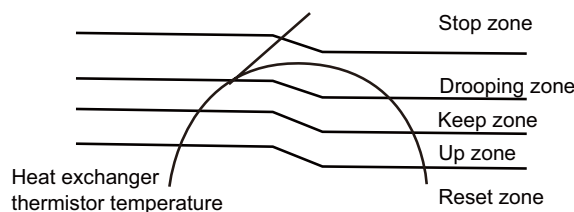

● **Defrost Control**

**Outline**

**Heat Pump Only**

Defrosting is carried out by the cooling cycle (reverse cycle). The defrosting time or outdoor heat exchanger temperature must be more than its fixed value when finishing.

**Detail**

**Conditions for Starting Defrost**

The starting conditions must be made with the outdoor air temperature and heat exchanger temperature. Under the conditions that the system is in heating operation, 6 minutes after the compressor is started and more than 44 minutes of accumulated time pass since the start of the operation or ending the defrosting.

**Conditions for Canceling Defrost**

The judgment must be made with heat exchanger temperature. (4°C~22°C)



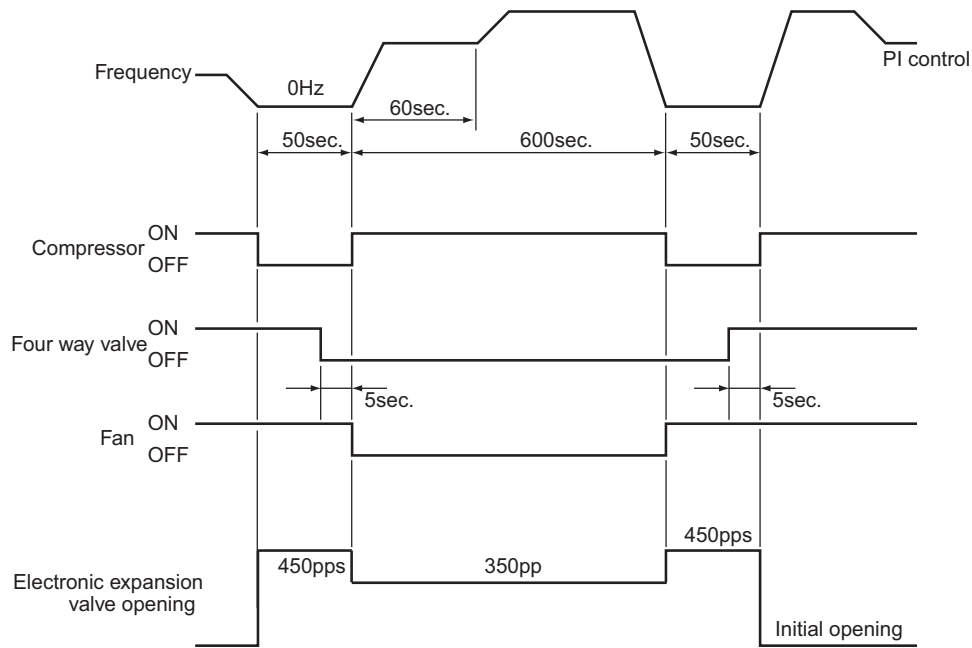

## ● Fan Control

### Outline

Fan control is carried out according to the following priority.

1. Fan ON control for electric component cooling fan
2. Fan control when defrosting
3. Fan OFF delay when stopped
4. ON/OFF control in cooling operation
5. Tap control when drooping function is working
6. Fan control in forced operation
7. Fan control in indoor/outdoor unit silent operation
8. Fan control in powerful mode
9. Fan control in normal operation

### Detail

#### Fan OFF Control when Stopped

\* Fan OFF delay for 60 seconds must be made when the compressor is stopped.

#### Tap Control in indoor/outdoor unit silent operation

1. When Cooling Operation

When the outdoor air temperature is lower than 37°C, the fan tap must be set to L.

2. When Heating Operation

When the outdoor air temperature is higher than 4°C, the fan tap must be turned to L (only for heat pump model).

## 7. Installation Manual



### Important Notices

1. **The unit installation work must be done by qualified personnel according to the local rules and this manual.**
2. **Before installing, please contact with local authorized maintenance center, if unit is not installed by the authorized maintenance center, the malfunction may not solved, due to discommodious contacts.**
3. **When removing the unit to the other place, please firstly contact with the authorized Maintenance Center in the local area.**

## Basic Requirements For Installation Position

Install in the following place may cause malfunction. If it is unavoidable contact with service center please:

- \* Place where strong heat sources, vapors, flammable gas or volatile object are emitted.
- \* Place where high-frequency waves are generated by radio equipment, welders and medical equipment.
- \* Place where a lot of salinities such as coast exists.
- \* Place where the oil (machine oil) is contained in the air.
- \* Place where a sulfured gas such as the hot spring zones is generated.
- \* Other place with special circumstance.

## 7.1 Tools Required for Installation (not supplied)

1. Gauge manifold
2. Electronic balance for refrigerant charging
3. Phillips head screwdriver
4. Knife or wire stripper
5. Carpenter's level
9. Hammer
10. Drill
11. Tube cutter
12. Tube flaring tool
13. Torque wrench
14. Adjustable wrench
15. Reamer (for deburring)
16. Vacuum pump (For R410A)
17. Gas leakage detector

## 7.2 Installation Position Selection

### 1. Indoor Unit

- (1) The air inlet and outlet vent should be far from the obstruction, make sure that the air can be blown through the whole room.
- (2) Select a position where the condensing water can be easily drained out, and the place is easily connected for outdoor unit.
- (3) Select a location where the children can not reach.
- (4) Can select the place where is strong enough to withstand the full weight and vibration of the unit. And will not increase the noise.
- (5) Be sure to leave enough space to allow access for routine maintenance. The height of the installed location should be 250cm or more from the floor.
- (6) Select a place about 1m or more away from TVset or any other electric appliances.
- (7) Select a place where the filter can be easily taken out.
- (8) Make sure that the indoor unit installation should accord with installation dimension diagram requirements.
- (9) Do not use the unit in the immediate surroundings of a laundry a bath a shower or a swimming pool.

### 2. Outdoor Unit

- (1) Select a location from which noise and outflow air emitted by unit will not inconvenience neighbors, animals, plants.
- (2) Select a location where there should be sufficient ventilation.
- (3) Select a location where there should be no obstructions cover the inlet and outlet vent.
- (4) The location should be able to withstand the full weight and vibration of the outdoor unit and permit safe installation.
- (5) Select a dry place, but do not expose under the direct sunlight or strong wind.
- (6) Make sure that the outdoor unit installation dimension should accord with installation dimension diagram, convenient for maintenance, repair.
- (7) The height difference of connecting the tubing within 5m, the length of connecting the tubing within 10m.
- (8) Select a place where it is out of reach for the children.
- (9) Select a place where will not block the passage and do not influence the city appearance.

## 7.3 Installation of Indoor Unit

### 1. Installing the mounting plate

The mounting plate should be installed on a wall which can support the weight of the indoor unit.

- 1) Temporarily secure the mounting plate to the wall, make sure that the panel is completely level, and mark the boring points on the wall.
- 2) Secure the mounting plate to the wall with screws.

Recommended mounting plate retention spots and dimensions

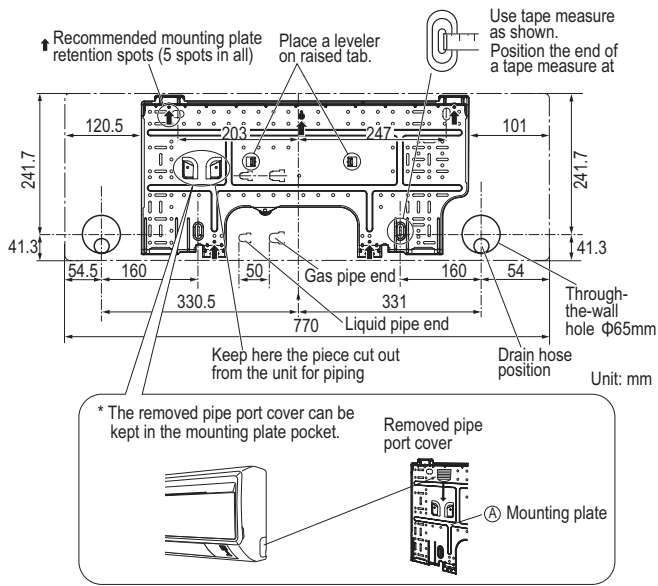

Burr removal

1. Completely remove all burrs from the cut cross section of pipe/tube.
2. Put the end of the copper tube/pipe in a downward direction as you remove burrs in order to avoid dropping burrs into the tubing.

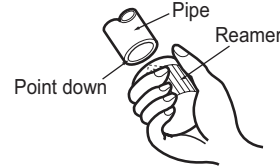

Putting nut on

Remove flare nuts attached to indoor and outdoor unit, then put them on pipe/tube having completed burr removal. (not possible to put them on after flaring work)

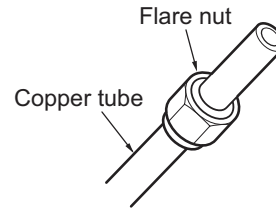

Flaring work

Firmly hold copper pipe in a die in the dimension shown in the table above.

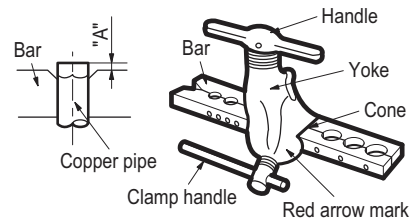

Carry out flaring work using flaring tool as shown below.

Outside diameter		A
mm	inch	mm
Ø6.35	1/4	0~0.5
Ø9.52	3/8	0~0.5
Ø12.7	1/2	0~0.5
Ø15.88	5/8	0~1.0
Ø19.05	3/4	1.0~1.3

Check

1. Compare the flared work with figure below.
2. If flare is noted to be defective, cut off the flared section and re-flare it.

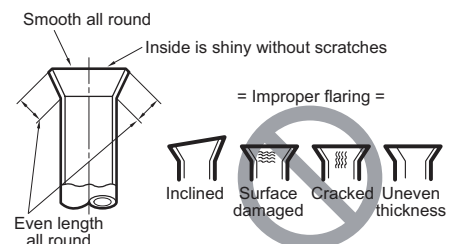
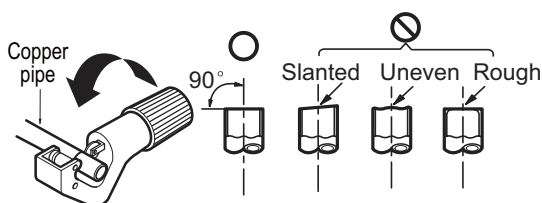

2. Boring Piping Hole

1. Make the piping hole (Ø65) in the wall at a slight downward slant to the outdoor side.
2. Insert the piping-hole sleeve into the hole to prevent the connection piping and wiring from being damaged when passing through the hole.

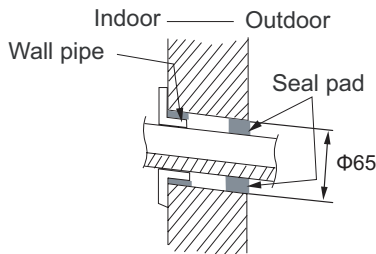

3. Flaring work and connection of piping

3.1 Flaring work

Flaring work

Main cause for refrigerant leakage is due to defect in the flaring work. Carry out correct flaring work using the following procedure.

Cut the pipes and the cable

1. Use the piping kit accessory or pipes purchased locally.
2. Measure the distance between the indoor and the outdoor unit.
3. Cut the pipes a little longer than the measured distance.
4. Cut the cable 1.5m longer than the pipe length.

### 3.2 Connection of piping

1. Align the center of the pipes and sufficiently tighten the flare nut by hand.

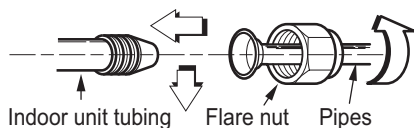

2. Tighten the flare nut with a wrench.

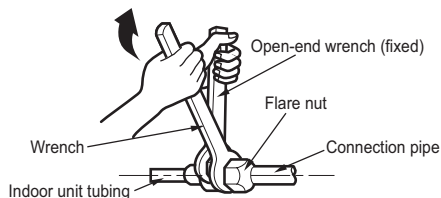

Outside diameter		Torque kg·m
mm	inch	
Ø6.35	1/4	1.8
Ø9.52	3/8	4.2
Ø12.7	1/2	5.5
Ø15.88	5/8	6.6
Ø19.05	3/4	6.6

### 4. Drain hose junction

If drain hose extension or embedded drain piping is required, use appropriate parts that match the hose front end. Insert drain hose into the handle of drain pan, and join drain hose and connecting hose according to the figure by.

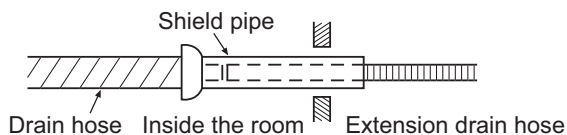

**CAUTION**

Insert the drain hose and drain cap into the drain port, making sure that it comes in contact with the back of the drain port, and then mount it. If the drain hose is not connected properly, leaking will occur.

- Attach the Insulation (Drain hose) to the drain hose.

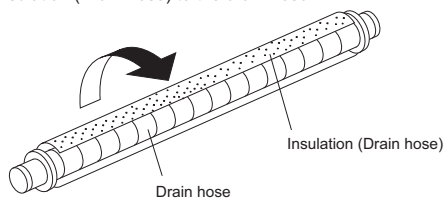

### 5. Wiring Connection

Wiring the connecting cable can be carried out without removing the front panel.

1. Remove the air inlet grille. Open the air inlet grille upward and pull it toward you.
2. Remove the terminal cover and cord clamp.
3. Insert the connecting cable (or as according to local regulations/codes) into the pipe hole on the wall.
4. Pull the connecting cable through the cable slot on the rear panel so that it protrudes about 15 cm out of the front.

5. Insert the connecting cable fully into the terminal block and secure it tightly with screws.
6. Tightening torque: 1.2 N·m (0.12 kgf·m).
7. Secure the connecting cable with the cord clamp.
8. Attach the terminal cover, rear plate bushing and air inlet grille on the indoor unit.

**CAUTION**

- Be sure to refer to the wiring system diagram labeled inside the front panel.
- Check local electrical regulations for any specific wiring instructions or limitations.

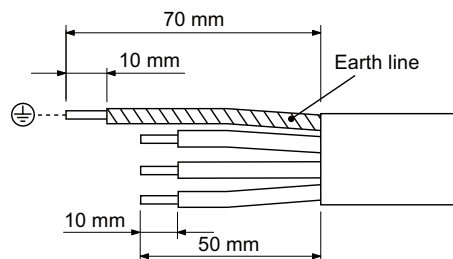
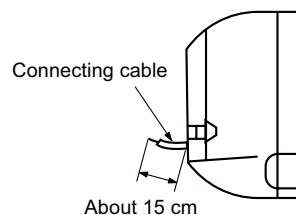
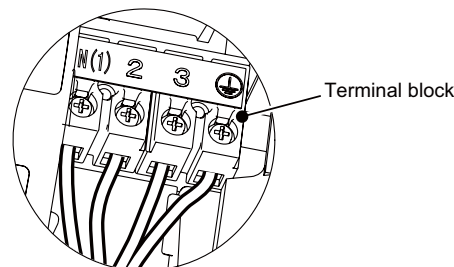
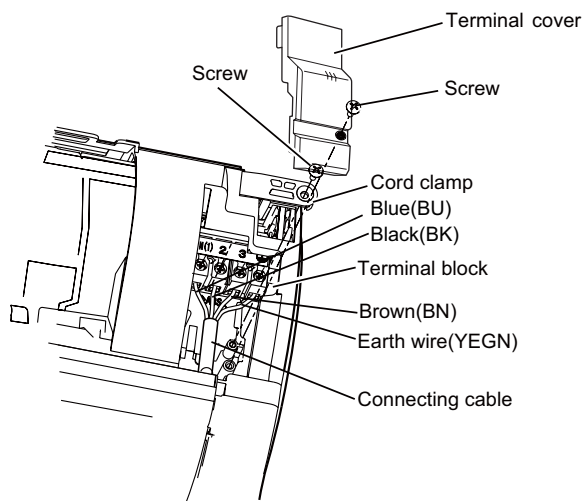

### 5. Installing indoor unit

In the case of bending or curing refrigerant pipes, keep the following precautions in mind.

Abnormal sound may be generated if improper work is conducted.

- 1) Do not strongly press the refrigerant pipes onto the bottom frame.
- 2) Do not strongly press the refrigerant pipes on the front grille, either.

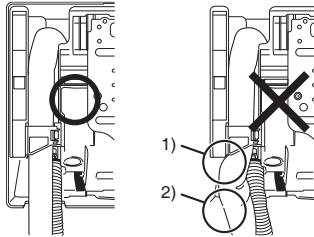

The piping can be lead out from right, right rear, left left rear.

#### Right-side, right-back, or right-bottom piping

- 1) After making slits on the front panel with a knife or similar tool, cut them out with a pair of nippers or an equivalent tool. Attach the drain hose to the underside of the refrigerant pipes with an adhesive vinyl tape.
- 2) Wrap the refrigerant pipes and drain hose together with an insulation tape.

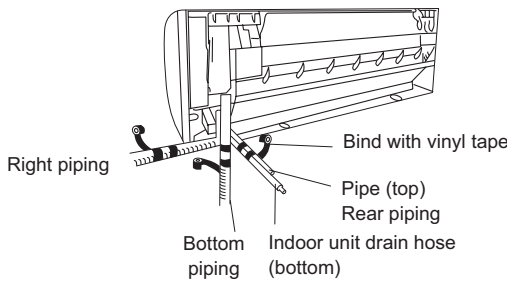

#### Left-side, left-back, or left-bottom piping

- Interchange the drain cap and the drain hose.

**CAUTION**

- (1) In order to align the drain hose and drain cap, be sure to insert securely and vertically. Incline insertion will cause water leakage.
- (2) When inserting, be sure not to attach any material besides water. If any other material is attached, it will cause deterioration and water leakage.
- (3) After removing drain hose, be sure not to forget mounting drain cap.
- (4) Be sure to fix the drain hose with tape to the bottom of piping.
- (5) Prevent drain water frozen under low temperature environment.  
When installing indoor unit's drain hose outdoors, necessary measure for frost protection should be taken to prevent drain water frozen.
  - Under low temperature environment (when outdoor temperature under 4 °C), after cooling operation is executed, water in the drain hose could be frozen. Once drain water is frozen, the drain hose will be blocked and water leakage may be resulted for indoor unit.

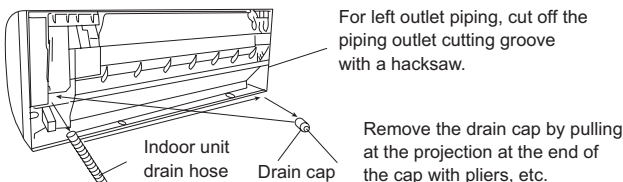

#### How to replace the drain plug and drain hose

- **How to remove the drain cap**  
Clamp drain cap with needle-nose pliers, and pull out.
- **How to remove the drain hose**  
The drain hose is secured in place by a screw. Remove the screw securing the drain hose, then pull out the drain hose.
- **How to attach the drain cap**
  1. Insert hexagonal wrench (4 mm).
  2. Firmly insert drain cap.
- **How to attach the drain hose**  
Insert the drain hose firmly until the connector contacts the insulation, then secure it in place using the original screw.

1. After making slits on the front panel with a knife or similar tool, cut them out with a pair of nippers or an equivalent tool.

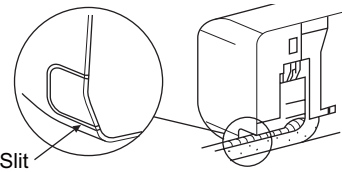

2. Overlap the connection pipe insulation material and the indoor unit pipe insulation material. Bind them together with vinyl tape so that there is no gap.

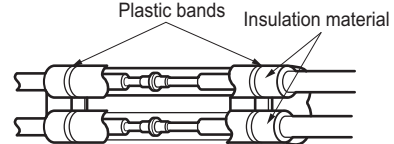

3. Wrap the area which accommodates the rear piping housing section with vinyl tape.

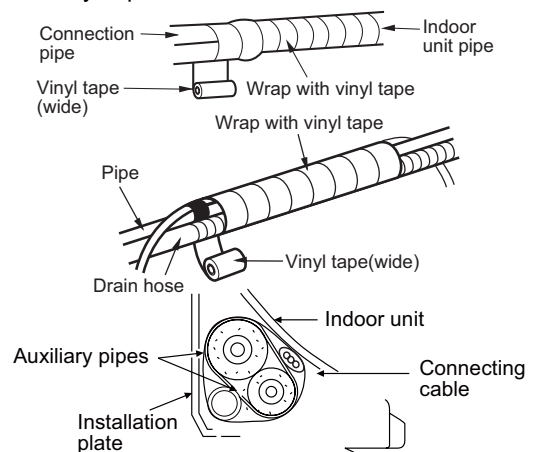

4. Bundle the piping and drain hose together by wrapping them with vinyl tape for enough to cover where they fit into the rear piping housing section.

#### Indoor unit installation

- 1) Pass the drain hose and refrigerant pipes through the wall hole, then set the indoor unit on the mounting plate hooks by using the markings at the top of the indoor unit as a guide.

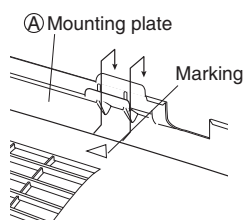

2) Swing the indoor unit to right and left to confirm that it is firmly hooked on the installation plate.

3) While pressing the indoor unit onto the wall, hook it at the lower part on the installation plate.

Pull the indoor unit toward you to confirm that it is firmly hooked on the installation plate.

For detaching the indoor unit from the installation plate pull the indoor unit toward you while pushing the bottom up at the specified places.

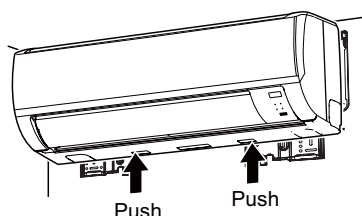

4) Run the drain hose at a downward sloped angle.

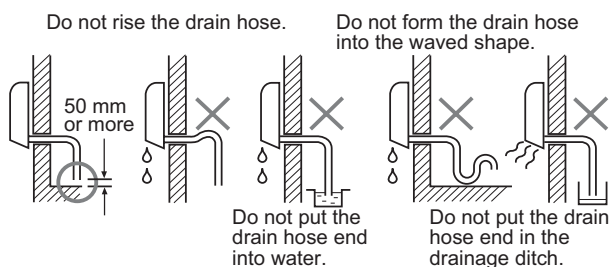

5) Put water in the drain pan and make sure that the water is being drained outside.

**Caution:**

Install the drain pipe for proper drainage. Improper drainage can result in water dripping inside the room.

## 7.4 Installation of Outdoor Unit

### 4.1 Draining the Water

\* Holes are provided on the base plate of the outdoor unit to ensure that the defrost water produced during heating operations is drained off efficiently.

\* If a centralized drain is required when installing the unit on a balcony or wall.

\* If the drain port is covered by a mounting base or floor surface, place additional foot bases of at least 30mm in height under the outdoor unit's feet.

\* In cold areas, do not use a drain hose with the outdoor unit. (Otherwise, drain water may freeze, impairing heating performance.)

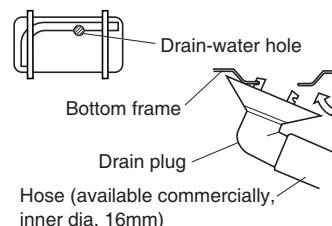

### 4.2 Refrigerant Piping Connection

Remove the Valve cover from the unit by loosening the screw. Align the center of the pipings and sufficiently tighten the flare nut by hand.

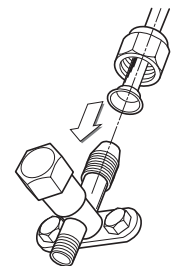

Finally, tighten the flare nut with torque wrench until the wrench clicks.

#### Outdoor unit

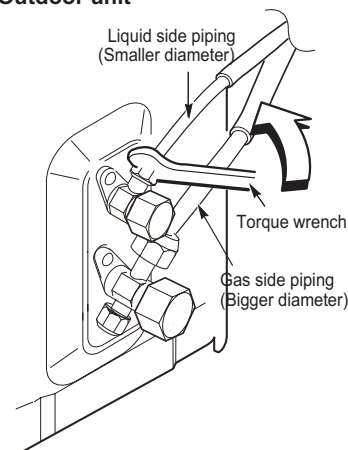

### 4.3 Evacuation

After the piping has been connected to the indoor unit, perform the air purge.

#### AIR PURGE

**Evacuate the air in the connecting pipes and in the indoor unit using a vacuum pump.**

**Do not use the refrigerant in the outdoor unit.**

**For details, see the vacuum pump manual.**

Air purging with vacuum pump

Be sure to use a vacuum pump with counter-flow prevention function so that oil inside the pump does not flow back into the air conditioner pipes when the pump stops. (If oil inside the vacuum pump enters into the air conditioner circuit which uses R410A, trouble with the refrigeration system may develop.)



1. Connect the charge hose from the manifold valve to the service port of the gas side packed valve.
2. Connect the charge hose to the port of the vacuum pump.
3. Open fully the low pressure side handle of the gauge manifold valve.
4. Operate the vacuum pump to begin evacuating. Perform evacuating for about 15 minutes if the piping length is 20 meters (15 minutes for 20 meters) (assuming a pump capacity of 27 liters per minute). Confirm that the compound pressure gauge reading is  $-101\text{ kPa}$  ( $-76\text{ cmHg}$ ).
5. Close the low pressure valve handle of gauge manifold.
6. Open fully the valve stem of the packed valves (both sides of Gas and Liquid).
7. Remove the charging hose from the service port.
8. Securely tighten the caps on the packed valves.

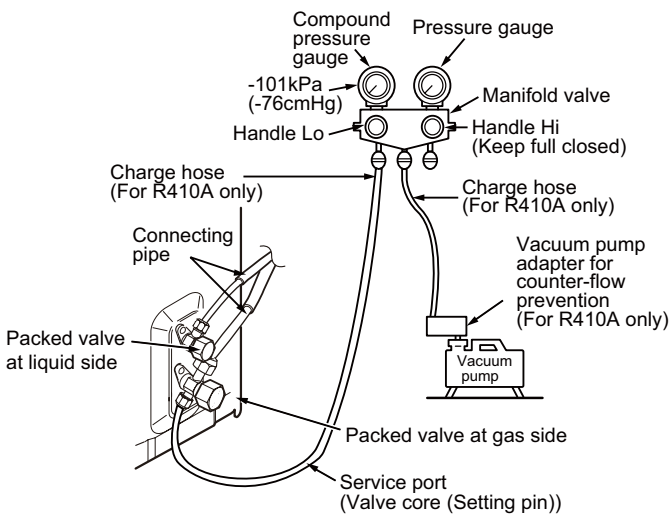

**CAUTION**

**• IMPORTANT POINTS FOR PIPING WORK**

1. Keep dust and moisture from entering the pipes.
2. Tighten connections carefully (between pipes and unit).
3. Evacuate the air in the connecting pipes using a VACUUM PUMP.
4. Check for gas leaks at all connections.

**Packed Valve handling precautions**

- Open the valve stem all the way; but do not try to open it beyond the stopper.
- Securely tighten the valve stem cap with torque in the following table:

Gas side (Ø9.52 mm)	33 to 42 N•m (3.3 to 4.2 kgf•m)
Liquid side (Ø6.35 mm)	14 to 18 N•m (1.4 to 1.8 kgf•m)
Service port	14 to 18 N•m (1.4 to 1.8 kgf•m)

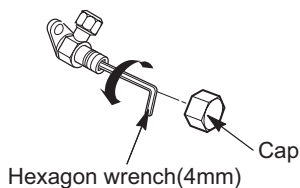

**4.4 Wiring Connection**

- 1) Strip the insulation from the wire (20mm).
  - 2) Connect the connection wires between the indoor and outdoor units so that the terminal numbers match. Tighten the terminal screws securely.
- The screws are packed with the terminal board.

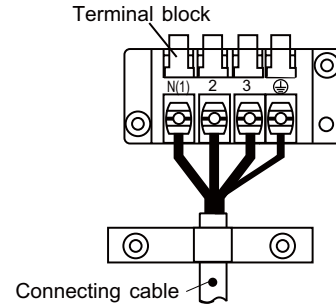

**7.5 Test Operation**

1. Check that all tubing and wiring have been properly connected.
2. Check that the gas and liquid side service valves are fully open.

**5.1 Gas Leak Test**

Check the flare nut connections for gas leaks with a gas leak detector and/or soapy water.

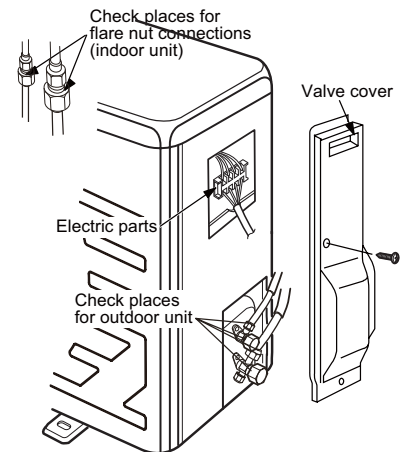

**5.2 Test Running**

- 1) Switch on power, press "ON/OFF" button on the wireless remote control to start the operation.
- 2) Press MODE button, to select the COOL, HEAT (Cooling only unit is not available), FAN to check whether the operation is normal or not.

Perform test operation and check items 1 and 2 below.

**1. INDOOR UNIT**

- (1) Is operation of each button on the remote control unit normal?
- (2) Does each lamp light normally?
- (3) Do the air flow-direction louver operate normally?
- (4) Is the drain normal?

**2. OUTDOOR UNIT**

- (1) Is there any abnormal noise and vibration during operation?
- (2) Will noise, wind, or drain water from the unit disturb the neighbors?
- (3) Is there any gas leakage?

## 9. Troubleshooting

### 9.1 Precautions before Performing Inspection or Repair

Be cautious during installation and maintenance. Do operation following the regulations to avoid electric shock and casualty or even death due to drop from high attitude.

\* Static maintenance is the maintenance during de-energization of the air conditioner.

For static maintenance, make sure that the unit is de-energized and the plug is disconnected.

\*dynamic maintenance is the maintenance during energization of the unit.

Before dynamic maintenance, check the electricity and ensure that there is ground wire on the site. Check if there is electricity on the housing and connection copper pipe of the air conditioner with voltage tester. After ensure insulation place and the safety, the maintenance can be performed.

Take sufficient care to avoid directly touching any of the circuit parts without first turning off the power.

At times such as when the circuit board is to be replaced, place the circuit board assembly in a vertical position.

Normally,diagnose troubles according to the trouble diagnosis procedure as described below.(Refer to the check points in servicing written on the wiring diagrams attached to the indoor/outdoor units.)

No.	Troubleshooting procedure
1	Confirmation
2	Judgement by Flashing LED of Indoor/Outdoor Unit
3	How to Check simply the main part

Precautions when inspecting the control section of the outdoor unit :

A large-capacity electrolytic capacitor is used in the outdoor unit controller (inverter).Therefore,if the power supply is turned off,charge(charging voltage DC280V to 380V)remains and discharging takes a lot of time. After turning off the power source,if touching the charging section before discharging, an electrical shock may be caused.

The outdoor unit can not be started up until the unit is de-energized for 20min

### 9.2 Confirmation

(1)Confirmation of Power Supply

Confirm that the power breaker operates(ON) normally;

(2)Confirmation of Power Voltage

Confirm that power voltage is AC 220–230–240 ± 10%.

If power voltage is not in this range, the unit may not operate normally.



### 9.3 Judgement by Flashing LED of Indoor/Outdoor Unit

code	malfunction	Error display		Repair method	code	malfunction	Error display		Repair method
		Dual 8 display	LED				Dual 8 display	LED	
1	Storage slug	EE	Heating LED-pause 3s and blink 15 times	Replace indoor main board	15	Sync failure	H7	Heating LED-pause 3s and blink 7 times	Check if the resistance of compressor and resistance to ground is normal. If the compressor is normal, the outdoor main board may be wrong.
2	Indoor PCB malfunction	EE	Heating LED-pause 3s and blink 15 times	Replace indoor main board	16	Current detection malfunction of complete unit	U5	Cooling LED-pause 3s and blink 13 times	Replace outdoor main board
3	Anti-freezing protection	E2	Running LED-pause 3s and blink 2 times	Outdoor ambient temperature is too low	17	Outdoor ambient temperature sensor malfunction	F3	Cooling LED-pause 3s and blink 3 times	Is it loose? Measure the resistance value with universal meter
4	Overload of system	H4	Heating LED-pause 3s and blink 4 times	System is abnormal, check if the evaporator and condenser is dirty and blocked	18	Discharge protection of compressor	E4	Running LED-pause 3s and blink 4 times	Is it loose? Measure the resistance value with universal meter
5	No motor of indoor unit feedback	H6	Running LED-pause 3s and blink 11 times	Is electromotor mounted normally?	19	Break-circuit and short-circuit of outdoor discharge temperature sensor	F5	cooling LED-pause 3s and blink 5 times	Is it loose? Measure the resistance value with universal meter
6	Indoor pipe temperature sensor malfunction	F2	cooling LED-pause 3s and blink 2 times	Is it loose? Measure the resistance value with universal meter	20	Break-circuit and short-circuit of outdoor condenser temperature sensor	F4	cooling LED-pause 3s and blink 18 times	Is it loose? Measure the resistance value with universal meter
7	Internal ambient temperature sensor malfunction	F1	Cooling LED-pause 3s and blink 1 times	Is it loose? Measure the resistance value with universal meter	21	Overheat of carbon fin	P8	heating LED-pause 3s and blink 19 times	Is outdoor ambient temperature is too high? Is radiator mounted correctly?
8	Zero passage abnormal	UF	Heating and cooling LED blinks 7 times at the same time	Replace indoor main board	22	DC overcurrent	UU	Heating and cooling LED blink 11 times at the same time	
9	Overload of compressor	H3	heating LED-pause 3s and blink 3 times	Inspect connection state of the overload wire.	23	Temperature sensor malfunction of carbon fin	P7	heating LED-pause 3s and blink 18 times	Replace outdoor main board.
10	Startup failure	Lc	heating LED-pause 3s and blink 11 times	Check if the resistance of compressor and resistance to ground is normal. If the compressor is normal, the outdoor main board may be wrong.	24	Lack of Freon or block protection	F0	cooling LED-pause 3s and blink 10 times	
11	No motor of outdoor unit feedback	UH	Heating and cooling LED blink 8 times at the same time	This malfunction may happen when outdoor DC electromotor is used.	25	DC input voltage is too high	PH	cooling LED-pause 3s and blink 11 times	Is voltage of AC power supply normal?
12	Overcurrent protection	E5	Running LED-pause 3s and blink 5 times	Is electric network variable?	26	DC input voltage is too low	PL	Heating LED-pause 3s and blink 21 times	Is voltage of AC power supply normal?
13	4-way valve conversion abnormal	U7	cooling LED-pause 3s and blink 20 times	Replace 4-way valve.	27	Communication malfunction	E6	Running LED-pause 3s and blink 6 times	Is outdoor connecting wire reliably connected?
14	Phase current detection malfunction of compressor	U1	Heating LED-pause 3s and blink 13 times	Replace outdoor main board.	28	Setting error, indoor and outdoor unit abnormal	UA	Heating and cooling LED blink 12 times at the same time	Outdoor unit is not matched with indoor unit.
remarks	4min after protection stop of compressor, the malfunction is shown in error code. In other situation, the malfunction will be displayed by press the light button for 6 times within 4s.								

## 9.4 How to Check simply the main part

### (1) Malfunction of power supply from indoor unit to outdoor unit

Main inspection point:

Inspect the power supply plug seat with AC voltage gauge to check if the voltage between L and N is within 200VAC~240VAC;  
 Check with AC voltage gauge if the voltage between N 1 and 3 of indoor wiring block is within 200VAC~240VAC;  
 Check with AC voltage gauge if the voltage between L and N of outdoor wiring block is within 200VAC~240VAC;

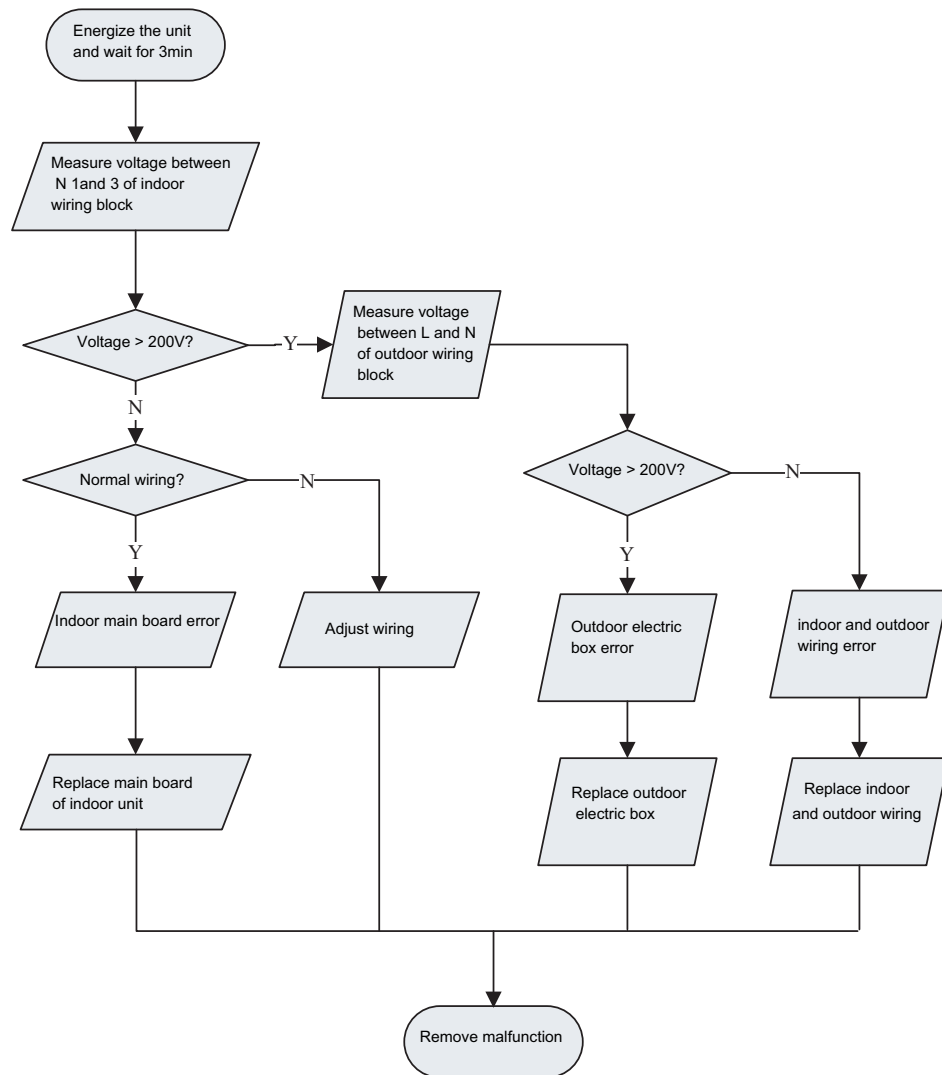

### (2) Indoor fan does not rotate without feedback

Main detection point:

- Is the control panel reliably connected with the electromotor? Is it loose? Is the connecting sequence correct?
- Is the input voltage within the normal range (measure the voltage between L and N of the wiring block XT with AC voltage gauge.)?

Malfunction diagnosis process:

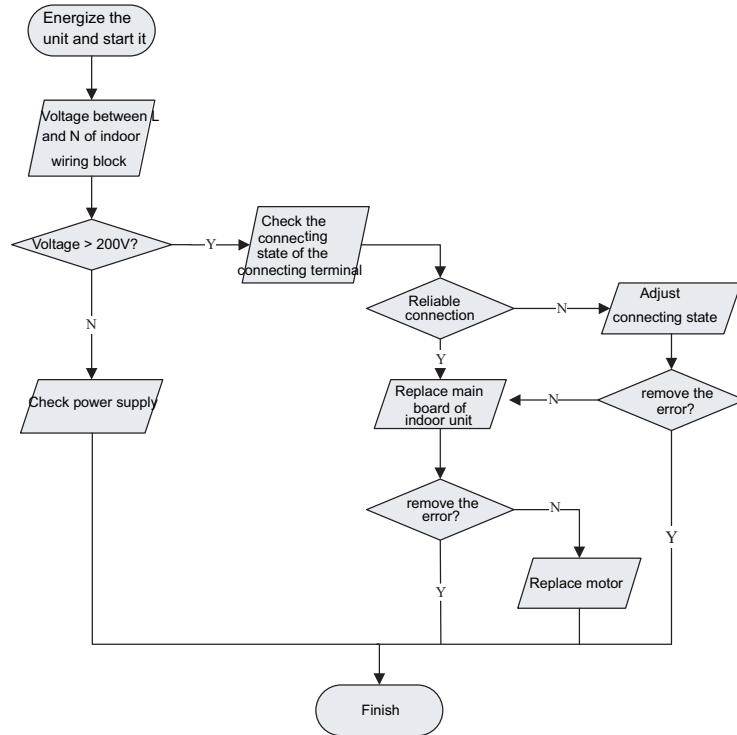

(3) Temperature sensor malfunction

Main detection point:

- Is outdoor ambient temperature within the normal range?
- Is indoor and outdoor fan running normally?
- Is the radiating environment inside and outside the unit good enough?

Malfunction diagnosis process:

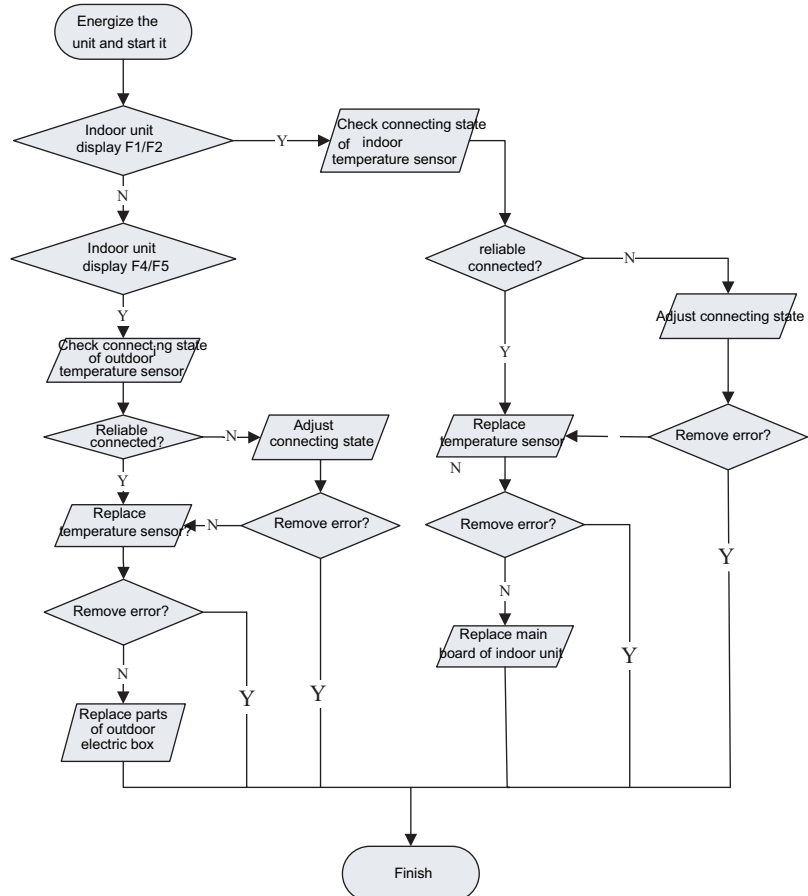

(4) Malfunction diagnosis of startup failure

Main detection points:

- Is wiring of compressor correct.
- Is the stop time of compressor enough?
- Is compressor damaged?

Malfunction diagnosis process:

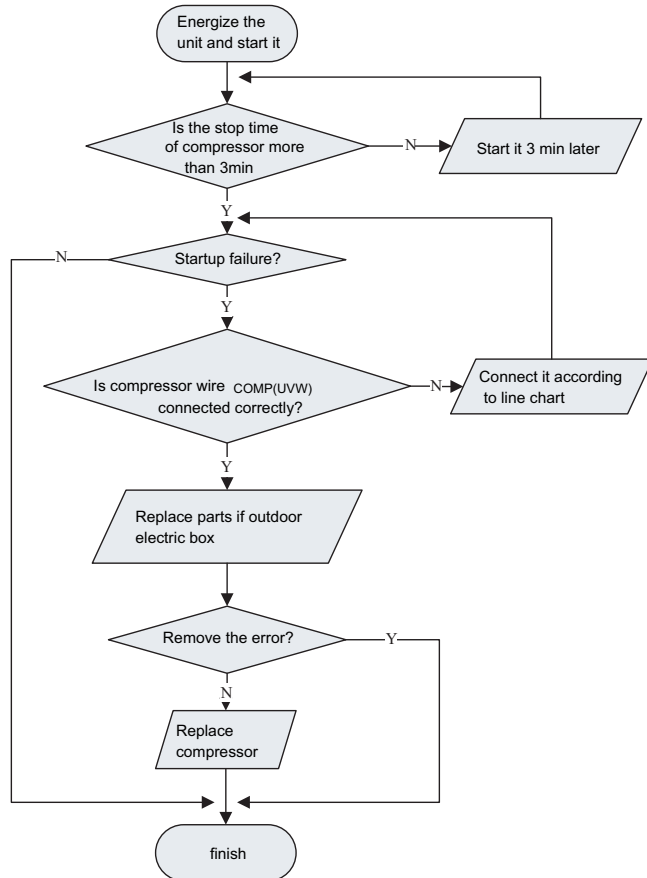

(5) Diagnosis of losing synchronism for compressor

Main detection points:

- Is pressure of the system too high?
- Is voltage too low?

Malfunction diagnosis process:

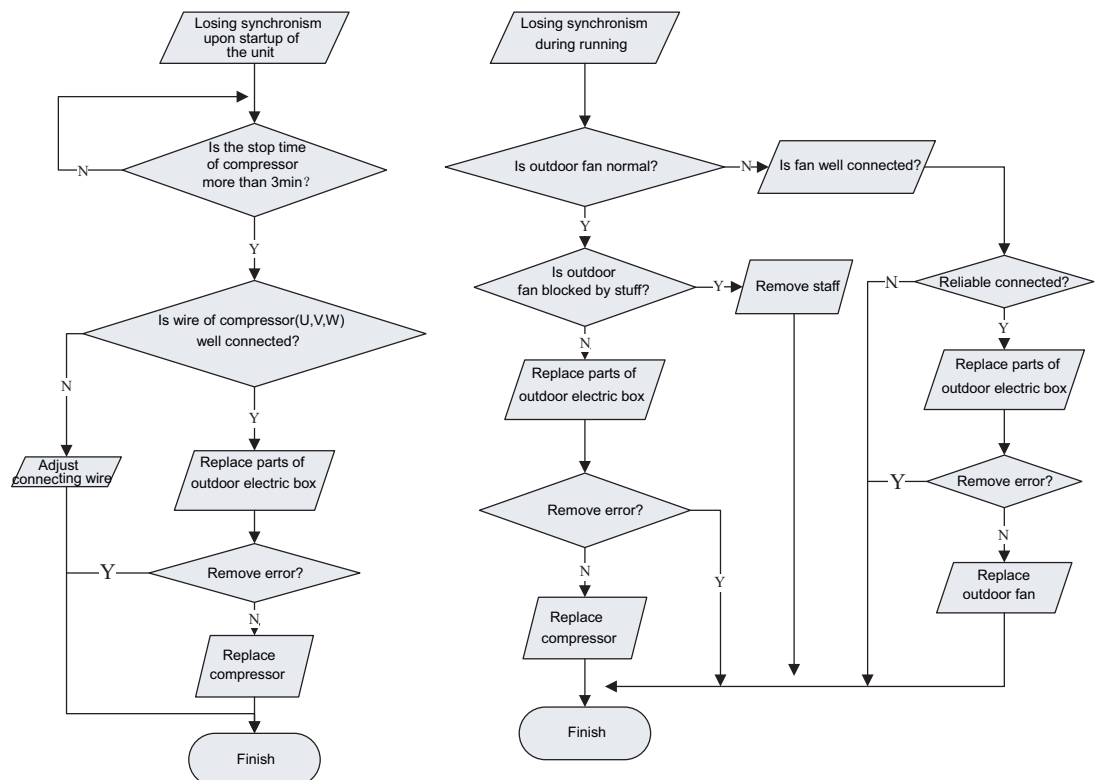

(6) Diagnosis of overload and discharge malfunction

Main detection points:

- Is electric expansion valve well connected? Is it damaged?
- Is refrigerant leaked?
- Is overload wire connection normal?

Malfunction diagnosis process:

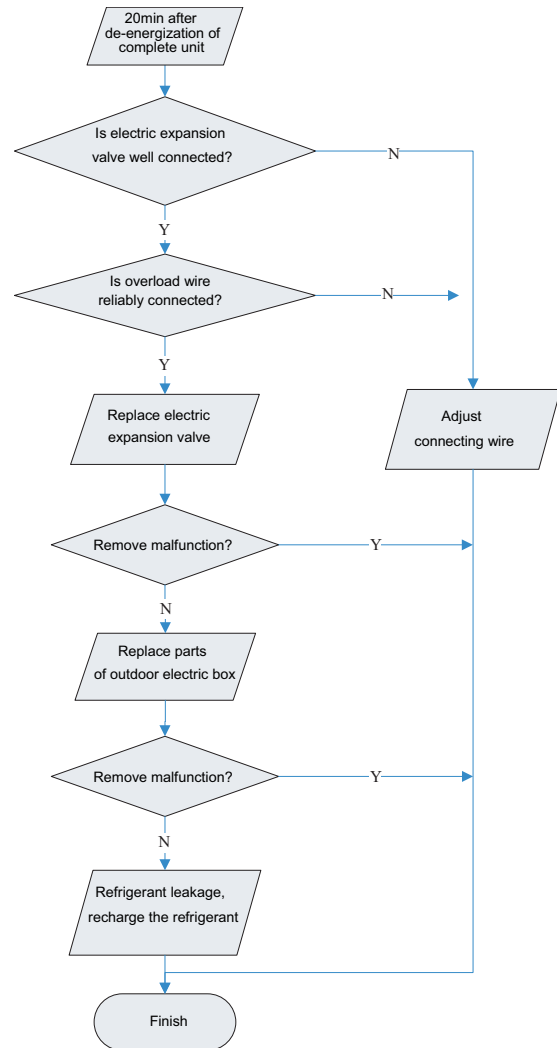

(7) Process of outdoor unit communication circuit detection

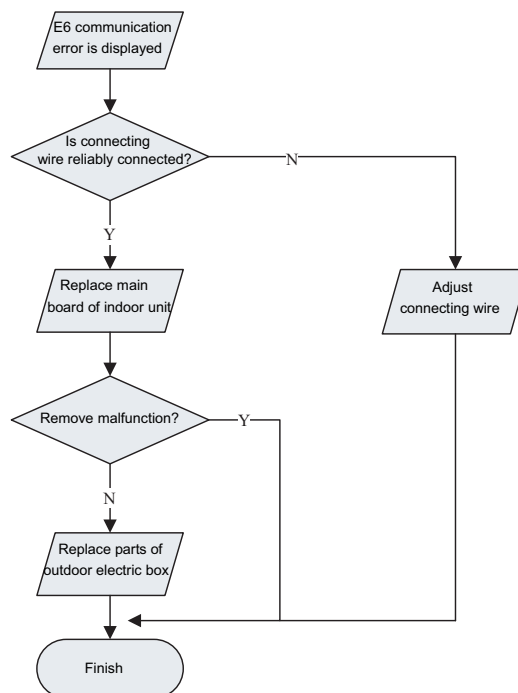

## 9.5 2-way, 3-way Valve Appearance

		2-way Valve (Liquid Side)	3-way Valve (Gas Side)	
Works		Shaft position	Shaft position	Service port
Shipping		Closed (with valve cap)	Closed (with valve cap)	Closed (with cap)
1.	Air purging (Installation)	Closed (clockwise)	Closed (clockwise)	Open (with vacuum pump)
Operation		Open (with valve cap)	Open (with valve cap)	Closed (with cap)
2.	Pumping down (Transferring)	Closed (clockwise)	Open (counter-clockwise)	Open (connected manifold gauge)
3.	Evacuation (Servicing)	Open	Open	Open (with charging cylinder)
4.	Gas charging (Servicing)	Open	Open	Open (with charging cylinder)
5.	Pressure check (Servicing)	Open	Open	Open (with charging cylinder)
6.	Gas releasing (Servicing)	Open	Open	Open (with charging cylinder)

**Air purging**

**CAUTION: Do not leak the gas in the air during Air purging.**

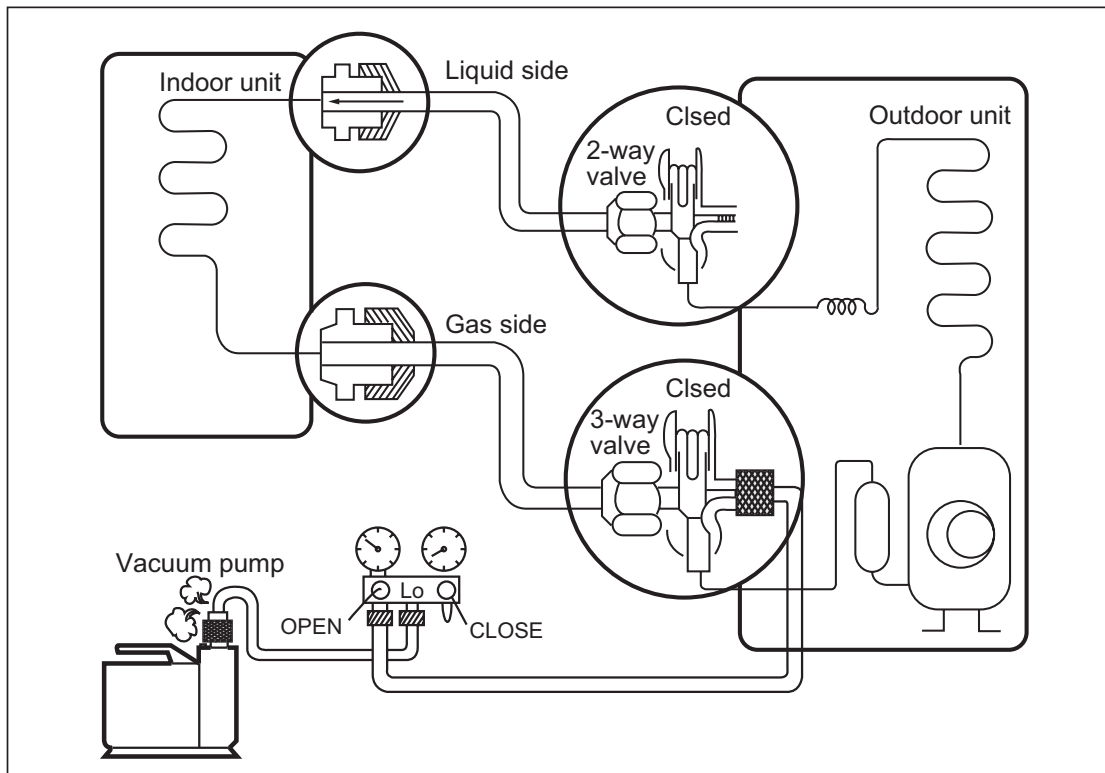

**\* Procedure**

- (1) Connect the charge hose from the manifold valve to the service port of the gas side packed valve.
- (2) Connect the charge hose to the port of the vacuum pump.
- (3) Open fully the low pressure side handle of the gauge manifold valve.
- (4) Operate the vacuum pump to begin evacuating. Perform evacuating for about 15 minutes if the piping length is 20 meters (15 minutes for 20 meters) (assuming a pump capacity of 27 liters per minute). Confirm that the compound pressure gauge reading is  $-101 \text{ kPa}$  ( $-76 \text{ cmHg}$ ).
- (5) Close the low pressure valve handle of gauge manifold.
  - Check the flare connections for gas leakage.
- (6) Use torque wrench to tighten the service port nut to a torque of  $1.8 \text{ kg.cm}$ .
- (7) Set the 3-way valve to the back seat.
- (8) Mount the valve stem nuts to the 2-way and 3-way valves.
- (9) Check for gas leakage.
  - At this time, especially check for gas leakage from the 2-way and 3-way valve's stem nuts, and from the service port nut.

**CAUTION:**

If gas leakage are discovered in step 5 above, take the following measures :

If the gas leaks stop when the piping connections are tightened further, continue working from step 6. If the gas leaks do not stop when the connections are retightened, repair the location of the leak, discharge all of the gas through the service port, and then recharge with the specified amount of gas from a gas cylinder.

**Pumping Down**

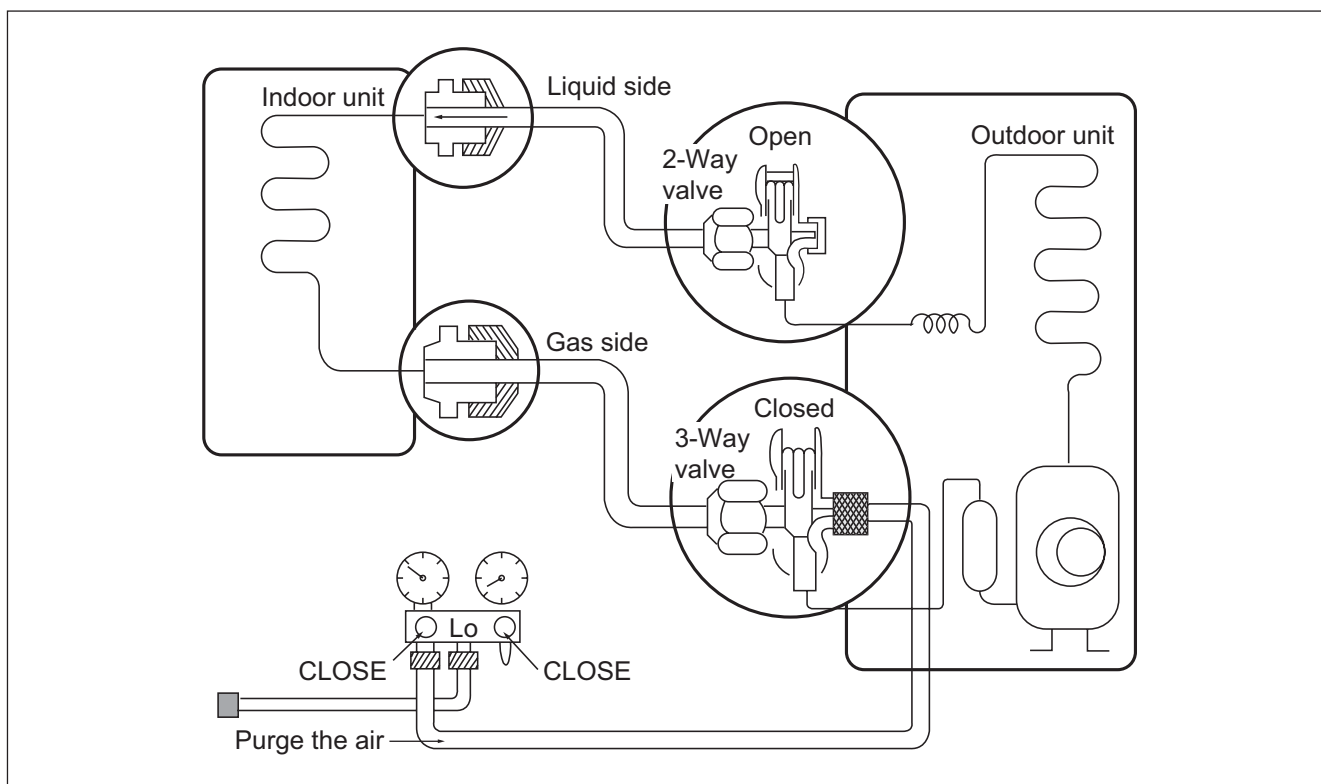

**• Procedure**

**(1) Confirm that both the 2-way and 3-way valves are set to the open position.**

- Remove the valve stem caps and confirm that the valve stems are in the raised position.
- Be sure to use a hexagonal wrench to operate the valve stems.

**(2) Operate the unit for 10 to 15 minutes.**

**(3) Stop operation and wait for 3 minutes, then connect the charge set to the service port of the 3-way valve.**

- Connect the charge hose with the push pin to the service port.

**(4) Air purging of the charge hose.**

- Open the low-pressure valve on the charge set slightly to air purge from the charge hose.

**(5) Set the 2-way valve to the closed position.**

**(6) Operate the air conditioner at the cooling cycle and stop it when the gauge indicates 1kg/cm<sup>2</sup>g.**

**(7) Immediately set the 3-way valve to the closed position.**

- Do this quickly so that the gauge ends up indicating 3 to 5kg/cm<sup>2</sup>g.

**(8) Disconnect the charge set, and mount the 2-way and 3-way valve's stem nuts and the service port nut.**

- Use torque wrench to tighten the service port nut to a torque of 1.8 kg.m.
- Be sure to check for gas leakage.



Re-air Purging

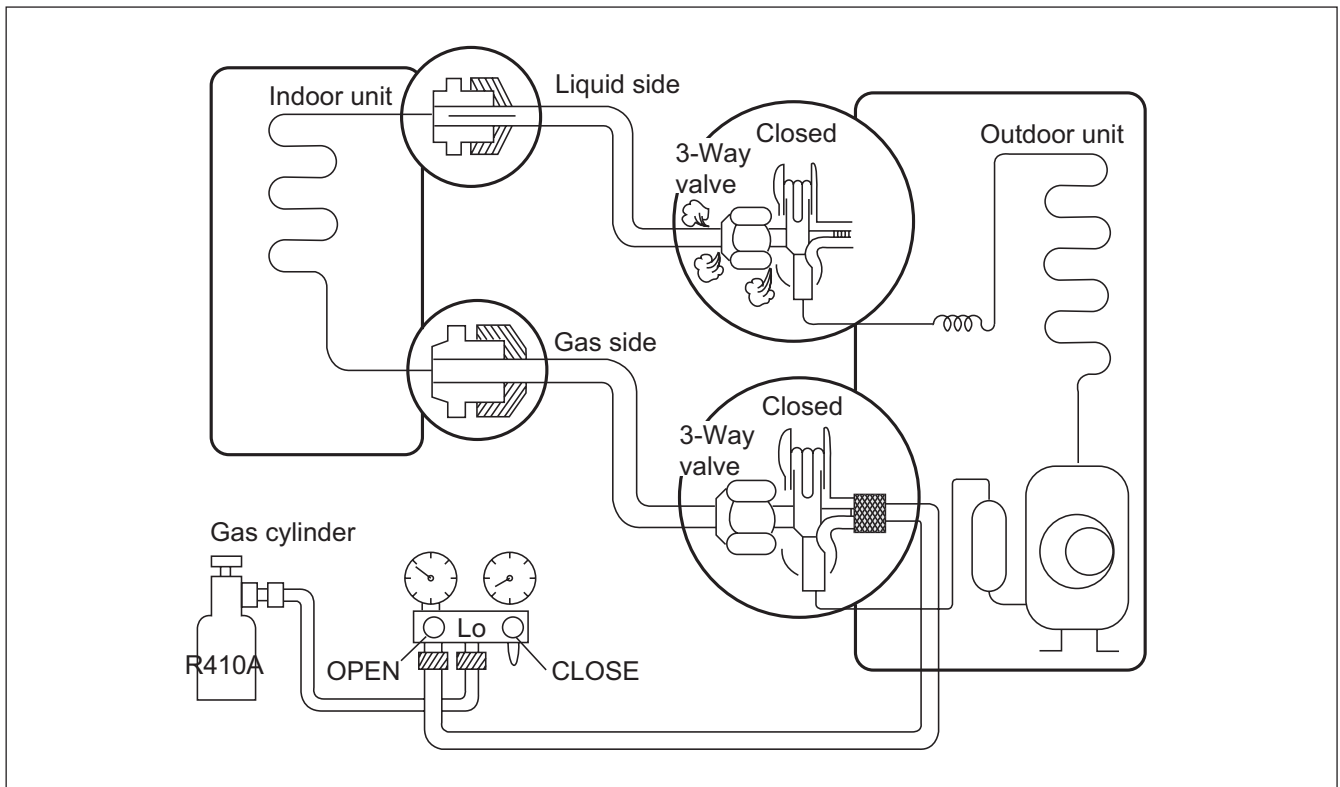

• Procedure

**(1) Confirm that both the liquid side valve and the gas side valve are set to the closed position.**

**(2) Connect the charge set and a gas cylinder to the service port of the Gas side valve.**

– Leave the valve on the gas cylinder closed.

**(3) Air purging.**

– Open the valves on the gas cylinder and the charge set. Purge the air by loosening the flare nut on the liquid side valve approximately 45° or 3 seconds then closing it for 1 minute; repeat 3 times.

– After purging the air, use a torque wrench to tighten the flare nut on liquid side valve.

**(4) Check for gas leakage.**

– Check the flare connections for gas leakage.

**(5) Discharge the refrigerant.**

– Close the valve on the gas cylinder and discharge the refrigerant until the gauge indicates 3 to 5 kg/cm<sup>2</sup>g.

**(6) Disconnect the charge set and the gas cylinder, and set the Liquid side and Gas side valves to the open position.**

– Be sure to use a hexagonal wrench to operate the valve stems.

**(8) Mount the valve stem nuts and the service port nut.**

– Use torque wrench to tighten the service port nut to a torque of 1.8 kg.m.

– Be sure to check for gas leakage.

**CAUTION: Do not leak the gas in the air during Air Purging.**

## Balance Refrigerant of the 3-way Valve

(Gas leakage)

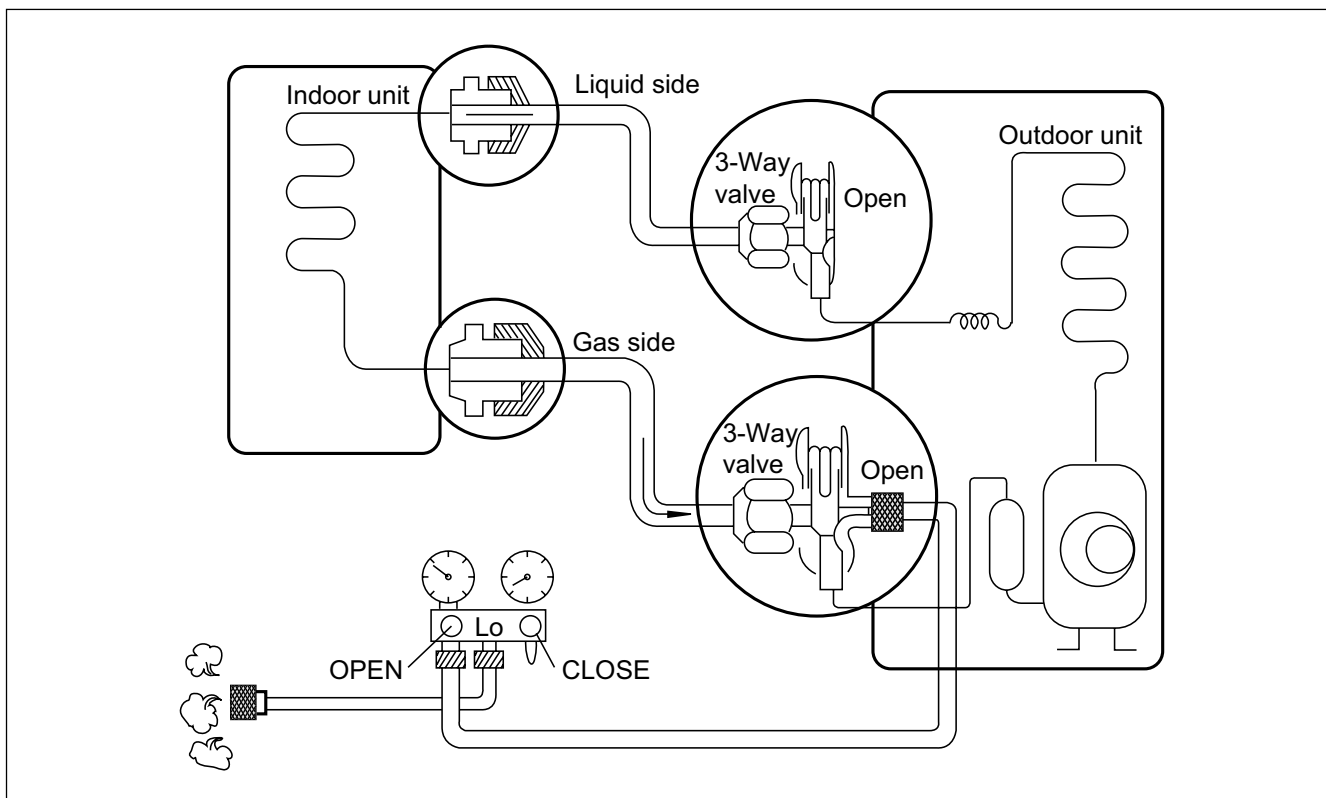

### • Procedure

- (1) Confirm that both the 2-way and 3-way valves are set to the back seat.
- (2) Connect the charge set to the 3-way valve's port.
  - Leave the valve on the charge set closed.
  - Connect the charge hose to the service port.
- (3) Open the valve (Lo side) on the charge set and discharge the refrigerant until the gauge indicates 0 kg/cm<sup>2</sup>G.
  - If there is no air in the refrigerant cycle (the pressure when the air conditioner is not running is higher than 1 kg/cm<sup>2</sup>G), discharge the refrigerant until the gauge indicates 0.5 to 1 kg/cm<sup>2</sup>G. If this is the case, it will not be necessary to apply a evacuation.
  - Discharge the refrigerant gradually; if it is discharged too suddenly, the refrigeration oil will also be discharged.

## Evacuation

(All amount of refrigerant leaked)

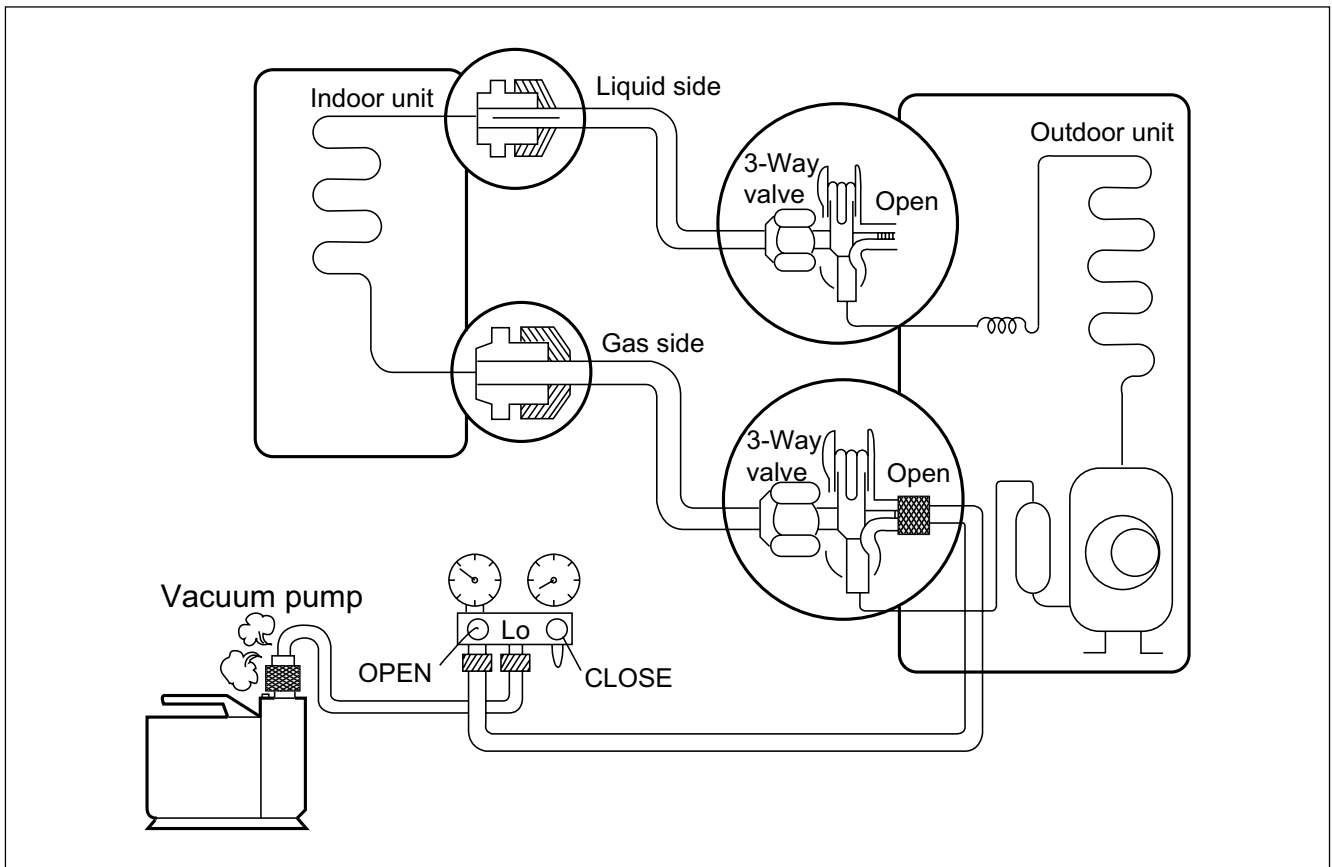

### • Procedure

- (1) Connect the vacuum pump to the center hose of charge set center hose
- (2) Evacuation for approximately one hour.
  - Confirm that the gauge needle has moved toward -76 cmHg (vacuum of 4 mmHg or less).
- (3) Close the valve (Lo side) on the charge set, turn off the vacuum pump, and confirm that the gauge needle does not move (approximately 5 minutes after turning off the vacuum pump).
- (4) Disconnect the charge hose from the vacuum pump.
  - Vacuum pump oil.  
If the vacuum pump oil becomes dirty or depleted, replenish as needed.

## Gas Charging

(After Evacuation)

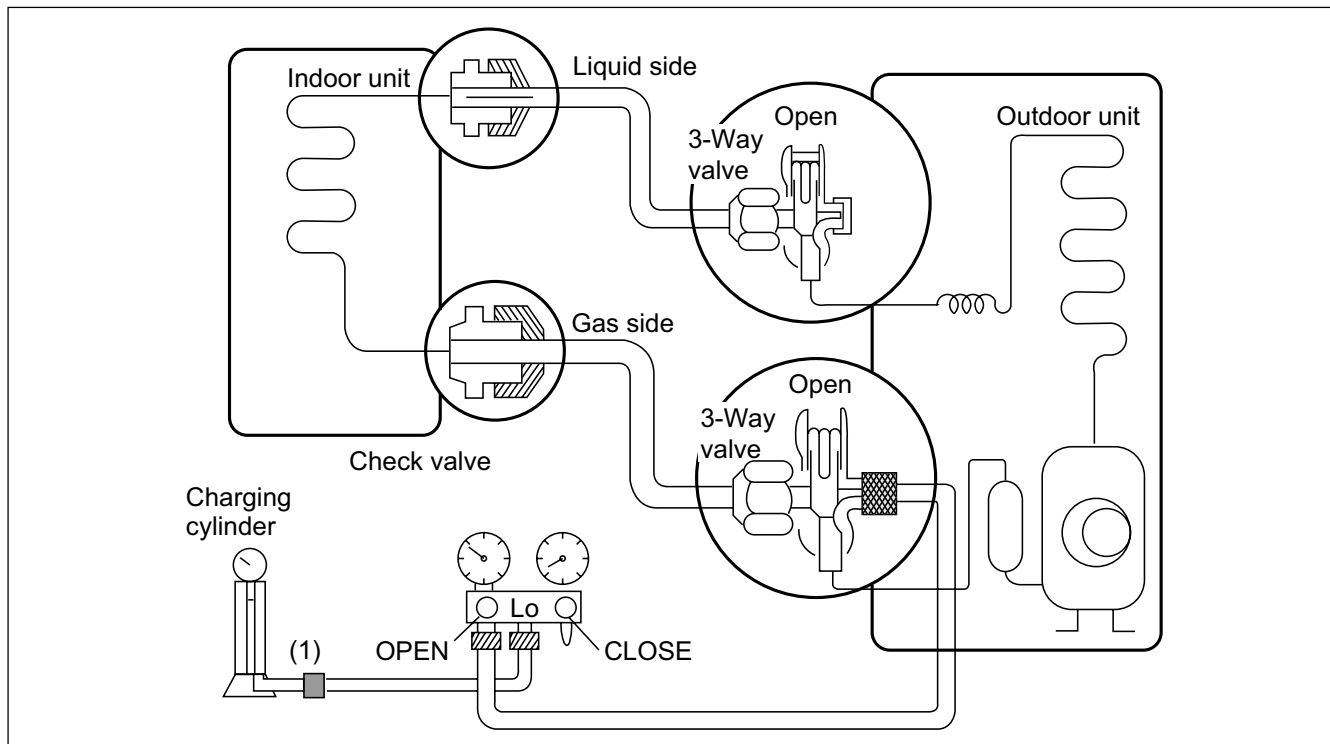

### • Procedure

**(1) Connect the charge hose to the charging cylinder.**

- Connect the charge hose which you disconnected from the vacuum pump to the valve at the bottom of the cylinder.
- If you are using a gas cylinder, also use a scale and reverse the cylinder so that the system can be charged with liquid.

**(2) Purge the air from the charge hose.**

- Open the valve at the bottom of the cylinder and press the check valve on the charge set to purge the air. (Be careful of the liquid refrigerant). The procedure is the same if using a gas cylinder.

**(3) Open the valve (Lo side on the charge set and charge the system with liquid refrigerant.**

- If the system can not be charged with the specified amount of refrigerant, it can be charged with a little at a time (approximately 150g each time) while operating the air conditioner in the cooling cycle; however, one time is not sufficient, wait approximately 1 minute and then repeat the procedure (pumping down-pin).

This is different from previous procedures. Because you are charging with liquid refrigerant from the gas side, absolutely do not attempt to charge with larger amounts of liquid refrigerant while operating the air conditioner.

**(4) Immediately disconnect the charge hose from the 3-way valve's service port.**

- Stopping partway will allow the gas to be discharged.
- If the system has been charged with liquid refrigerant while operating the air conditioner turn off the air conditioner before disconnecting the hose.

**(5) Mount the valve stem nuts and the service port nut.**

- Use torque wrench to tighten the service port nut to a torque of 1.8 kg.m.
- Be sure to check for gas leakage.

**Note: the information above is for reference only.**

# 10. Removal Procedure

## 10.1 Removal Procedure of Indoor Unit

 **Warning** Be sure to wait 10 minutes or more after turning off all power supplies before disassembling work.

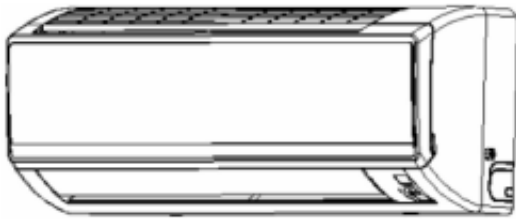
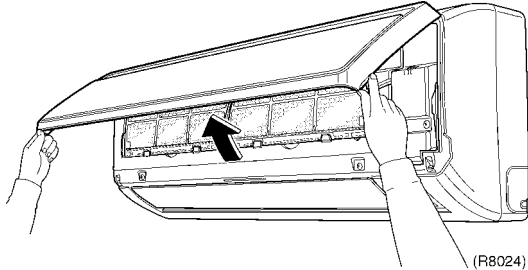
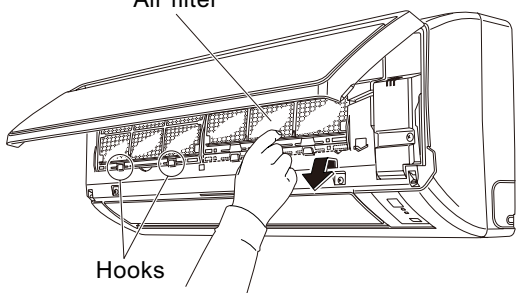
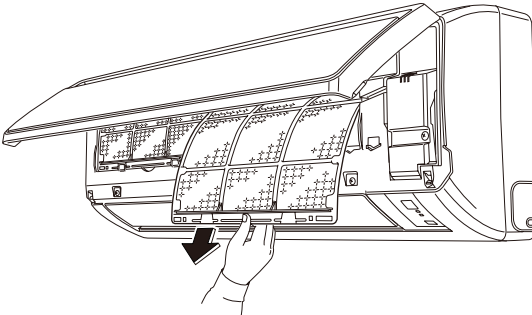
Step	Procedure	Points
1. External features		<ul style="list-style-type: none"> <li>■ If ON/OFF button is kept pushing for 5 seconds, a forced cooling operation will be carried out for approx. 15minutes.</li> </ul>
2. Removing air filters	<p>1 Pull protrusions on left and right sides of panel with fingers and open front grille all the way.</p>  <p>(R8024)</p> <p>2 Lift center section of air filter and disengage hooks.</p>  <p>3 Remove air filter by pulling forward.</p> 	<ul style="list-style-type: none"> <li>■ Left and right filters are interchangeable.</li> <li>■ To re-install, insert air filter along the guide.</li> </ul>

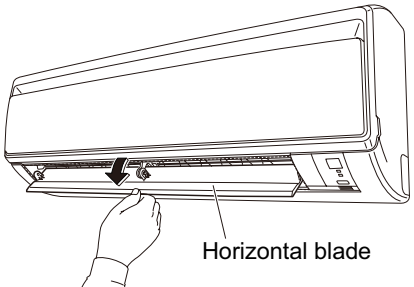
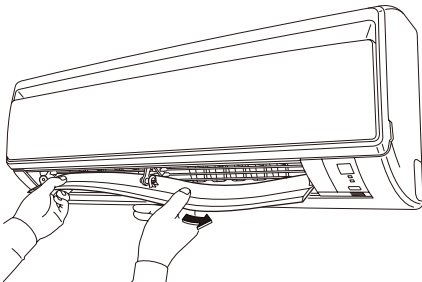
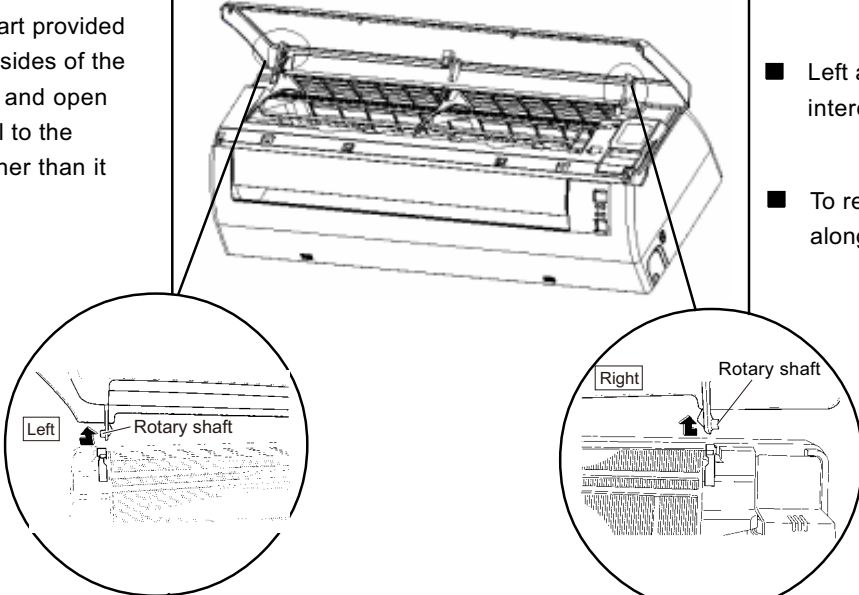
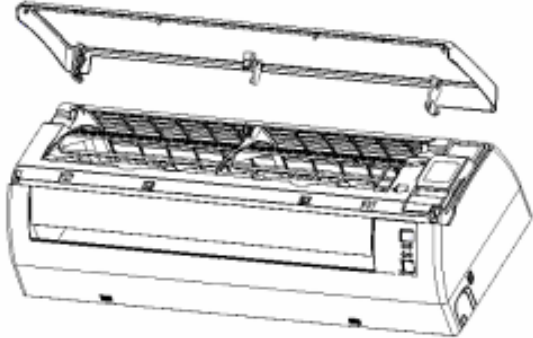
Step	Procedure	Points
3. Opening and shutting front panel		
1	<p>Pull down horizontal blade by pulling forward.</p> 	<p>Support the front panel by one hand, while remove the rotation axis at the upper center by the other hand.</p>
2	<p>Remove horizontal blade by pulling forward.</p> 	<ul style="list-style-type: none"> <li>■ And pull out the front panel forward to remove.</li> </ul>
3	<p>Hook a finger onto the projection part provided on the both sides of the unit's panel and open up the panel to the position higher than it will stop.</p> 	<ul style="list-style-type: none"> <li>■ Left and right filters are interchangeable.</li> <li>■ To re-install, insert air filter along the guide.</li> </ul>
4	<p>Remove the front panel from the unit.</p> 	

**Removal Procedure**

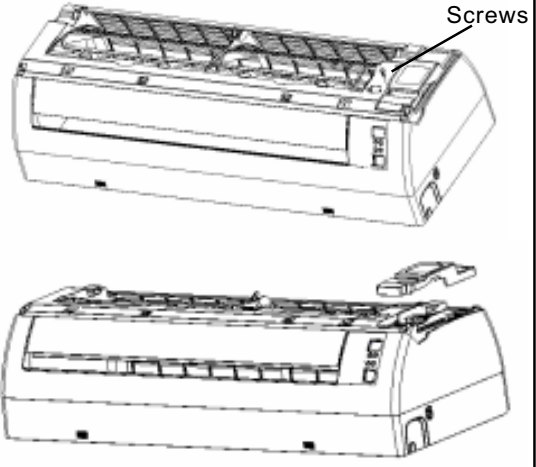
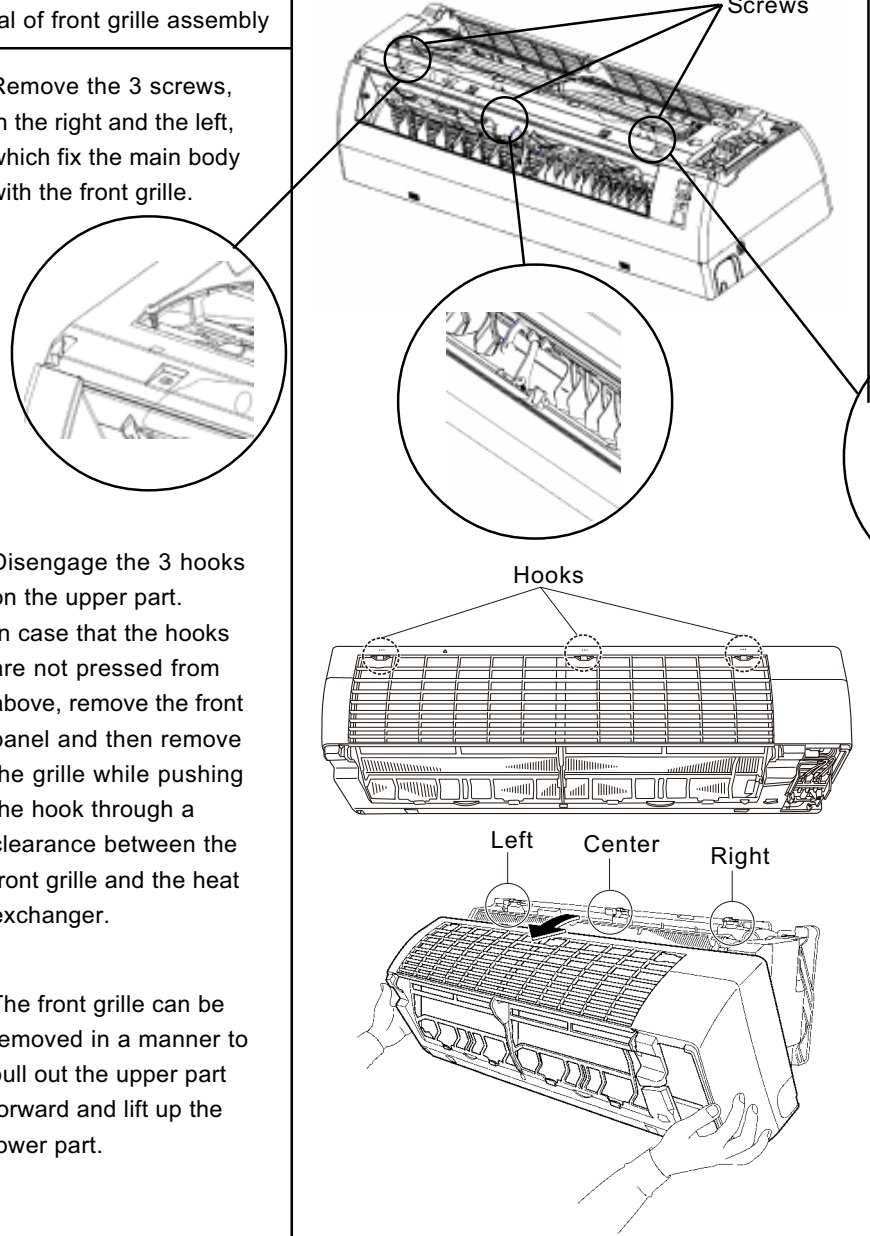
Step	Procedure	Points
<p>4. Opening and closing of service cover</p> <p>1 Remove a service cover mounting screw. Open service cover upward.</p>		<ul style="list-style-type: none"> <li>■ A switch for field setting is not provided in particular.</li> </ul>
<p>5. Removal of front grille assembly</p> <p>1 Remove the 3 screws, in the right and the left, which fix the main body with the front grille.</p> <p>2 Disengage the 3 hooks on the upper part. In case that the hooks are not pressed from above, remove the front panel and then remove the grille while pushing the hook through a clearance between the front grille and the heat exchanger.</p> <p>3 The front grille can be removed in a manner to pull out the upper part forward and lift up the lower part.</p>		<ul style="list-style-type: none"> <li>■ Screw stoppers inside the flap which were equipped in the existing models are not provided.</li> <li>■ At the upper part there are 2 hooks in the left and the right.</li> <li>■ Disengage the hooks by pressing knobs with a screwdriver.</li> </ul>

Step	Procedure	Points
6. Remove the Vertical blade		
1	<p>Unfasten the hooks at the upper 2 positions.</p>	
2	<p>Unfasten the 3 hooks at the shaft mounting part by pressing them with a flat screwdriver.</p>	<ul style="list-style-type: none"> <li>■ A set of vertical blade has 6 fins as on ASSY. (It is impossible to replace only one fin.)</li> <li>■ The set of vertical blades is not marked for difference between right and left.</li> </ul>
3	<p>Remove the vertical blade.</p>	<ul style="list-style-type: none"> <li>■ Repeat the same procedure to remove the vertical blade on the other side.</li> </ul>

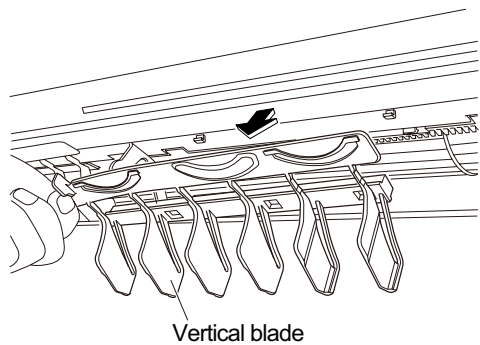
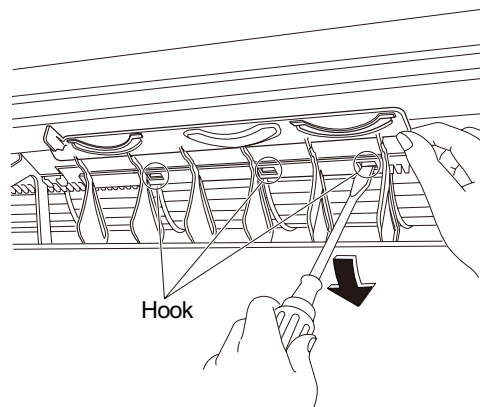
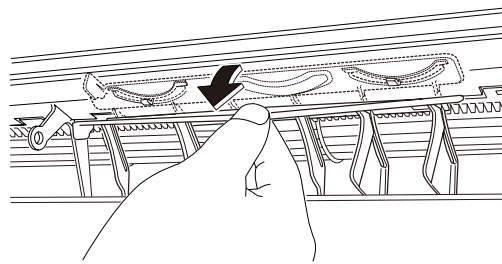
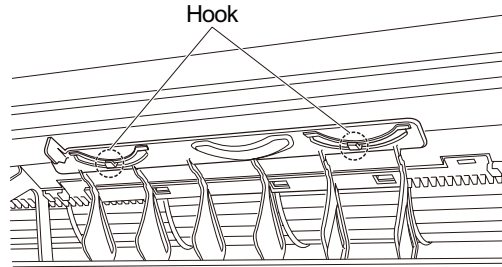

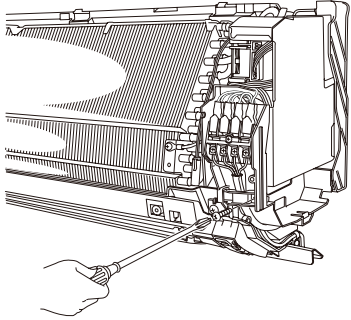
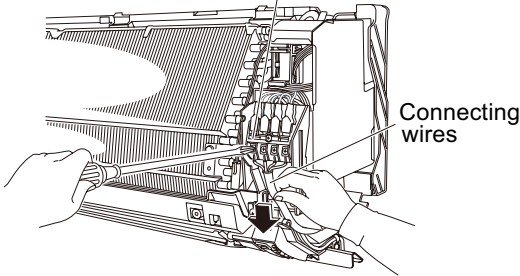
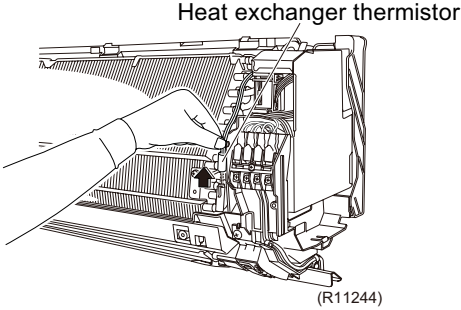
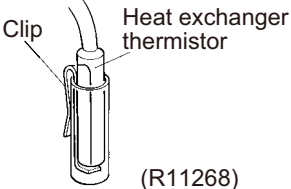
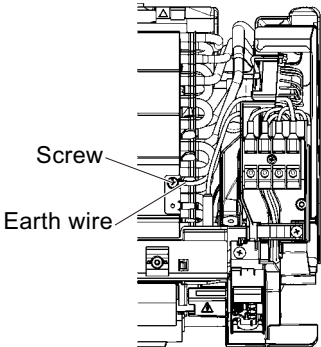

**Removal Procedure**

Step	Procedure	Points
7. Remove electrical box		
1	Disconnect the Cable clamp 	<ul style="list-style-type: none"> <li>Pay attention to the direction of the retainer of the thermistor so that the retainer will not touch the harness (same as the existing models.)</li> </ul>
2	Disconnect the connection wires. 	
3	Remove Temperature Sensor 	<ul style="list-style-type: none"> <li>Take care not to lose the clip of thermistor.</li> </ul> 
4	Remove a screw on the terminal board. 	<ul style="list-style-type: none"> <li>The electrical box can be removed instead of disengaging the terminal board.</li> </ul>

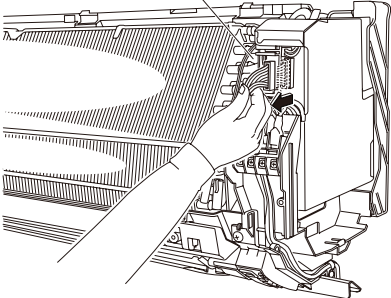
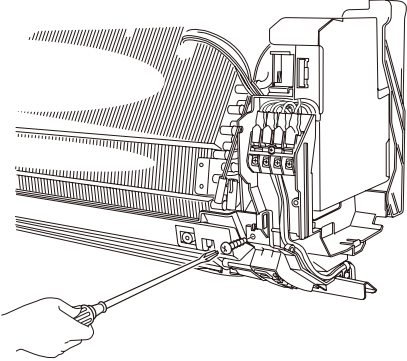
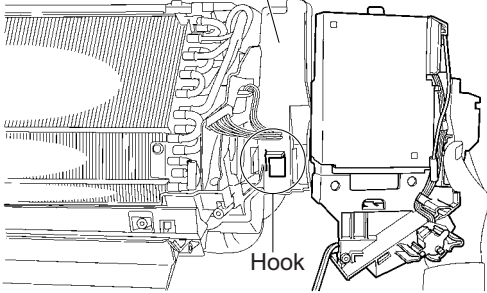
Step		Procedure	Points
5	Remove fan motor Signal Wire	<p data-bbox="687 342 927 371">fan motor Signal Wire</p> 	
6	Remove a screw on the electrical box.		
7	Pull up the electrical box forward to remove.	<p data-bbox="751 1144 895 1173">Bottom frame</p>  <p data-bbox="799 1429 858 1458">Hook</p>	

**Removal Procedure**

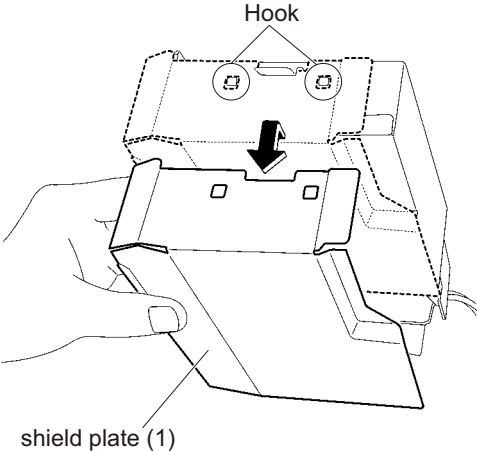
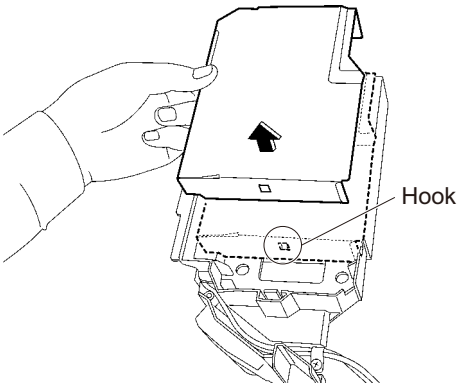
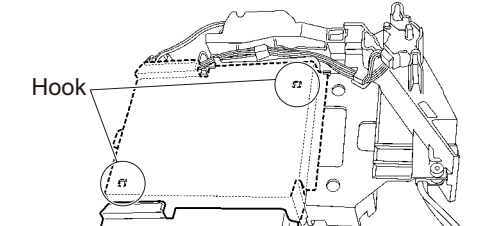
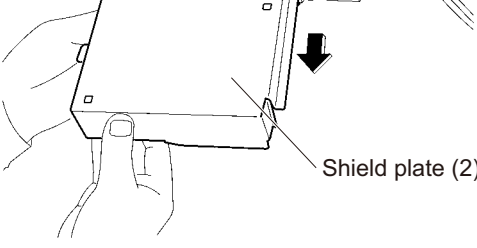

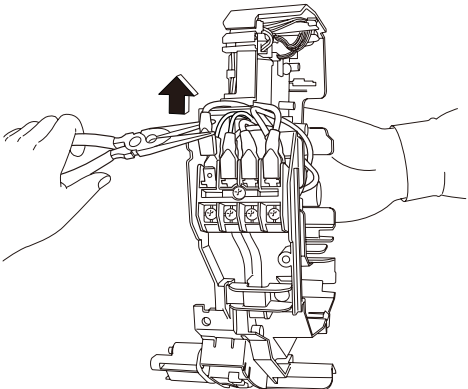
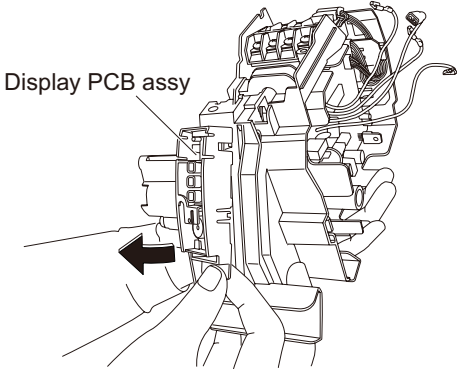
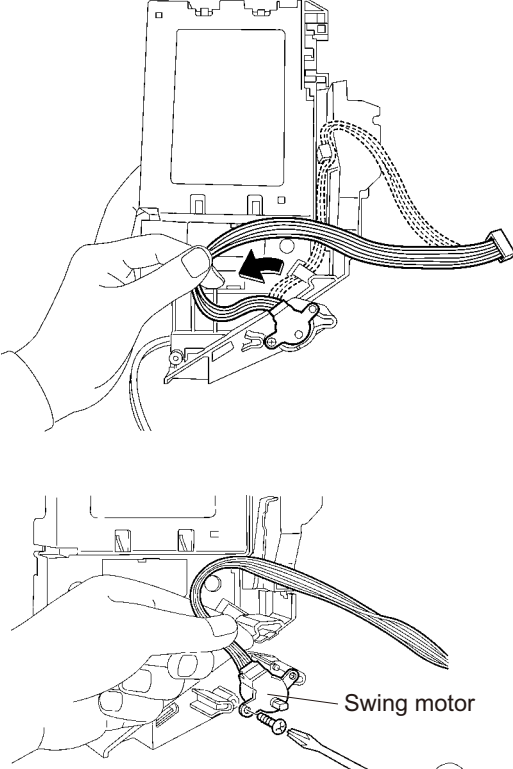
Step	Procedure	Points
8. Remove the shield plate.		
1	<p>Unfasten the hooks at the upper 2 positions of the shield plate.</p> 	
2	<p>Unfasten the hook at the lower position, and remove the shield plate (1).</p> 	<p>■ Remove the electrical box according to the "Removal of Electrical Box".</p>
3	<p>Lift the shield plate (2) and unfasten the 2 hooks.</p> 	
4	<p>Slide the shield plate (2) and remove it.</p> 	

Step		Procedure	Points
2	Take off Wiring terminal		
3	Remove Display PCB Sub-Assy.		
4	Remove Swing motor.		<p>(R8036)</p>

## Removal Procedure

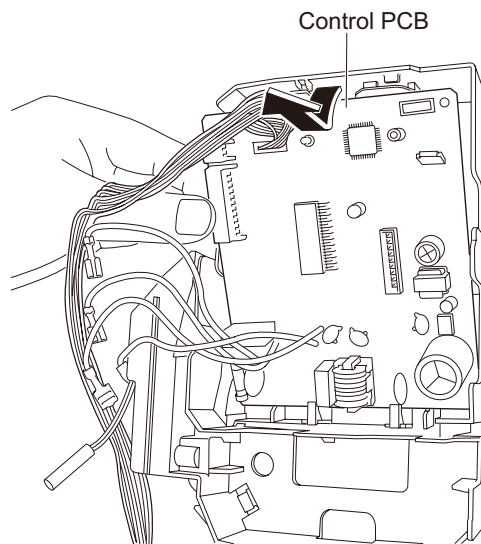
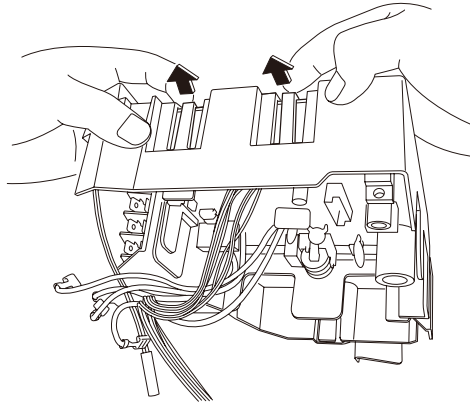
Step	Procedure	Points
5	To remove the control PCB, unfasten the 2 hooks at the upper part from the rear side.	
6	Lift up the upper part of the control PCB, and remove it.	<ul style="list-style-type: none"><li>■ The control PCB is integrated with the power supply PCB.</li></ul>



Step	Procedure	Points
9. Disconnect the refrigerant piping.		
1	Lift the indoor unit by a wooden base.	<p> <b>CAUTION</b></p> <p>If gas leaks, repair the spot of leaking, then collect all refrigerant from the unit. After conducting vacuum drying, recharge proper amount of refrigerant.</p>
2	Place a plastic sheet under the drain pan as remaining drain may leak.	<p> <b>CAUTION</b></p> <p>Do not contaminate any gas (including air) other than the specified refrigerant (R-410A) into refrigerant cycle. (Contaminating of air or other gas causes abnormal high pressure in refrigerating cycle, and this results in pipe breakage or personal injuries.)</p>
3	Disconnect the flare nut for gas piping by 2 wrenches.	<ul style="list-style-type: none"> <li>■ Pay attention so that the residual water in the drain will not make the floor wet.</li> </ul>
4	Disconnect the flare nut for liquid piping by 2 wrenches.	<ul style="list-style-type: none"> <li>■ In case that a drain hose is buried inside a wall, remove it after the drain hose in the wall is pulled out.</li> <li>■ Use two wrenches to disconnected pipes.</li> <li>■ When disconnecting pipes, cover every nozzle with caps so as not to let dust and moisture in.</li> </ul>

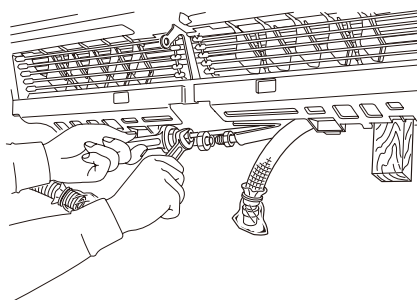
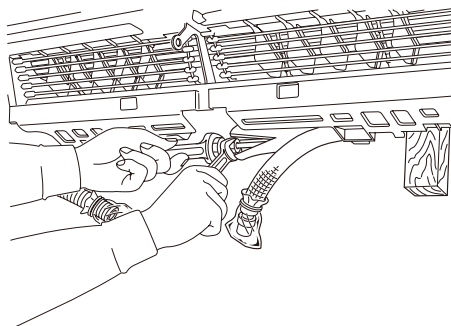
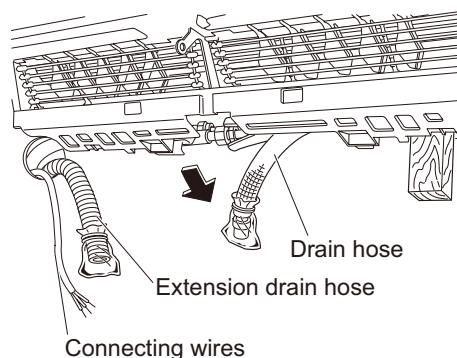
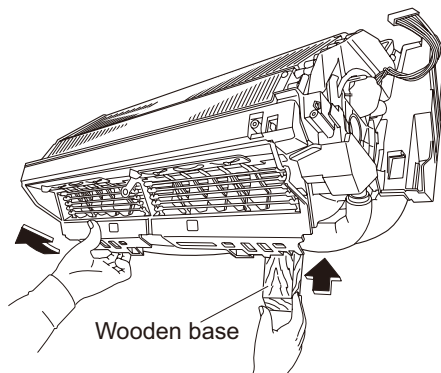

Removal Procedure

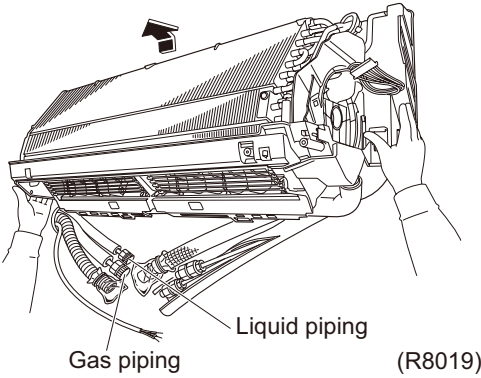
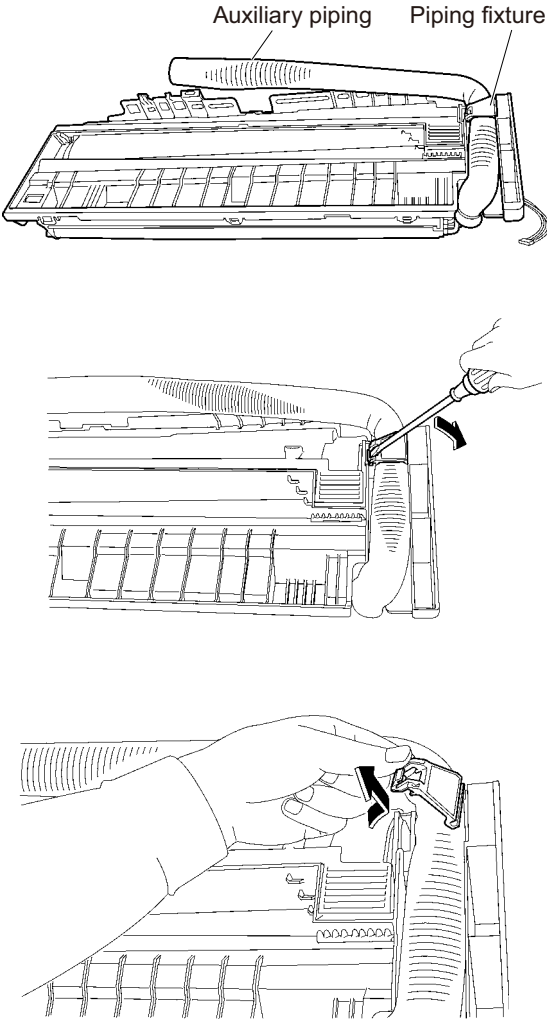
Step	Procedure	Points
10. Remove the indoor unit.		
1	<p>Remove the indoor unit from the installation plate.</p> 	<ul style="list-style-type: none"><li>■ When the pipings are disconnected, protect the both openings from entering moisture.</li></ul>
2	<p>Release the hook of the piping fixture on the back of the unit.</p> 	

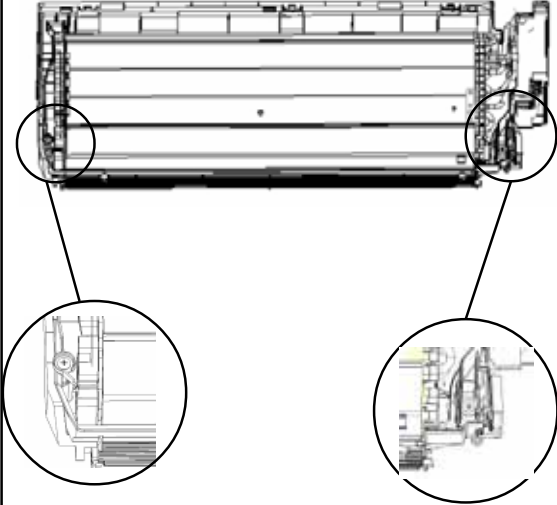
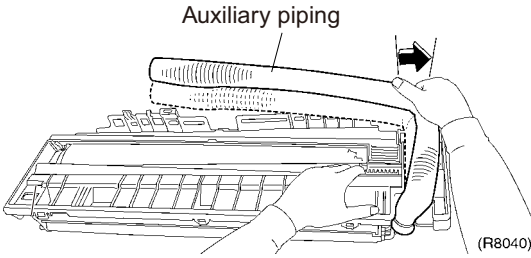
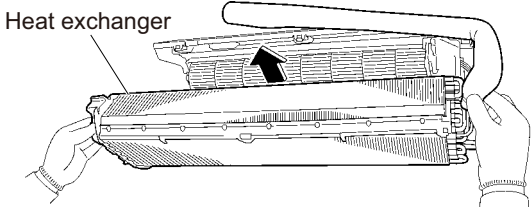
Step	Procedure	Points
3	<p>Loosen the 2 screws, in the right and the left, which fix the Evaporator Assy.</p> 	
4	<p>Widen the auxiliary piping to the extent of 10°~20°.</p> 	
5	<p>Pull the heat exchanger to the front side to undo the hooks completely, and then lift it.</p> 	

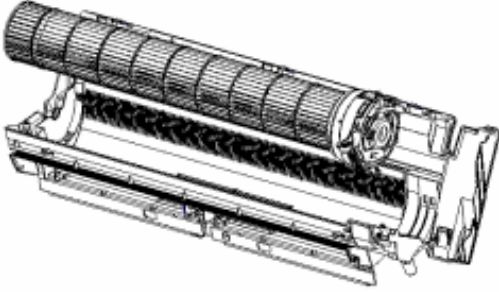
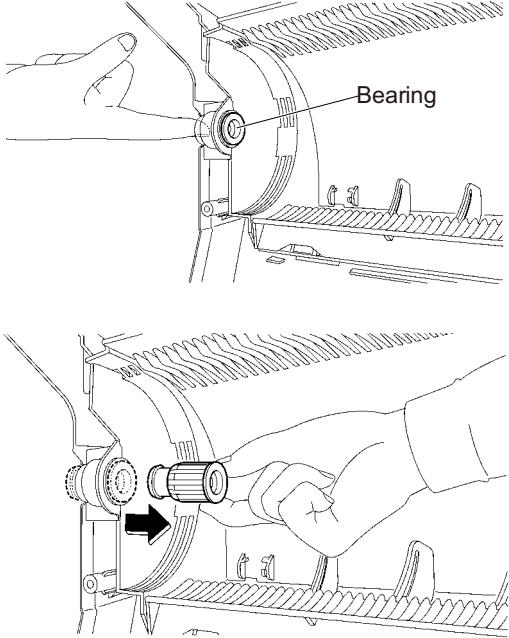
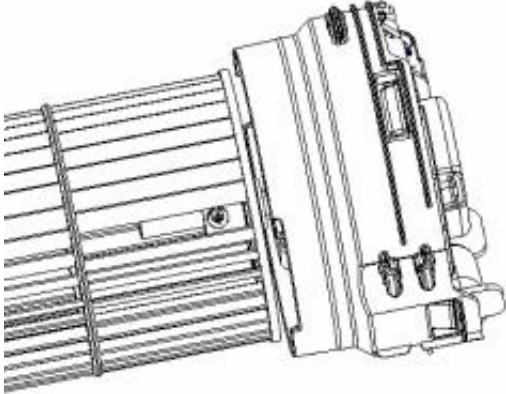

**Removal Procedure**

Step	Procedure	Points
11. Remove Cross Flow Fan Fan Motor	<p data-bbox="181 398 475 461">1 Remove Cross Flow Fan Fan Motor</p> 	
12. Remove Ring of Bearing	 <p data-bbox="975 1406 1034 1429">(R8050)</p>	
13. Remove Cross Flow Fan and Motor Sub-Assy screw.		

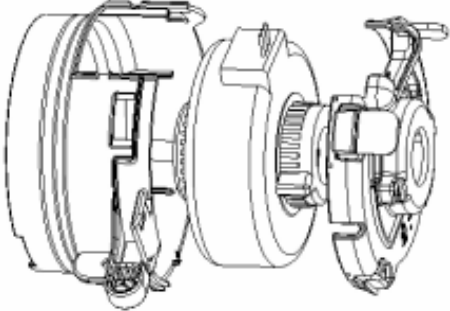
Step	Procedure	Points
14. Remove Motor Sub-Assy		
1		Remove Motor Sub-Assy
15. Remove Fan Motor		

## 10.2 Removal Procedure of Outdoor Unit



**Warning**

**Be sure to wait 10 minutes or more after turning off all power supplies before disassembling work.**

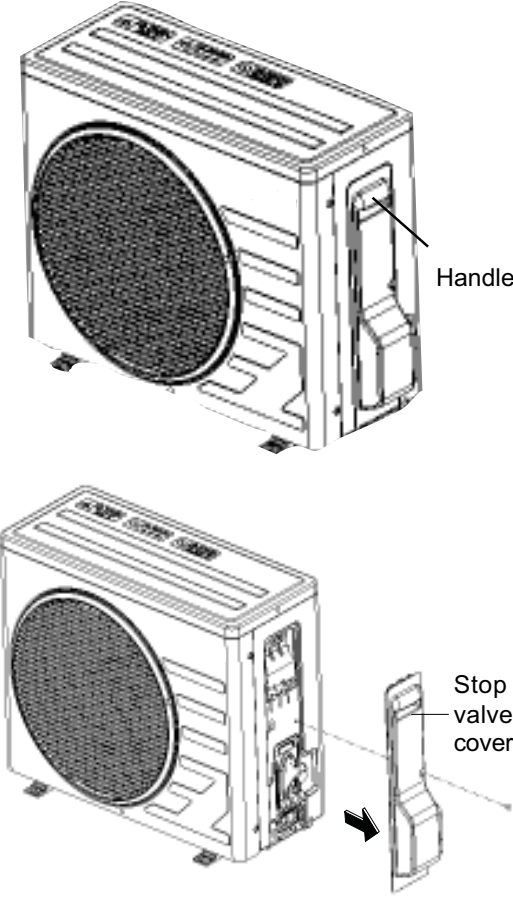
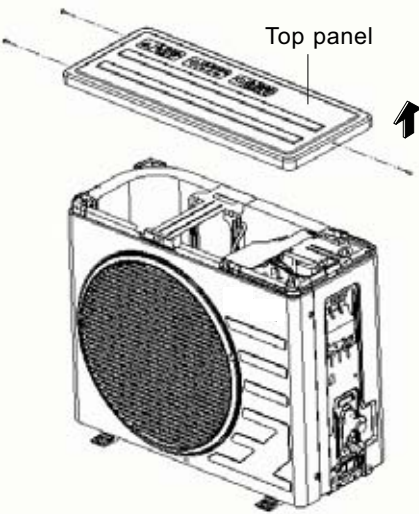
Step	Procedure	Points
<p>1. Features</p> <p>1</p>	<p>Loosen the screw of the stop valve cover. Pull down the stop valve cover and remove it.</p> 	<ul style="list-style-type: none"> <li>■ The stop valve cover has 6 hooks.</li> </ul>
<p>2. Removing air filters</p> <p>1</p>	<p>Loosen the 3 screws (front, right, left) and lift the top panel.</p> 	

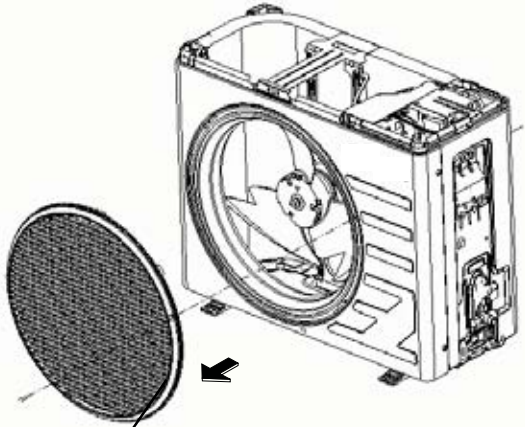
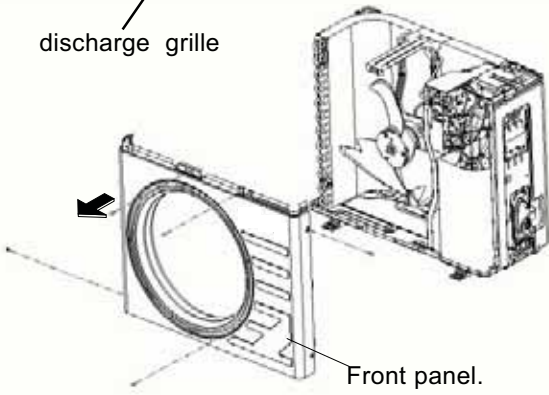
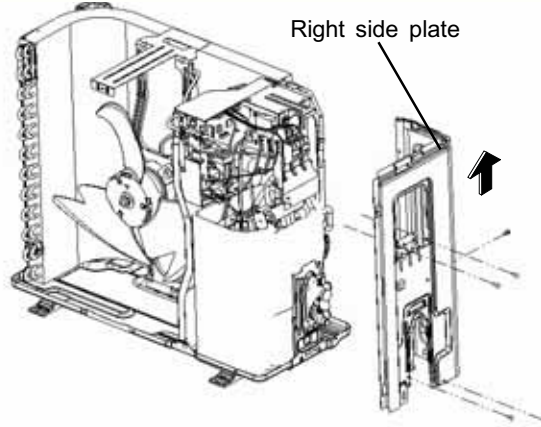
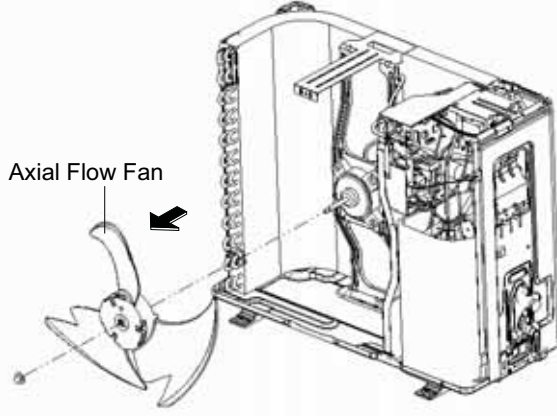
Step		Procedure	Points
2	Loosen the 1 screws and remove the discharge grille.	 <p>discharge grille</p>	
3	Loosen the 5 screws of the front panel.	 <p>Front panel.</p>	<ul style="list-style-type: none"> <li>■ Lift the front panel and remove it while pushing the right side panel inwards.</li> </ul>
4	Remove 5 screws among right side plate, side plate of condenser and valve support. Then lift the right side plate to remove it.	 <p>Right side plate</p>	
4.Remove the fan motor			<ul style="list-style-type: none"> <li>■ The screw has reverse winding.</li> </ul>
1	Remove nut of fan blade and then remove the axial flow fan blade.	 <p>Axial Flow Fan</p>	<ul style="list-style-type: none"> <li>■ Remove the propeller fan.</li> </ul>

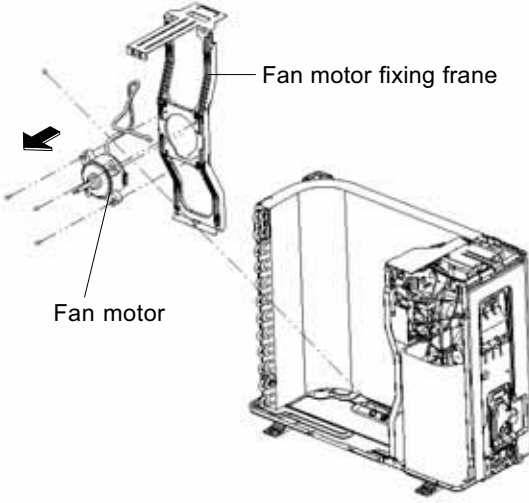
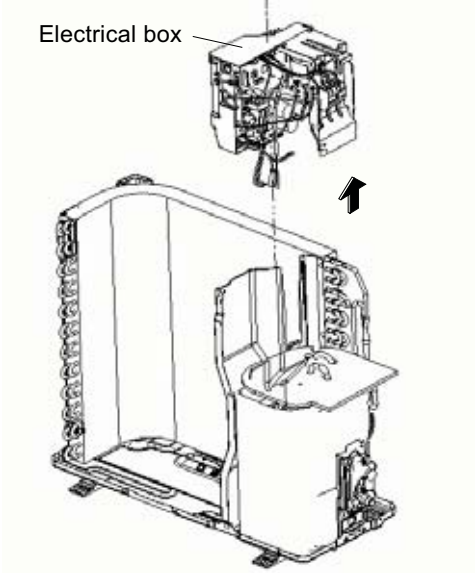
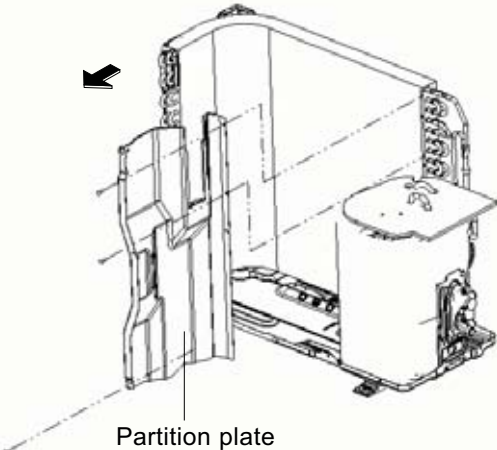
Step	Procedure	Points
2	<p>Unscrew 4 tapping screws fixing motor, pull out the leading wire pin of motor to remove motor. Unscrew 2 tapping screws fixing motor support, then lift it upward to remove motor support.</p>	 <p>■ M4×16 ■ DC fan motor</p>
5.Remove the electrical box.		
1	<p>Unscrew 2 screws fixing electric box cover by screwdriver, then lift it upward to remove electric box cover. Unscrew screws fixing electric box sub-assy by screwdriver, loosen the tie line and pull out wiring terminal, then lift it upward to remove electric box sub-assy.</p>	
6.Remove the partition plate.		
1	<p>Loosen the 2 screws.</p>	
2	<p>The partition plate has a hook on the lower side. Lift and pull the partition plate to remove.</p>	 <p>■ The partition plate is fixed to the bottom frame with a hook.</p>

Step	Procedure	Points
7.Remove the sound blanket.		
1	Lift and remove the sound blanket (top).	
2	Untie the strings and open the sound blanket.	<ul style="list-style-type: none"> <li>■ Since the piping ports on the sound blanket are torn easily, remove the blanket carefully.</li> </ul>
3	Lift and remove the sound blanket (body) as it is opened.	
4	Pull the sound blanket (inner) out.	<ul style="list-style-type: none"> <li>■ Since the piping ports on the sound blanket are torn easily, remove the blanket carefully.</li> </ul>
8.Remove the partition plate.		
1	Loosen the screw of the four way valve coil.	<ul style="list-style-type: none"> <li>■ Provide a protective sheet or a steel plate so that the brazing flame cannot influence peripheries.</li> <li>■ Be careful so as not to break the pipes by pressing it excessively by pliers when withdrawing it.</li> </ul> <p><b>⚠ Caution</b> Be careful about the four way valve, pipes and so on, which were heated up by a gas brazing machine, so as not to get burnt your hands.</p>

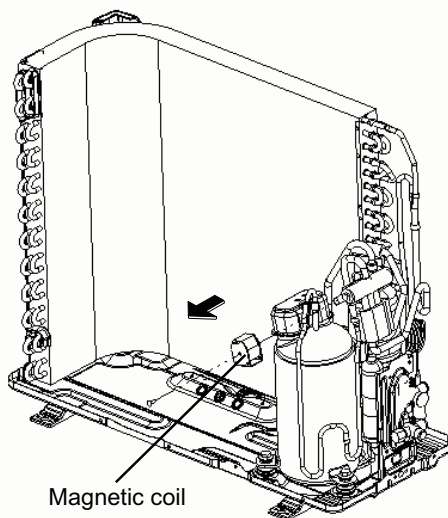
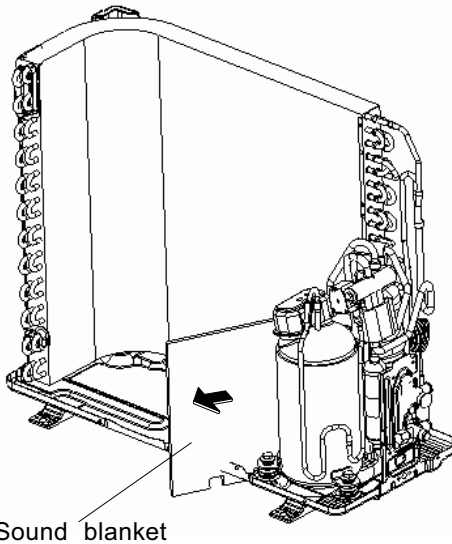
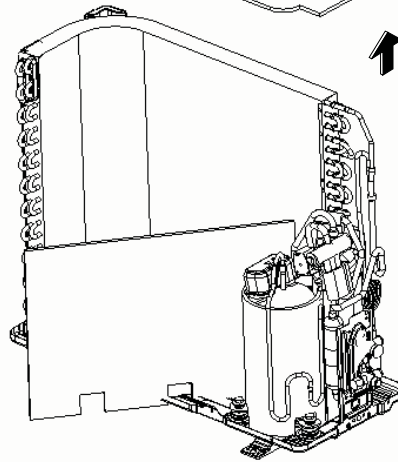
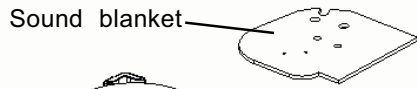

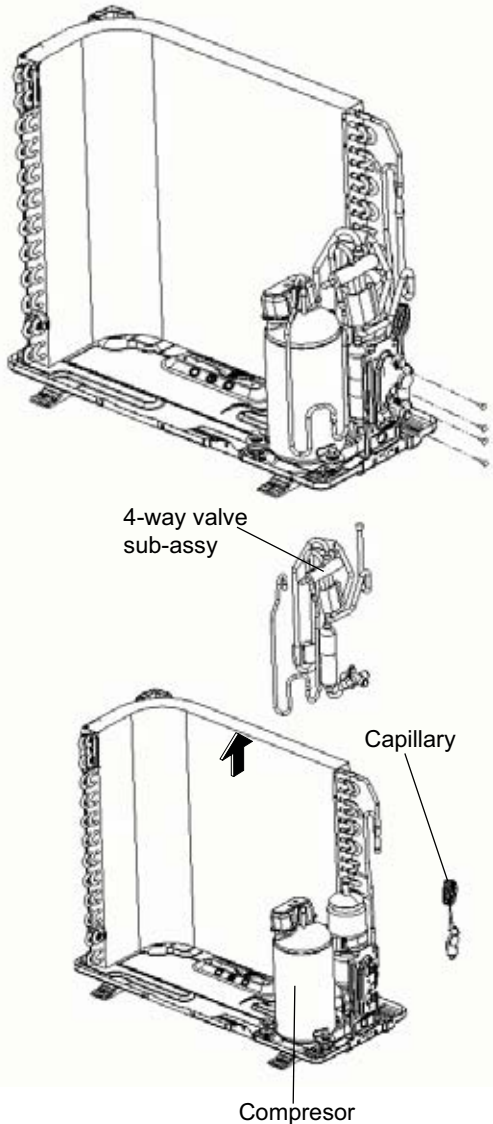
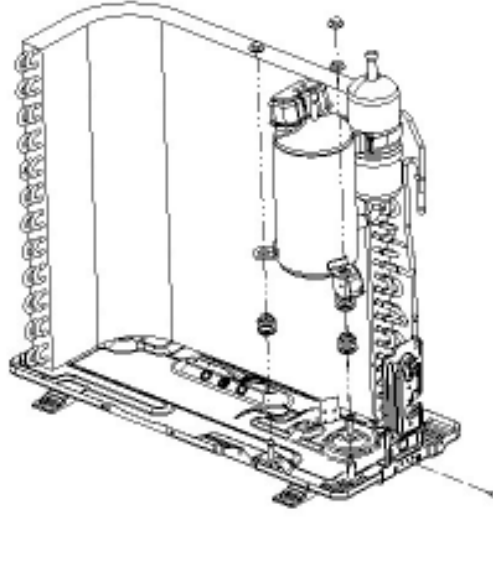

Step	Procedure	Points
9.Remove compressor		
1	<p>Unsolder the spot weld of capillary, valve and outlet of condenser to remove capillary. Be sure do not make welding slag block the capillary during replacing capillary.</p>	
2	<p>Remove the 2 screws fixing the gas valve. Solder off the weld spot connecting gas valve and air return pipe and remove the gas valve. (Note: it is necessary to warp the gas valve when soldering off the welding spot.) Remove the 2 screws fixing liquid valve. Solder off the welding spot connecting liquid valve and remove the liquid valve.</p>	 <p>The diagram illustrates the removal of the 4-way valve sub-assembly and the capillary tube. It shows a side view of the condenser unit with the compressor. A callout shows the 4-way valve sub-assembly being removed. Another callout shows the capillary tube being removed from the condenser. An arrow points to the capillary tube connection point on the condenser.</p>
3	<p>Solder off the pipe connected with the compressor.</p>	
4	<p>Remove the 3 footing screws of the compressor and remove the compressor.</p>	 <p>The diagram shows the compressor being removed from the condenser unit. It illustrates the three footing screws being removed from the base of the compressor, and the compressor being lifted out of the condenser frame.</p>

# 11. Care and Cleaning

## 11. Cleaning Refrigeration System

In addition to replacement of compressor, capillary and strainer, the whole refrigeration system shall be completely cleaned, as the refrigerant in the system is contaminated by a lot of acid oxydum generated from insulation breakdown, turn-to-turn short circuit or burning out of winding of compressor's motor during malfunction.

The refrigeration oil in the mild-contaminated refrigeration system shall be limpid when discharging from the process pipe of compressor. It shall be faint yellow (normally white) if testing by lacmus paper. While severe- contaminated, it is black and the testing lacmus paper becomes red 5min later.

The abluent R113 is used to clean the system.

Confirm the contamination degree by checking color and smell of refrigerant before cleaning the system, as shown in the figure.

Check the refrigeration oil for impurity by discharging a little of oil from the process pipe of compressor.

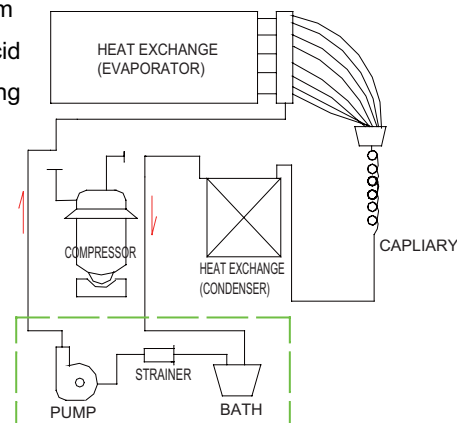

### Cleaning Procedure:

1. Charge the abluent R113 into the fluid bath. Start up the pump to clean the system about 1hr if mid-contaminated or 3-4hr if severe-contaminated. In order to avoid blockage of strainer, the abluent and the strainer shall be replaced after long-time cleaning.

2. The abluent after cleaning of the system can be recovered from liquid pipe and it can be reused after processing.

3. The refrigeration pipeline should be blown off by nitrogen and dried after cleaning.

Disconnect the parts in the broken frame with the pipeline and install blind plates on ring flanges of liquid suction and pumping pipes before drying process. In order to quickly dry the system, make vacuum pumping while blow off hot wind to external refrigeration pipeline.

Afterwards, reassemble the pipeline (charge nitrogen while welding) and replace the compressor and strainer.

### Cautions:

1. In order to avoid leakage of abluent, pressure hose should be adopted and joint parts should be tightly wrapped.

2. The expansion valve adopted by the unit shall be replaced by by-pass pipe.

3. Remove the moisture contained in the refrigeration system.

4. Use nitrogen to blow off the acid generated from burning out of compressor

## 11.2 Cleaning of Heater Exchanger

In order to improve energy efficiency, the heater exchanger, especially the condenser in the outdoor unit, should be cleaned after operation of several years.



**PARTS GUIDE**

# POLAR SERIES

**ASH-18AIP PT, ASH-24AIP PT**





Exploded view of model ASH-09AIP PT

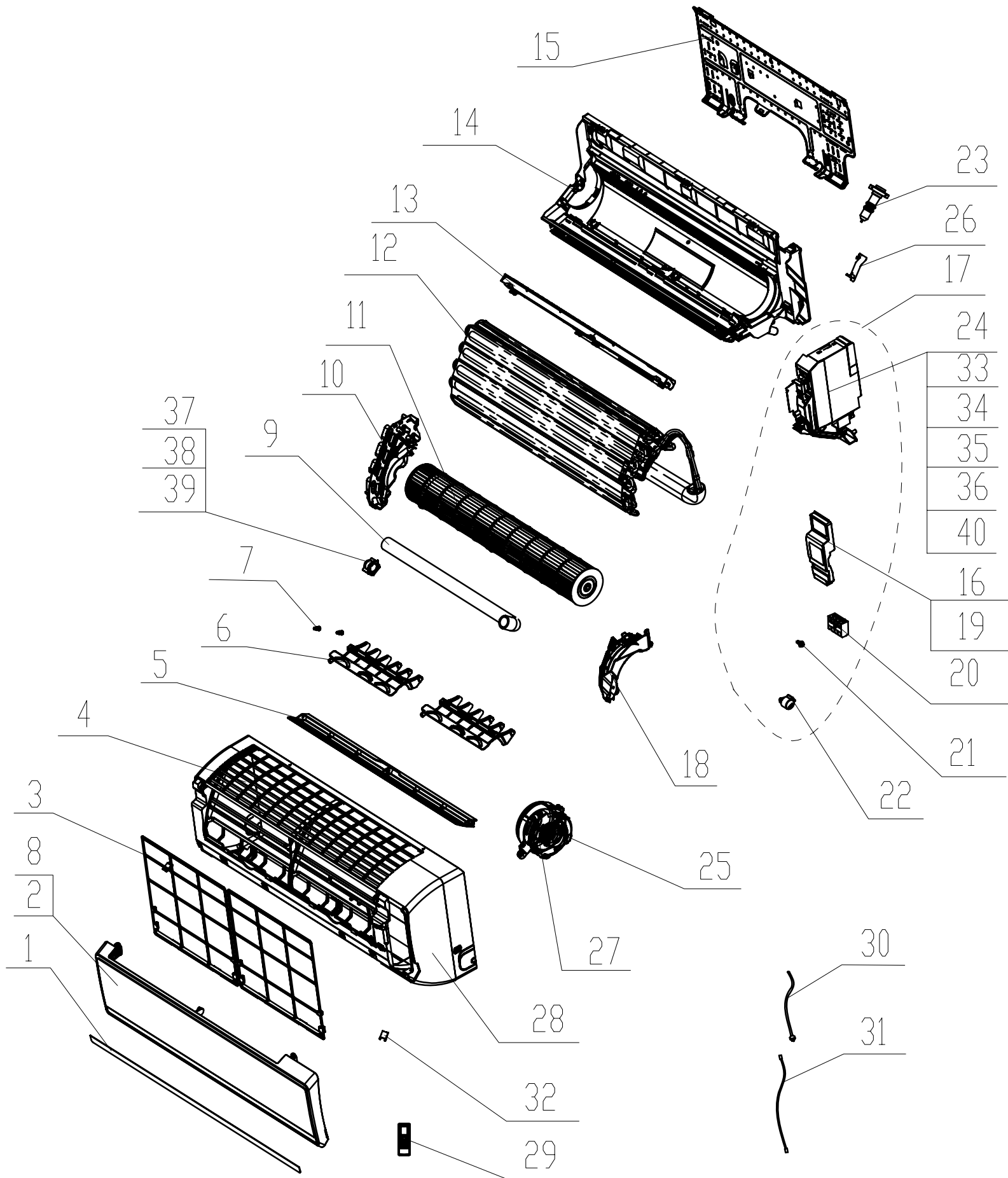

No	Description	Part Code	Note	Qty	Price Code
<b>MODEL: ASH-09AIP PT indoor</b>					
1	Decorative Strip	none		0	
2	Front Panel	2722325002		1	AN
3	Filter Sub-Assy	1112208201		2	AD
4	Front Case	20012324		1	AU
5	Guide Louver	10512119		1	AF
6	Air Louver	10512160		2	AK
7	Shaft of Guide Louver	1054202001		2	AB
8	Front Panel Assy	2001237604_K73282		1	AN
9	Drainage Pipe Sub-assy	0523204101		1	AD
10	Evaporator Support	24212108		1	AK
11	Cross Flow Fan	10352423		1	AM
12	Evaporator Assy	01002270		1	BE
13	Helicoid tongue	26112486		1	AL
14	Rear Case assy	2220229501		1	BA
15	Wall Mounting Frame	0125201801A		1	AK
16	Electric Box Cover	2012210601		1	AF
17	Electric Box Assy	20302894		1	BB
18	Motor Press Plate	26112191		1	AH
19	Electric Box Cover Sub-Assy	2012210901		1	AF
20	Terminal Board	42011233		1	AF
21	Crank	73012005		1	AB
22	Step Motor MP24BA	1521210701		1	AG
23	Pipe plug (outlet)	76712020		1	AB
24	Electric Box	20112086		1	AK
25	Motor Sub-Assy	15002020		1	AZ
26	Baffle Plate	26112218		1	AH
27	Fan Motor FN10V-PG	15012141		1	AX
28	Front Case Assy	2001237501		1	AU
29	Remote Controller YB1F2(XFAN)	305100611_K73282		1	AT
30	Power Cord	4002046412		1	AM
31	Connecting Cable	400205236		1	AN
32	Screw Cover	24252019		1	AB
33	Main Board M819F2E112J(MI)	301485201		1	AY
34	Capacitor CBB61	3301000213		1	AE
35	Ambient Temperature Sensor	390000453		1	AD
36	Relay	none		0	
37	Fan Bearing	76512210		1	AC
38	Damping washer sub-assy	76512011		1	AD
39	Axile Bush sub-assy	10542024		1	AC
40	Electric Box Sub-Assy	20302911		1	BB
	Indicator Light Cover	22242084		1	AE
	Indicator shield cover	22242083		1	AC
	Display Board D8193	30568010		1	AM
	Temperature Sensor	39000305		1	AD
	Cold plasma generator	11140012		1	AP
	Remote Controll Holder YB1A4	27210071		1	AD
	Support of Catechin	24212910		2	AB
	Propeller Axile Bush	1054202101		1	AB

The data are subject to change without notice.

Exploded view of model ASH-12AIP PT

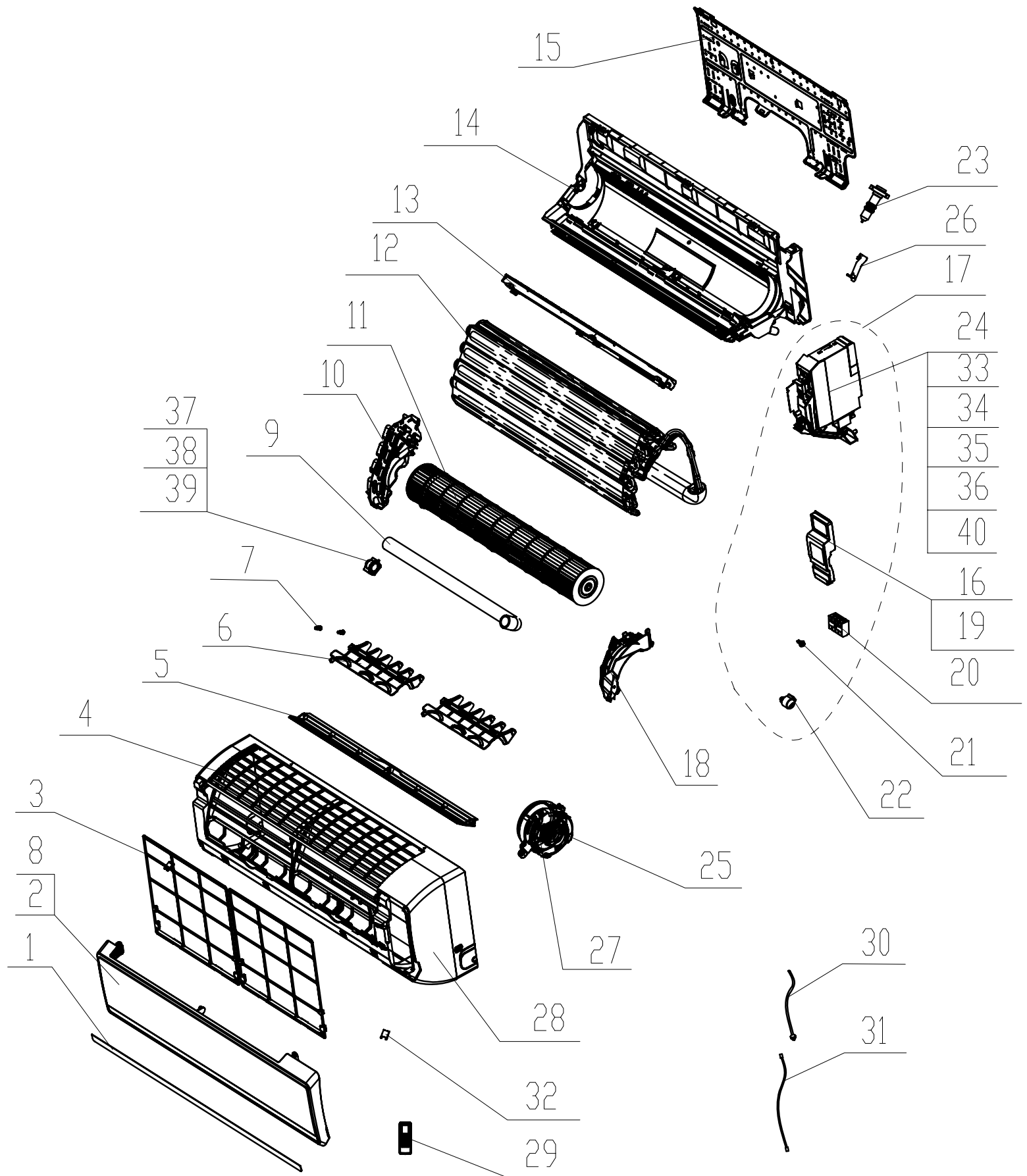

No	Description	Part Code	Note	Qty	Price Code
<b>MODEL: ASH-12AIP PT indoor</b>					
1	Decorative Strip	none		0	
2	Front Panel	2722325002		1	AN
3	Filter Sub-Assy	1112208201		2	AD
4	Front Case	20012324		1	AU
5	Guide Louver	10512119		1	AF
6	Air Louver	10512160		2	AK
7	Shaft of Guide Louver	1054202001		2	AB
8	Front Panel Assy	2001237604_K73282		1	AN
9	Drainage Pipe Sub-assy	0523204101		1	AD
10	Evaporator Support	24212108		1	AK
11	Cross Flow Fan	10352423		1	AM
12	Evaporator Assy	01002745		1	BE
13	Helicoid tongue	26112486		1	AL
14	Rear Case assy	2220229501		1	BA
15	Wall Mounting Frame	0125201801A		1	AK
16	Electric Box Cover	20122106		1	AF
17	Electric Box Assy	2030289401		1	BB
18	Motor Press Plate	26112191		1	AH
19	Electric Box Cover Sub-Assy	20122109		1	AF
20	Terminal Board	42011233		1	AF
21	Crank	73012005		1	AB
22	Step Motor	1521210701		1	AG
23	Pipe plug (outlet)	76712020		1	AB
24	Electric Box	20112086		1	AK
25	Motor Sub-Assy	15002020		1	AZ
26	Baffle Plate	26112218		1	AH
27	Fan Motor FN10V-PG	15012141		1	AX
28	Front Case Assy	2001237501		1	AU
29	Remote Controller YB1F2(XFAN)	305100611_K73282		1	AT
30	Power Cord	4002046412		1	AM
31	Connecting Cable	400205236		1	AN
32	Screw Cover	24252019		1	AB
33	Main Board M819F2E113J(MI)	301485211		1	AY
34	Capacitor CBB61	3301000213		1	AE
35	Ambient Temperature Sensor	390000453		1	AD
36	Relay	none		0	
37	Fan Bearing	76512210		1	AC
38	Damping washer sub-assy	76512011		1	AD
39	Axile Bush sub-assy	10542024		1	AC
40	Electric Box Sub-Assy	2030291101		1	BB
	Indicator Light Cover	22242084		1	AE
	Indicator shield cover	22242083		1	AC
	Display Board	30568010		1	AM
	Temperature Sensor	39000305		1	AD
	Cold plasma generator	11140012		1	AP
	Remote Controll Holder YB1A4	27210071		1	AD
	Support of Catechin	24212910		2	AB
	Propeller Axile Bush	1054202101		1	AB

The data are subject to change without notice.

Exploded view of model ASH-09AIP PT

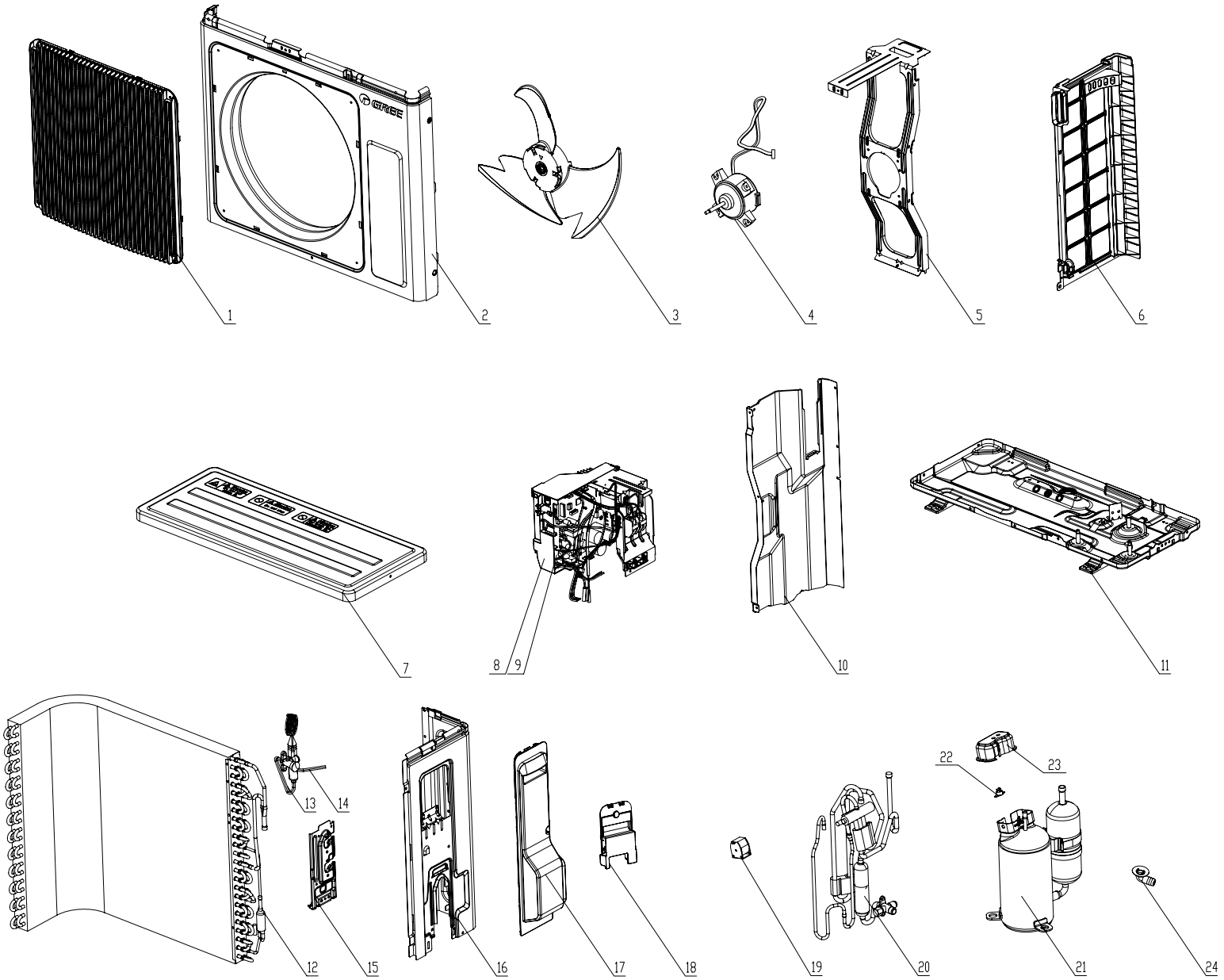

No	Description	Part Code	Note	Qty	Price Code
<b>MODEL: ASH-09AIP PT outdoor</b>					
1	Front Grill	22413017		1	AL
2	Cabinet Sub-assy	0143306101		1	AU
3	Axial Flow Fan Sub-Assy	1033300901		1	AN AN
4	Fan Motor FW30N	15013073		1	AW AW
5	Motor Support	0170312201		1	AN
6	Left Side Plate	20053001		1	AN
7	Top Cover Sub-Assy	01253071		1	AN
8	Electric Box Assy	02613047		1	BL
9	Main Board W8283AW	30148403		1	BF
10	Clapboard	01233088		1	AL
11	Chassis Sub-assy	02803098P		1	AW
12	Condenser Assy	01113463		1	BP
13	Cut off Valve Assy	07133719		1	AP
14	Capillary Sub-assy	03163069		1	AU
15	Valve Support	01713089		1	AE
16	Right Side Plate Sub-Assy	0130318001		1	AM
17	Handle assy	26233046		1	AF
18	Thermal baffle	26113005		1	AD
19	Magnet Coil	4300040050		1	AM
20	4-Way Valve Assy	03123901		1	AZ
21	Compressor and Fittings QXA-B096zC190	00103869G		1	BN
22	Compressor Overload Protector KSD115°C	00183032		1	AQ
23	Terminal Cap	none		1	
24	Drainage Joint	06123024		1	AD
	Filter Board LB809D	30033081		1	AU
	4-Way Valve (R410a)(STF-0108G/SHF-4H)	430004022		1	AX AX
	Silencer	07243045		1	AK
	Compressor Overload Protector(External) 1NT11L6233	00180030		1	AQ
	Compressor Overload Protector HPC115/95U1	00183031		1	AQ
	Terminal Board	42010312		1	AE
	Temperature Sensor	3900030805		1	AH
	Reactor	43130184		1	AS
	Compressor Gasket	76710287		3	AC
	Electrical Heater (Chassis)	76510004		1	AR
	Gas Valve Assy	07103472		1	AP
	Electric Heater(Compressor)	76513004		1	AH

The data are subject to change without notice.



# Exploded view of model ASH-12AIP PT

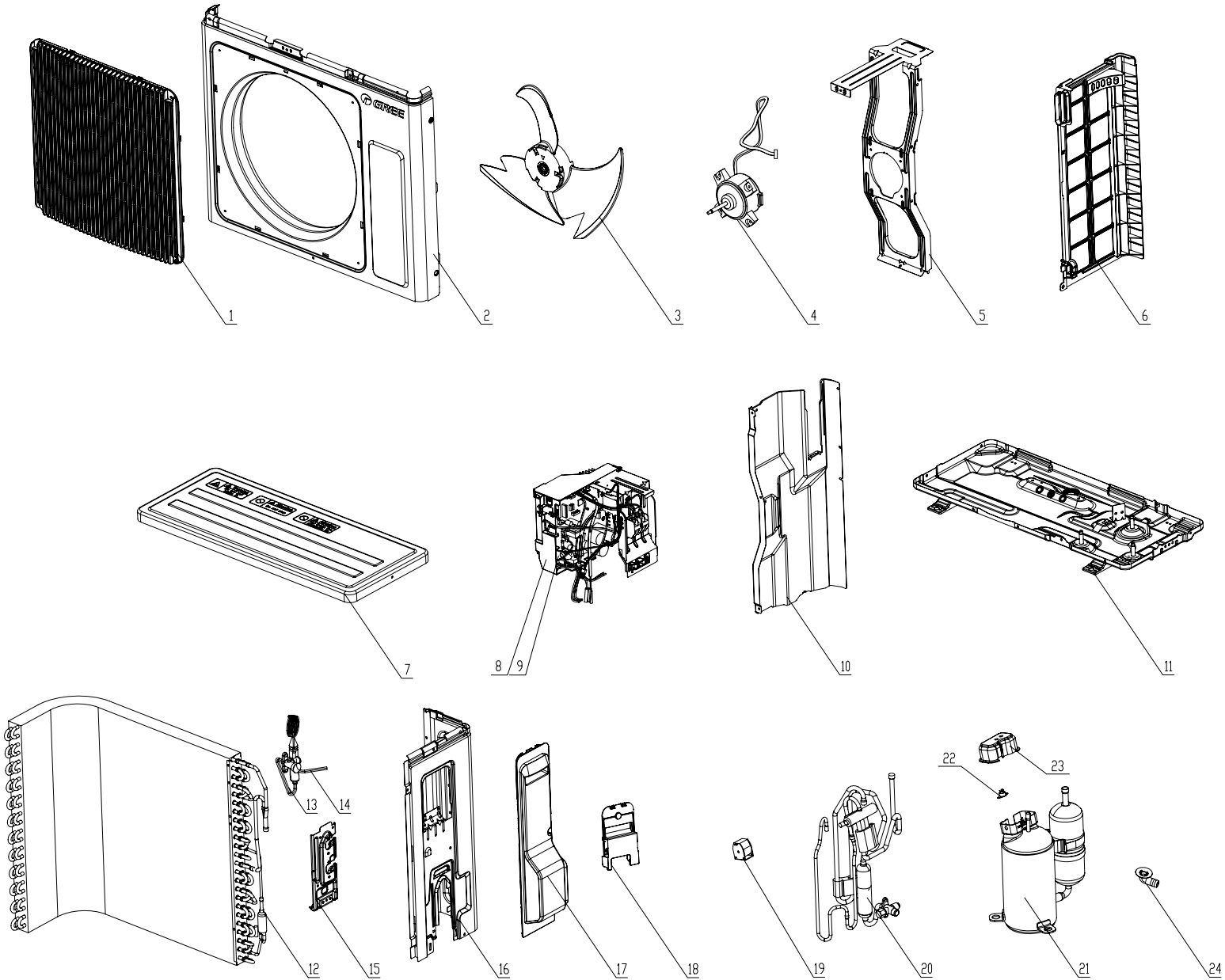

No	Description	Part Code	Note	Qty	Price Code
<b>MODEL: ASH-12AIP PT outdoor</b>					
1	Front Grill	22413017		1	AL
2	Cabinet Sub-assy	0143306101		1	AU
3	Axial Flow Fan Sub-Assy	1033300901		1	AN
4	Fan Motor FW30N	15013073		1	AW
5	Motor Support	01703122		1	AN
6	Left Side Plate	20053001		1	AN
7	Top Cover Sub-Assy	01253071		1	AN
8	Electric Box Assy	02613045		1	BL
9	Main Board W8283AD	30148404		1	BF
10	Clapboard	01233088		1	AL
11	Chassis Sub-assy	02803098P		1	AW
12	Condenser Assy	01113501		1	BP
13	Cut off Valve Assy	07133689		1	AP
14	Capillary Sub-assy	03063984		1	AU
15	Valve Support	01713089		1	AE
16	Right Side Plate Sub-Assy	0130318001		1	AM
17	Handle assy	26233046		1	AF
18	Thermal baffle	26113005		1	AD
19	Magnet Coil	4300040050		1	AM
20	4-Way Valve Assy	03123900		1	AZ
21	Compressor and Fittings QXA-B096zC190	00103869G		1	BN
22	Compressor Overload Protector	00183032		1	AQ
23	Terminal Cap	none		1	
24	Drainage Joint	06123024		1	AD
	Electric Heater(Compressor)	76513004		1	AH
	Reactor	43130184		1	AS
	Temperature Sensor	3900030805		1	AH
	Terminal Board	42010312		1	AE
	Filter Board LB809D	30033081		1	AU
	Electrical Heater (Chassis)	76510004		1	AR
	Silencer	07243045		1	AK
	Compressor Overload Protector(External)	00180030		1	AQ
	Compressor Overload Protector	00183031		1	AQ
	Compressor Gasket	76710287		3	AC
	Gas Valve Assy	07103472		1	AP
	4-Way Valve	430004022		1	AX

**The data are subject to change without notice.**