

USER'S MANUAL

MULTI COMBI SERIES

OUTDOOR UNITS
MC-E36AI, MC-E42AI



User Notice

◆ The total capacity of the indoor units which runs at the same time can not exceed 150% of that of the outdoor units; otherwise, the cooling (heating) effect of each indoor unit would be poor.

◆ Switch the main power on 8 hours before start the unit, helpful for a successful startup.

◆ It is a normal phenomenon that the indoor unit fan will still run for 20~70 seconds after the indoor unit receives the “stop” signal so as to make full use of after-heat for the next operation.

◆ When the running modes of the indoor and outdoor units conflict, it will be indicated on the display of the wired controller in five seconds and then the indoor unit will stop. In this case, they can back to the normal condition by harmonizing their running modes: the cooling mode is compatible with the dehumidifying mode and the fan mode can go with any other mode. If the supply power fails when the unit is running, then the indoor unit will send the “start” signal to the outdoor unit three minutes later after power recovery.

◆ During installation, the communication cable and the power cord must not be twisted together but instead separated with an interval of at least 2cm; otherwise the unit is likely to run abnormally.

◆ Cautions for the Debugging and Maintenance Personnel:

During debugging and maintenance, prior to the startup of the compress make sure the heating belt of the compressor has been energized for at least eight hours! Once the compressor is started, it must be guaranteed that it works continuously for at least 30 minutes, otherwise it would be damaged!

This series outdoor units are matched with the free mach series R410A GMV multi VRF indoor units under the same working conditons exported to European Union.



This product must not be disposed together with the domestic waste. This product has to be disposed at an authorized place for recycling of electrical and electronic appliances.

Thank you for purchasing Sinclair air conditioners. Before use, please read this manual carefully and keep it properly for further reference.

Contents

I Safety Precautions.....	1
II Installation Instructions.....	2
1 Installation Location and Matters Needing Attention.....	2
2 Installation of the Outdoor Unit.....	4
3 Connection between Indoor and Outdoor Units.....	6
4 Refrigerant Charging and Trial Running.....	8
III Working Principles of the Unit.....	11
IV Parts and Components of the Unit.....	12
V Maintenance.....	13
1 Check before the Seasonal Use.....	13
2 Check after the Seasonal Use.....	13
VI Troubleshooting.....	14
1 Please check the following items before contact the maintenance serviceman.....	14
2 The conditions listed below are not classified into errors.....	15
3 Error description.....	15
4 After-Sales Service.....	21
VII Function Description.....	22
VIII Performance Parameters.....	23

I Safety Precautions

Please read this manual carefully before use and operate correctly as instructed in this manual.

Please especially take notice of the following two symbols:



Warning! It indicates improper operation which will lead to human casualty or sever injury.



Caution! It indicates improper operation which will lead to injury or property damage.



Warning!

◆ The installation should be committed to the appointed service center; otherwise it all cause water leakage, electric shock or fire etc.

◆ Please install the unit where is strong enough to withstand the weight of the unit; otherwise, the unit would fall down and cause injury or death.

◆ The drain pipe should be installed as instructed in the manual to guarantee the proper drainage; meanwhile it should be insulated to prevent condensing; otherwise the improper installation would cause water leakage and then wet the household wares in the room.

◆ Do not use or place any inflammable or explosive substance near the unit.

◆ Under the occurrence of an error (like burning smell etc.), please cut off the main power supply of the unit.

◆ Keep good ventilation in the room to avoid oxygen deficit.

◆ Never insert your finger or any other object into the air outlet/inlet grille.

◆ Please take notice of the supporting frame of the unit to see if it is damaged over the long time period of use.

◆ Never refit the unit and contact the sales agent or the professional installation personnel for the repair or relocation of the unit.

◆ Non-professional personnel are prohibited to dismantle the electric box owing to the high voltage of the outdoor unit.

An all-pole disconnection switch having a contact separation of at least 3mm in all poles should be connected in fixed wiring.



Caution!

◆ Before installation, please check if the power supply corresponds with the requirement specified on the nameplate and also check its security.

◆ Before use, please check if the piping and wiring are correct to avoid water leakage, refrigerant leakage, electric shock, fire etc.

◆ The main power supply must be earthed to avoid the hazard of electric shock and never connect this earth wire to the gas pipe, running water pipe, lightning rod or phone cable's earth lead.

◆ Turn off the unit after it runs at least five minutes; otherwise its service life will be shortened.

◆ Do not allow children operate this unit.

◆ Do not operate this unit with wet hands.

◆ Cut off the main power supply prior to the cleaning of the unit or the replacement of the air filter.

◆ When the unit is not to be used for a long time, please cut off the main power supply of the unit.

◆ Do not expose the unit to the moist or corrosive circumstances.

◆ Never step on the unit or place any object on it.

◆ It is suggested to have a power-on test annually.

Installation Instructions

II Installation Instructions

1 Installation Location and Matters Needing Attention

The installation of the unit must comply with the national and local safety regulations. The installation quality directly affects the normal use, so the user should not carry out the installation personally. Instead, the installation and debugging should be done by the professional personnel. Only after that, can the unit be energized.

- a. How to select the installation location for the indoor unit
 - 1) Where there is no direct sunlight.
 - 2) Where the top hanger, ceiling and the building structure are strong enough to withstand the weight of the unit.
 - 3) Where the drain pipe can be easily connected to outside.
 - 4) Where the flow of the air inlet/outlet is not blocked.
 - 5) Where the refrigerant pipe of the indoor unit can be easily led to outside.
 - 6) Where there is no inflammable, explosive substances or their leakage.
 - 7) Where there is no corrosive gas, heavy dust, salt mist, smog or moisture.
- b. How to select the installation location for the outdoor unit
 - 1) The outdoor unit must be installed where the bearing surface is stable and secure enough.
 - 2) The outdoor unit and indoor unit should be placed as close as possible to minimize the length and bends of the refrigerant pipe.
 - 3) Do not install the outdoor unit under the window or between the buildings to prevent the normal running noise entering the room.
 - 4) Where the flow of the air inlet/outlet is not blocked.
 - 5) The outdoor unit should be installed where ventilation is in good condition so that the unit can take in and discharge enough air.
 - 6) Do not install the unit where there are inflammable and explosive substances and where there is heavy dust, salt fog and other severely polluted air.

No air guiding pipe is allowed to be installed at the air inlet/outlet of the outdoor unit. Under the heating mode, the condensate water would drip down from the base frame and would be frozen when the outdoor ambient temperature is lower than 0°C (32 °F) . Besides, the installation of the outdoor unit should not affect the heat radiation of the unit.

⚠ CAUTION !

The unit installed in the following places is likely to run abnormally. If unavoidable, please contact the professional personnel at the appointed service center. ① where is full of oil; ② alkaline soil off the sea; ③ where there is sulfur gas (like sulfur hot spring) ; ④ where there are devices with high frequency (like wireless devices, electric welding devices, or medical equipments); ⑤ special circumstances.

- c. Electric Wiring
 - 1) The installation must be done in accordance with the national wiring regulations.
 - 2) Only the power cord with the rated voltage and exclusive circuit for the air conditioning can be used.
 - 3) Do not pull the power cord by force.
 - 4) The electric installation should be carried out by the professional personnel as instructed by the local laws, regulations and also this manual.
 - 5) The diameter of the power cord should be large enough and once it is damaged it must be replaced by

the dedicated one.

6) The earthing should be reliable and the earth wire should be connected to the dedicated device of the building by the professional personnel. Besides, the air switch coupled with the leakage current protection switch must be equipped, which is of enough capacity and of both magnetic and thermal tripping functions in case of the short circuit and overload.

Table 1

Models	Power Supply	Capacity of the Air Switch	Recommended Cord (pieces× sectional area)
MC-E36AI	220-240V~ 50Hz	32A	6mm ² ×3
MC-E42AI	220-240V~ 50Hz	32A	6mm ² ×3

d. Earthing Requirements

- 1) The air conditioner is classified into the Class I appliances, so its earthing must be reliable.
- 2) The yellow-green line of the air conditioner is the earth line and can not be used for other purpose, cut off or fixed by the self-tapping screw; otherwise it would cause the hazard of electric shock.
- 3) The reliable earth terminal should be provided and the earth wire can not be connected to any of the following places.

- ① . Running water pipe;
- ② . Coal gas pipe;
- ③ . Sewage pipe;
- ④ . Other places where the professional personnel think unreliable.

MC-E42AI

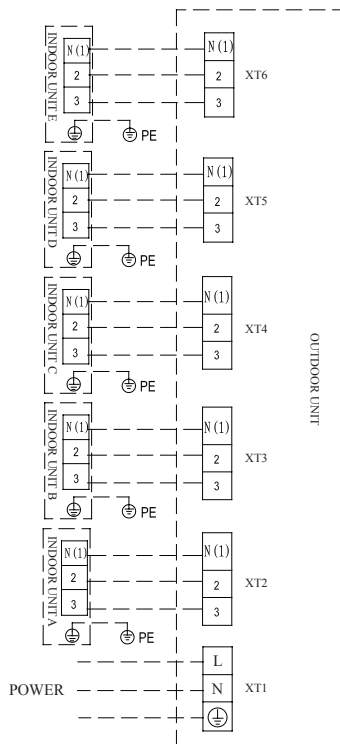

Fig. 1

Installation Instructions

MC-E36AI

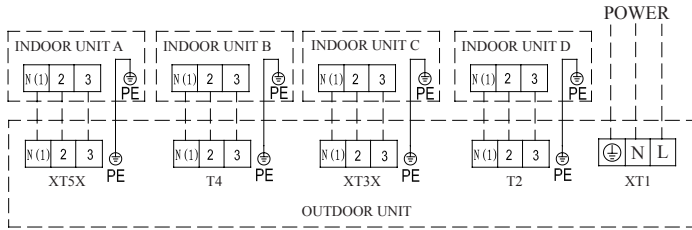

Fig.2

e. Noise Precautions

- 1) The air conditioning unit should be installed where ventilation is in good condition, otherwise the working capability of the unit would be reduced or working noise would be increased.
- 2) The air conditioning unit should be installed on the base frame which is stable and secure enough to withstand the weight of the unit; otherwise it would incur vibration and noise.
- 3) During the installation, a consideration should be taken that the produced hot air or noise should not affect neighbors and surroundings.
- 4) Do not stack obstacles near the air outlet of the outdoor unit; otherwise it would reduce the working capability of the unit or increase the working noise.
- 5) In the event of the occurrence of abnormal noise, please contact the sales agent as soon as possible.

f. Accessories for Installation

Refer to the packing list for the accessories of the indoor and outdoor units respectively.

2 Installation of the Outdoor Unit

a. Precautions for the Installation of the Outdoor Unit

The following rules should be followed when the installation location is being considered so as to let the unit run well enough.

- 1) The discharged air from the outdoor unit won't return back and enough space should be left for maintenance around the unit.
- 2) The installation location should be in good condition so that the unit is able to take in and discharge enough air. Besides, make sure there is no obstacle at the air inlet/outlet of the unit. If there is, remove it.
- 3) The unit must be installed where it is secure enough to support the weight of the unit and capable of reducing to some extent noise and vibration to make sure they do not bother your neighbors.
- 4) The designated lifting hole must be used for lifting the unit and protect the unit carefully during lifting to prevent damaging the metal sheet which would result in rusting in future.
- 5) The unit should be installed where there is as little as direct sunlight.
- 6) The unit must be installed where the rain water and defrosting water can be drained.
- 7) The unit must be installed where the unit won't be covered by the snow and won't be affected by rubbish and oil fog.
- 8) Rubber or spring shock absorbers should be used during the installation of the outdoor unit to meet the noise and vibration requirements.
- 9) The installation dimensions should meet the requirement covered in this manual and the outdoor unit must be fixed securely.
- 10) The installation should be carried out by the professionally skilled personnel.

b. Installation of the Outdoor Unit

- 1) Outline Dimension of the Outdoor Unit.

MC-E36AI

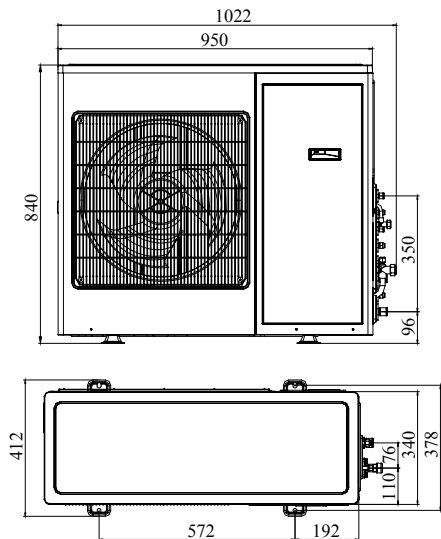

Fig.3

MC-E42AI

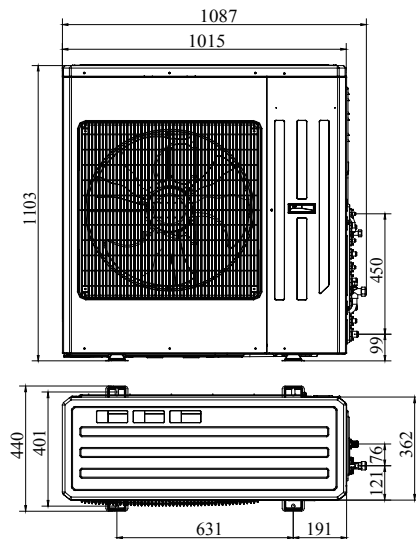

Fig. 4

- 2) During the transportation of the outdoor unit, two lifting ropes long enough must be used in four directions and the separation angle must be less than 40° prevent the center of unit deviating.
- 3) During the installation, M12 screws should be used to fix the support leg and base frame of the unit.
- 4) The unit should be installed on a concrete base frame with a height of 10cm.
- 5) The installation space of the unit should be as required in Fig.5.

Installation Space Requirements of the Outdoor Unit: MC-E36AI, MC-E42AI

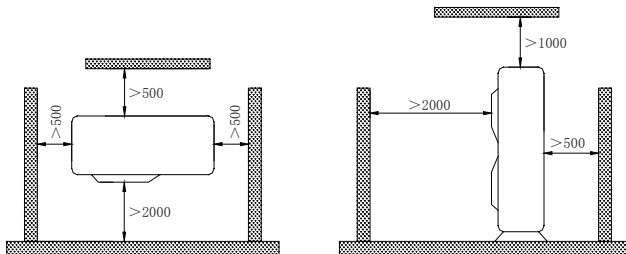

Fig.5

3 Connection between Indoor and Outdoor Units

- a. Wiring of the Power Cord

⚠ CAUTION !

A breaker must be installed, capable of cutting off the power supply for the whole system.

- 1) Open the side plate.
- 2) Let the power cord go through the rubber ring.
- 3) Connect the power card to the terminals “L”, “N” and also the earthing bolt, and then connect the wiring terminals “N(1),2,3” of the indoor unit to those of the outdoor unit correspondingly.
- 4) Fix the power cord with wire clips.

Installation Instructions

b. Capacity Level and Capacity Code of the Indoor and Outdoor Units

Table 2

	Capacity Level	Capacity Code
Indoor Unit	09	25
	12	35
	18	50
	21	60
	24	71
Outdoor Unit	36	100
	42	120

1) The outdoor unit with capacity level 36 can drive up to four sets of indoor units, while the outdoor unit 42 can drive up to five.

2) The sum of the capacity codes of the indoor units should be among 50%-150% of that of the outdoor unit.

c. Allowable Length and Height Fall of the Refrigerant Pipe

Table 3

		Allowable Length		Refrigerant Pipe	
		36	42	36	42
Total Length(m)		70	80	$L_1+L_2+L_3+ L_4$	$L_1+L_2+L_3+ L_4+ L_5$
Max. Length for Single Unit(m)		20	25	L_x	
Max. installation altitude	Outdoor unit and indoor unit	15	15	H1	
	Indoor unit and indoor unit	7.5	7.5	H2	

Table 4: Dimension of the Refrigerant Pipe of the Indoor Unit unit: mm

Capacity Level of the Indoor Unit	Gas Pipe	Liquid Pipe
09,12	φ9.52	φ6.35
18	φ12.7	φ6.35
21,24	φ15.9	φ9.52

d. Piping between the Indoor and Outdoor Units

- 1) Refer to Fig.6 for the moments of torque for tightening screws.
- 2) Let the flare end of the copper pipe point at the screw and then tighten the screw by hand.
- 3) After that, tighten the screw by the torque wrench unit it clatters (as shown in Fig.6).
- 4) The bending degree of the pipe can not be too small; otherwise it will crack. And please use a pipe bender to bend the pipe.
- 5) Wrap the exposed refrigerant pipe and the joints by sponge and then tighten them with the plastic tape.

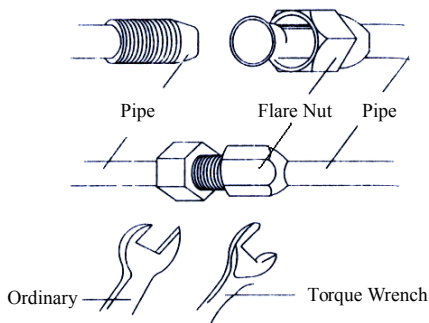

Fig. 6

Table 5: Moments of Torque for Tightening Screws

Diameter	Wall Thickness (mm)	Moment of Torque
$\phi 6.35\text{mm}$	≥ 0.5	15-30(N·m)
$\phi 9.52\text{mm}$	≥ 0.71	30-40(N·m)
$\phi 12.7\text{mm}$	≥ 1	45-50(N·m)
$\phi 15.9\text{mm}$	≥ 1	60-65(N·m)

⚠ CAUTION !

① . During the connection of the indoor unit and the refrigerant pipe, never pull any joints of the indoor unit by force; otherwise the capillary pipe or other pipe may crack, which then would result in leakage.

② . The refrigerant pipe should be supported by brackets, that is, don't let the unit withstand the weight of it.

⚠ CAUTION !

For the **GMV multi VRF system**, each pipe should be labeled to tell which system it belongs to avoid mistaken inaccurate piping.

e. Installation of the Protection Layer of the Refrigerant Pipe

1) The refrigerant pipe should be insulated by the insulating material and plastic tape in order to prevent condensing and leaking.

2) The joints of the indoor unit should be wrapped with the insulating material and no gas is allowed on the joint of the indoor unit, as shown in Fig.7.

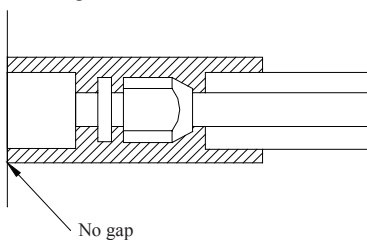

Fig.7

⚠ CAUTION !

After the pipe is protected well enough, never bend it to form a small angle; otherwise it would crack or break.

f. Wrapping the pipe with tape

Installation Instructions

- 1) Bundle the refrigerant pipe and electric wire together with tape, and separate them from the drain pipe to prevent the condensate water overflowing.
- 2) Wrap the pipe from the bottom of the outdoor unit to the top of the pipe where it enters the wall. During the wrapping, the later circle should cover half of the former one.
- 3) Fix the wrapped pipe on the wall with clamps.

⚠ CAUTION !

- ① . Do not wrap the pipe too tightly; otherwise the insulation effect would be weakened. Additionally, make sure the drain hose is separated from the pipe.
- ② . After that, fill the hole on the wall with sealing material to prevent wind and rain coming into the room.

4 Refrigerant Charging and Trial Running

a. Refrigerant Charging

- 1) The refrigerant has been charged into the outdoor unit before shipment, while additional refrigerant still need be charged into the refrigerant pipe during the field installation.
- 2) Check if the liquid valve and the gas valve of the outdoor unit are closed fully.
- 3) As shown in the following figure (Fig.8), expel the gas inside the indoor unit and refrigerant pipe out by the vacuum pump.

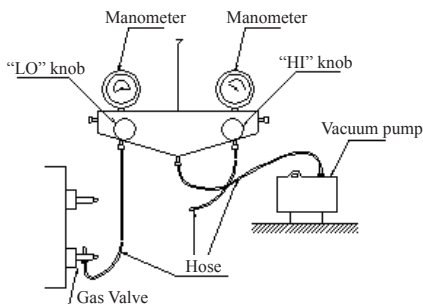

Fig.8

- 4) When the compress is not running, charge the R410A refrigerant into the refrigerant pipe from the liquid valve of the outdoor unit (do not do it from the gas valve).

b. Calculation of the Additional Refrigerant Charge

- 1) Refrigerant Charge in the Outdoor Unit before Shipment

Table 6

Model	MC-E36AI	MC-E42AI
Refrigerant Charge (kg)	3.6	4.8

Notes:

- ① . The refrigerant charge mentioned in the table above is not included those charged additionally in the indoor unit and the refrigerant pipe.
- ② . The amount of the additional refrigerant charge is dependent on the diameter and length of the liquid refrigerant pipe which is decided by the actual yield installation requirement.
- ③ . Record the additional refrigerant charge for future maintenance.

2) Calculation of the Additional Refrigerant Charge

If the total refrigerant pipe length (liquid pipe) is smaller than that listed in the table below, no additional

refrigerant will be charged.

Table 7

Model	Total Liquid Pipe Length (a+b+c+d+e)
MC-E36AI	≤ 40m
MC-E42AI	≤ 50m

Additional Refrigerant Charge₂=∑Extra Liquid Pipe Length×22g/m (liquid pipe 1/4”).

Note: if the total refrigerant pipe length is larger than that listed in the table above, the additional refrigerant for the extra length of the pipe needs to be charged as per 22g/m.

3) Example : MC-E42AI

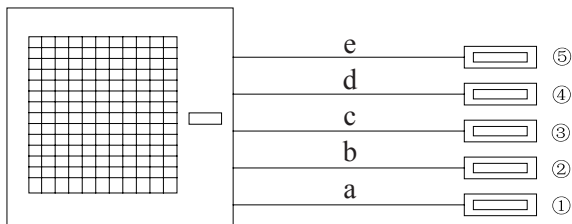

Fig.9

Table 8 Indoor Unit

Serial No.	Model
Indoor Unit ⑤	Ducted Type MC-D09AI
Indoor Unit ④	Ducted Type MC-D09AI
Indoor Unit ③	Ducted Type MC-D09AI
Indoor Unit ②	Ducted Type MC-D09AI
Indoor Unit ①	Ducted Type MC-D09AI

Table 9 Liquid Refrigerant Pipe

Serial No.	e	d	c	b	a
Diameter	φ6.35	φ6.35	φ6.35	φ6.35	φ9.52
Length	20m	20m	15m	5m	5m

The total length of each liquid refrigerant pipe is: e+d+c+b+a=20+20+15+5+5=65m. Thus, the minimum additional refrigerant charge=(65-50)×0.022=0.33kg (Note: no additional refrigerant is needed for the liquid pipe within 50m).

4) Additional Refrigerant Charge Record

Table 10 Indoor Unit

No.	Indoor Unit Model	Additional Refrigerant Charge(kg)
1		
2		
.....		
N		
Total		

Installation Instructions

Table 11 Refrigerant Pipe

Diameter	Total Length(m)	Additional Refrigerant Charge(kg)
Φ15.9		
Φ12.7		
Φ9.52		
Φ6.35		
Total		

c. Items to be checked after the Installation

Table 12

Items to be Checked	Possible Errors	Check Results
Has each part and component the of unit installed securely?	The unit may fall off, vibrate or generate noise.	
Has the gas leakage test been taken?	The cooling (heating) capacity may be poor.	
Is the thermal insulation sufficient?	Dews and water drops may be generated.	
Does the drainage go well?	Dews and water drops may be generated.	
Is the actual power voltage in line with the value marked on the nameplate?	The unit may break down or some components may be burnt out.	
Are the wiring and the piping correct?	The unit may break down or some components may be burnt out.	
Has the unit been earthed reliably?	There may be a danger of electric shock.	
Does the wire meet the regulated requirement?	The unit may break down or the component may be burnt out.	
Is there any obstacle at the air inlet/outlet of the indoor/outdoor unit?	The cooling (heating) capacity may be poor	
Have the length of the refrigerant pipe and the refrigerant charge been recorded?	It may be hard to know the exact refrigerant charge.	

d. Trial Running

1) Check before the Trial Running

- ① . Check if the appearance of the unit and the piping system are damaged during the transportation.
- ② . Check if the wiring terminals of the electronic component are secure.
- ③ . Check if the rotation direction of the fan motor is right.
- ④ . Check if all valves in the system are fully opened.

2) Trial Running

- ① . The trial running should be carried out by the professionally skilled personnel on the premise that all items listed above are in normal conditions.
- ② . Let the unit energized and switch the wired controller or the remoter controller to “ON”.
- ③ . The fan motor and compressor of the outdoor unit will run automatically in one minute.
- ④ . If there is some unusual sound after the compressor is started, turn off the unit for an immediate check.

III Working Principles of the Unit

Schematic Diagram of MULTI COMBI Inverter Heat Pump

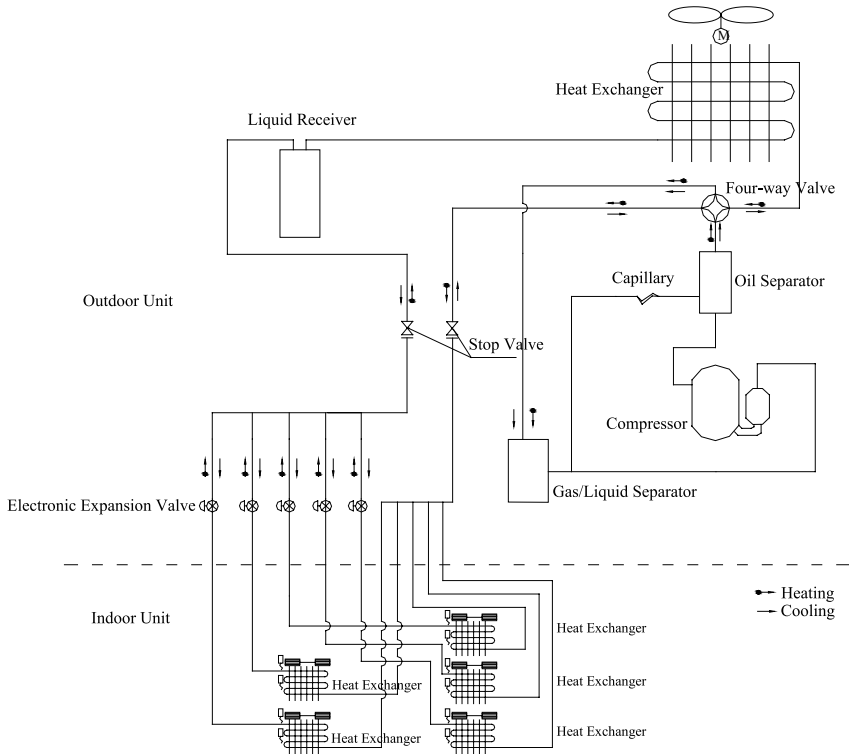

Fig. 10 Schematic Diagram of MULTI COMBI Series Inverter Heat Pump

The outdoor and indoor units start to work once the power is switched on. During the cooling operation, the low temperature, low pressure refrigerant gas from the heat exchanger of each indoor unit gets together and then is taken into the compressor to be compressed into high temperature, high pressure gas, which will soon go to the heat exchanger of the outdoor unit to exchange heat with the outdoor air and then is turned into refrigerant liquid. After passing through the throttling device, the temperature and pressure of the refrigerant liquid will further decrease and then go the main valve. After that, it will be divided and go to the heat exchanger of each indoor unit to exchange heat with the air which needs to be conditioned. Consequently, the refrigerant liquid become low temperature, low pressure refrigerant gas again. Such a refrigeration cycle goes round and round to achieve the desired refrigeration purpose. During the heating operation, the four-way valve is involved to make the refrigeration cycle run reversely. The refrigerant radiates heat in the heat exchanger of the indoor unit (so do the electric heating devices) and absorb heat in the heat exchanger of the outdoor unit for a heat pump heating cycle so as to achieve the desired heating purpose.

IV Parts and Components of the Unit

System Structure

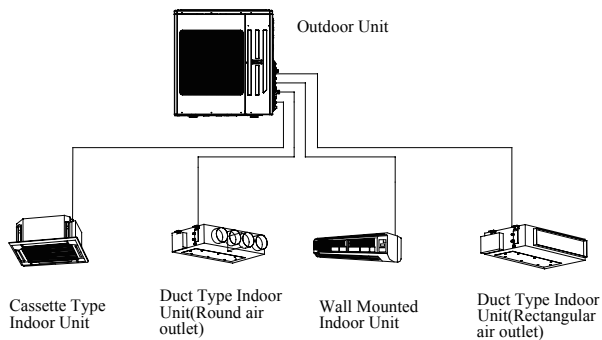

Fig. 11

For the MULTI COMBI series DC inverter air conditioning system, one outdoor unit is able to drive up to five indoor units which can be cassette type, duct type, wall-mounted or floor ceiling type. Among them, the cassette type and the wall-mounted indoor units should be controlled by the remote controller, while the ducted type can be controlled by either the remote controller or the wired controller. The outdoor unit will run as long as any one indoor unit receives the running command, and all indoor units stop once the outdoor unit is turned off.

V Maintenance

WARNING !

①. The unit can only be cleaned after the unit is turned off and the main power is cut off; otherwise it would cause an electric shock hazard.

②. Do not dampen the air conditioner, as it would cause an electric shock hazard and never rinse the unit with water in any event.

CAUTION !

①. Volatile liquid, like thinner, gasoline etc would damage the appearance of the air conditioning unit. (Only use the soft dry cloth or the wet cloth with neutral detergent clean the outer shell of the air conditioning unit)

②. Do not clean the outer shell of the air conditioning unit with more than 45 °C hot water to prevent discoloration or deformation.

③. Do not dry the air filter screen of the indoor unit on the fire to prevent inflammation or deformation.

1 Check before the Seasonal Use

1) Check if the inlet/outlet of the indoor/outdoor unit is clogged.

2) Check if the earth lead is earthed reliably.

3) Check if the batteries of the remote controller are replaced.

4) Check if the air filter screen is installed improperly.

5) Check if the installation of the outdoor is secure. If there is something abnormal, please contact the appointed service center.

6) When restarting the unit which is not used for a long time, switch on the main power supply eight hours ahead, helpful for a successful startup.

2 Check after the Seasonal Use

1) Clean the filter screen and body of the indoor and outdoor units.

2) Cut off the main power supply of the air conditioning system.

3) Remove the dust and the foreign matters of the outdoor unit.

4) In the event of rusting, use the anti-rust paint to stop spreading of rust.

Refer to the *Installation and Operation Manual* of each indoor unit respectively for detailed maintenance.

Troubleshooting

VI Troubleshooting

WARNING !

① . In the event of abnormal conditions (like, stinky smell), please shut off the main power supply immediately and then contact the appointed service center; otherwise the continuous abnormal running would damage the air conditioning unit and also would cause electric shock or fire hazard etc.

② . Do not repair the air conditioning personally but instead contact the professionally skilled personnel at the appointed service center, as the incorrect repair would cause electric shock or fire hazard etc.

1 Please check the following items before contact the maintenance serviceman.

Table 13

Conditions	Causes	Corrective Actions
The unit does not run	Broken fuse or opened breaker	Change the fuse or close the breaker
	Power off	Restart the unit when power on
	Loosened power supply plug.	Plug the power supply properly.
	Insufficient batteries voltage of the remote controller	Change new batteries
	Remoter controller out of the control scope	Keep the control distance within 8 meters.
The unit stops soon after it starts	Clogged inlet/outlet of the indoor/outdoor unit	Clear the obstacle
Cooling/Heating is abnormal	Clogged inlet/outlet of the indoor/outdoor unit	Clear the obstacle
	Improperly set temperature	Adjust the setting of the remote or wired controller.
	Too low set fan speed	Adjust the setting of the remote or wired controller.
	Incorrect air direction	Adjust the setting of the remote or wired controller.
	Opened door and window	Close the door and window
	Direct sunlight	Hang a curtain or blinds over the window.
	Too much people in the room	
	Too much heat sources in the room	Reduce the heat sources
	Dirty filter screen	Clean the filter screen

Note:

If the air conditioner still runs abnormally after the above check and handling, please contact the maintenance serviceman at the local appointed service center and also give a description of the error occurred as well as the model of the unit.

2 The conditions listed below are not classified into errors

Table 14

Conditions		Causes
The unit does not run	When restart the unit soon after it is stopped.	The overload protection switch of the unit let the startup delayed for three minutes.
	As soon as power is on.	The unit will stand by for approximate one minute.
The unit blows out mist	When the cooling operation starts.	The hi-humidity air indoor is cooled quickly.
The unit generates noise	The unit “clatters” as soon as it starts running.	It is the sound generated during the initialization of the electronic expansion valve.
	The unit “swishes” during the cooling operation.	It is the sound when the refrigerant gas runs inside the unit.
	The unit “swishes” when it is started or stopped.	It is the sound when the refrigerant gas stops running.
	The unit “swishes” when in it is and after the running.	It is the sound when the draining system is operating.
	The unit “squeaks” when it is in and after the running.	It is the sound of friction generated by the skin plate etc which swells due to the temperature change.
The unit blows out dust.	When the unit restarts after it is not used for a long time.	The dust inside the unit is blown out again.
The unit emits odors.	When the unit is running.	The odors absorbed in are blown out again.

3 Error description

If some error occurs when the unit is running, the error code will be displayed on the wired controller and the main board  of the outdoor unit. See the table before for more details about the meaning of each error.

Table 15

Residential AC Errors	Commerical AC Errors	Outdoor Unit "88" Display	Indicating Lamp			Lamp Panel "88" Display (Floor Ceiling Type)	Wired Controller Display
			Running	Cooling	Heating		
/	Defrosting mode 1	08	/	/	/	/	/
/	Defrosting mode 2	0A	/	/	/	/	/
/	heating overload protection	0C	Flash 3 times	Flash 3 times	Flash 3 times	/	oE
/	Normal running	ON	/	/	/	/	/
Short/open circuit of the liquid valve temperature sensor	Short/open circuit of the liquid valve temperature sensor	Shown as Table 16	/	Flash 19 times	/	b5	b5
Short/open circuit of the gas valve temperature sensor	Short/open circuit of the gas valve temperature sensor	Shown as Table 16	/	Flash 22 times	/	b7	b7

Troubleshooting

Refrigerant insufficiency or blockage protection (available for the residential outdoor unit)	Refrigerant insufficiency or blockage protection (available for the residential outdoor unit)	F0	/	Flash 10 times	/	oE	oE
Short/open circuit of the indoor ambient temperature sensor	Short/open circuit of the indoor ambient temperature sensor	Shown as Table 16	/	Flash once	/	F1	F1
Short/open circuit of the indoor evaporator	Short/open circuit of the indoor evaporator	Shown as Table 16	/	Flash twice	/	F2	F2
Short/open circuit of the of the outdoor ambient temperature sensor	Short/open circuit of the of the outdoor ambient temperature sensor	F3	/	Flash 3 times	/	F3	F3
Short/open circuit of the temperature sensor at the midway of the condenser coil (for the commercial unit)	Short/open circuit of the temperature sensor at the midway of the condenser coil (for the commercial unit)	F4	/	Flash 4 times	/	F4	F4
Short/open circuit of the outdoor discharge temperature sensor	Short/open circuit of the outdoor discharge temperature sensor	F5	/	Flash 5 times	/	F5	F5
Oil returning in cooling	Oil returning in cooling	F7	/	/	/	/	/
System high pressure protection	System high pressure protection	E1	Flash once	/	/	E1	E1
Anti-freezing protection	Anti-freezing protection	E2	Flash twice	/	/	E2	E2
System low pressure protection (reserved)	System low pressure protection	E3	Flash 3 times	/	/	E3	E3
Compressor discharge high temperature protection	Compressor discharge high temperature protection	E4	Flash 4 times	/	/	E4	E4
Whole unit over-current protection	Whole unit over-current protection	E5	Flash 3 times	Flash 3 times	Flash 3 times	oE	oE
Communication error between the indoor and outdoor units	Communication error between the indoor and outdoor units	Shown as Table 16	Flash 6 times	/	/	E6	E6

Mode conflict	Mode conflict	Shown as Table 16	Flash 7 times	/	/	E7	E7
Overload protection	Overload protection	E8	Flash 3 times	Flash 3 times	Flash 3 times	oE	oE
Anti cold blow protection	/	E9	/	/	/	/	/
/	Indoor unit water overflow error		/	Flash	Flash	E9	E9
Trial run/trial operation	Trial run/trial operation	dd	Quick flash	Quick flash	Quick flash	dd	dd
Refrigerant recovery mode	Refrigerant recovery mode	Fo	Quick flash	Quick flash	/	Fo	Fo
Drive module resetting (for the commercial unit)	IPM Drive module resetting	P0	Flash 3 times	Flash 3 times	Flash 3 times	oE	oE
Min. cooling/heating (capability test code)	Cooling IPLV test	P0	/	Quick flash	/	P0	P0
	Cooling IPLV test		/	/	Quick flash	P0	
Mid. Cooling/heating (capability test code)	Cooling level AA performance test	P3	/	Quick flash	/	P3	P3
	Level AA cooling performance test		/	/	Quick flash	P3	
Phase over-current protection	Compressor over-current protection	P5	Flash 3 times	Flash 3 times	Flash 3 times	oE	oE
Drive board communication error(for the commercial unit)	Communication error between the inverter driver to the main controller	P6	Flash 3 times	Flash 3 times	Flash 3 times	oE	oE
Short/open circuit of the of the module temperature sensor	Short/open circuit of the of the module temperature sensor	P7	Flash 3 times	Flash 3 times	Flash 3 times	oE	oE
Module temperature protection	Module temperature protection	P8	Flash 3 times	Flash 3 times	Flash 3 times	oE	oE
AC contact protection (for the commercial unit)	AC contact protection	P9	Flash 3 times	Flash 3 times	Flash 3 times	oE	oE
Circuit sensor error	Circuit sensor error	Pc	Flash 3 times	Flash 3 times	Flash 3 times	oE	oE
Transducer connection protection (for the commercial unit)	Transducer connection protection	Pd	Flash 3 times	Flash 3 times	Flash 3 times	oE	oE
AC current protection(input side)	AC current protection(input side)	PA	Flash 3 times	Flash 3 times	Flash 3 times	oE	oE
Temperature drift protection (for the commercial unit)	Temperature drift protection	PE	Flash 3 times	Flash 3 times	Flash 3 times	oE	oE

Troubleshooting

Drive board ambient temperature sensor error (for the commercial unit)	Drive board ambient temperature sensor error	PF	Flash 3 times	Flash 3 times	Flash 3 times	oE	oE
DC link high voltage protection	DC link low voltage protection	PL	Flash 3 times	Flash 3 times	Flash 3 times	oE	oE
DC link low voltage protection	DC link high voltage protection	PH	Flash 3 times	Flash 3 times	Flash 3 times	oE	oE
/	Abnormal AC input voltage	PP	Flash 3 times	Flash 3 times	Flash 3 times	oE	oE
Capacitor charging error	Capacitor charging error	PU	Flash 3 times	Flash 3 times	Flash 3 times	oE	oE
Jumper terminal error protection	Jumper terminal error protection	C5	Flash 3 times	Flash 3 times	Flash 3 times	oE	oE
Defrosting or oil returning in heating	Defrosting or oil returning in heating	H1	/	/	Flash once	H1	Defrosting symbol displayed
/	Forcible defrosting	H1	Quick flash	/	/	H1	H1
Compressor thermal overload protection.	Compressor overload protection.	H3	Flash 3 times	Flash 3 times	Flash 3 times	oE	oE
Module current protection (namely IPM protection)	IPM Module current protection	H5	Flash 3 times	Flash 3 times	Flash 3 times	oE	oE
Compressor desynchronizing	Compressor desynchronizing	H7	Flash 3 times	Flash 3 times	Flash 3 times	oE	oE
PFC Protection	PFC Protection	HC	Flash 3 times	Flash 3 times	Flash 3 times	oE	oE
Too high power protection (available for the residential outdoor unit)	Too high power protection (available for the residential outdoor unit)	L9	Flash 20 times	/	/	oE	oE
Compressor startup failure	Compressor startup failure	Lc	Flash 3 times	Flash 3 times	Flash 3 times	oE	oE
Compressor phase failure/reverse protection	Compressor phase failure/reverse protection	Ld	Flash 3 times	Flash 3 times	Flash 3 times	oE	oE
Compressor rotation failure(for the commercial unit)	Compressor rotation failure(for the commercial unit)	LE	Flash 3 times	Flash 3 times	Flash 3 times	oE	oE
Over speed (for the commercial unit)	Over speed	LF	Flash 3 times	Flash 3 times	Flash 3 times	oE	oE

Short/open circuit of the temperature sensor at the inlet of the condenser coil (for the commercial unit)	/	A5	/	/	/	/	/
Short/open circuit of the temperature sensor at the outlet of the condenser coil (for the commercial unit)	/	A7	/	/	/	/	/
Memory card error	/	EE	/	/	/	/	/
Frequency limitation/ degradation for module circuit protection (for phase circuit)	/	En	/	/	/	/	/
Frequency limitation/ degradation for module temperature protection	/	EU	/	/	/	/	/
Frequency limitation/ degradation for overload	/	F6	/	Flash 6 times	/	/	/
Frequency limitation / degradation for circuit protection of the whole unit	/	F8	/	Flash 8 times	/	/	/
Frequency limitation/ degradation for module circuit protection (for phase circuit)	/	F9	/	Flash 9 times	/	/	/
Frequency limitation/ degradation for anti-freezing protection	/	FH	/	Flash 2 times	Flash 2 times	/	/
No indoor fan motor	/	H6	Flash 11 times	/	/	/	/
Compressor demagnetizing protection	/	HE	/	/	Flash 14 times	/	/
Indoor and outdoor units unmatched	/	LP	Flash 19 times	/	/	/	/

Troubleshooting

Compressor phase circuit detection error	/	U1	/	/	Flash 12 times	/	/
DC link voltage drop error	/	U3	/	/	Flash 20 times	/	/
Zero detection circuit error	/	U8	Flash 17 times	/	/	/	/
Nominal cooling/heating (capability test code)	/	P1	/	/	/	/	/
Max. cooling/heating (capability test code)	/	P2	/	/	/	/	/

The words in gray means the corresponding function is unavailable.

Table 16

Error Code	Error Description	Error Code	Error Description	Error Code	Error Description
13	Unit A indoor unit pipe outlet temperature sensor error	23	Unit B indoor unit pipe outlet temperature sensor error	33	Unit C indoor unit pipe outlet temperature sensor error
14	Unit A indoor pipe inlet temperature sensor error	24	Unit B indoor pipe inlet temperature sensor error	34	Unit C indoor pipe inlet temperature sensor error
15	Unit A indoor ambient temperature sensor error	25	Unit B indoor ambient temperature sensor error	35	Unit C indoor ambient temperature sensor error
16	Unit A mode conflict	26	Unit B mode conflict	36	Unit C mode conflict
17	Unit A anti-freezing protection	27	Unit B anti-freezing protection	37	Unit C anti-freezing protection
41	Unit D communication error	46	Unit D mode conflict	54	Unit E indoor pipe inlet temperature sensor error
42	Unit D indoor pipe midway temperature sensor error	47	Unit D anti-freezing protection	55	Unit E indoor ambient temperature sensor error
43	Unit D indoor unit pipe outlet temperature sensor error	51	Unit E communication error	56	Unit E mode conflict
44	Unit D indoor pipe inlet temperature sensor error	52	Unit E indoor pipe midway temperature sensor error	57	Unit E anti-freezing protection
45	Unit D indoor ambient temperature sensor error	53	Unit E indoor unit pipe outlet temperature sensor error	C5	Jumper terminal error

Table 17 Error description of outdoor refrigerant pipe detection function

Wiring error or component error	Unit which is detecting	Unit which isn't detecting
5E	01	**
5E	02	**
5E	03	**
5E	04	**
5E	05	**
Indoor unit gas pipe connection error or component error	Unit which is detecting	--
5P	01	--
5P	02	--
5P	03	--
5P	04	--
5P	05	--

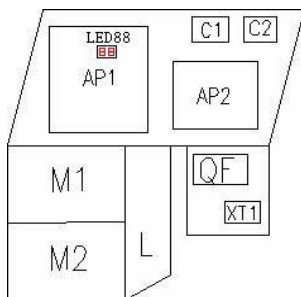

Fig.12 Outdoor Unit: MC-E36AI, MC-E42AI

(Note: Refer to the real products for the exact position of each component.)

Once errors are displayed on the controller, please shut off the air conditioning unit and contact the professionally skilled personnel for troubleshooting.

4 After-Sales Service

If there is any quality or other issue, please contact the after-sales service center.

Function Description

VII Function Description

Refrigerant Recovery

The refrigerant can be recovered from either the indoor unit or the outdoor unit.

From the outdoor unit: it is available to recover the refrigerant from the outdoor unit by pressing “SW3” for a long time period.

From the indoor unit: when the unit is powered on and runs under the COOL mode, it is available within five minute to go the refrigerant recovery mode by pressing three times the “LIGHT” button on the wireless controller in three seconds with “F0” displayed.

How to quit the refrigerant recovery:

When the refrigerant recovery has started, it will quit when the “SW3” is pressed down for a long time period or there is a signal from the wireless controller or it has run for ten minutes.

Forcible Defrosting

How to activate this function: when indoor unit runs under the heating mode and at 16℃ , it will activate the forcible defrosting by pressing the “+” and “-” buttons alternately three times in five seconds.

How to quit this function: the function will quit when the mode of indoor units conflicts.

Switchover of the Defrosting Modes

Under the unit is under the “Off” status, if “H1” is not displayed on the wireless controller, then the unit will go to the defrosting mode 1 when it is turned on through the wireless controller.

Under the unit is under the “Off” status, if “H1” is displayed on the wireless controller, the unit will go the defrosting mode 2 when it is turned on through the wireless controller.

Under the unit is under the “Off” status, it is available to switch over the defrosting mode 1 and defrosting mode 2 by pressing the “Mode” and “Blow” buttons simultaneously.

VIII Performance Parameters

Rated Working Conditions of the Air Conditioning Unit

Table 18 Working Temperature Range

	Indoor side state		Outdoor side stae	
	Dry bulb temp. °C	Wet bulb temp. °C	Dry bulb temp. °C	Wet bulb temp. °C
Rated Cooling	27	19	35	24
Max. cooling	32	23	48	26
Min. cooling	21	15	18	—
Rated Heating	20	15	7	6
Max. heating	27	—	24	18
Min. heating	20	15	— 15	— 16

Notes:

- ① . The heating/cooling capacity and noise listed below are all measured before the shipment.
- ② . All parameters listed below are measured under the standard working conditions. If there is any change, the parameters marked on the nameplate always prevail.
- ③ . The heating capacity of the indoor unit just involves that of the heat pump but apart from that of the auxiliary electric heater.