

TECHNICAL CATALOGUE COMMERCIAL SYSTEMS 2024

- OUTDOOR UNITS SDV6
- OUTDOOR UNITS SDV5
- OUTDOOR UNITS SDV5-3P
- SDB SDV5-3P
- INDOOR UNITS SDV6
- CONTROLLERS
- BMS SYSTEMS
- MINI CHILLERS
- MODULAR CHILLERS
- FAN COIL UNITS

CONTAIN

SMALL INDIVIDUAL SIDE DISCHARGE AIR OUTDOOR UNITS SDV6 R32	2
SMALL INDIVIDUAL SIDE DISCHARGE AIR OUTDOOR UNITS SDV6 R410A	5
INDIVIDUAL SIDE DISCHARGE AIR OUTDOOR UNITS SDV5	8
INDIVIDUAL SIDE DISCHARGE AIR OUTDOOR UNITS SDV6	10
TOP AIR DISCHARGE INDIVIDUAL OUTDOOR UNITS SDV6	12
TOP AIR DISCHARGE MODULAR OUTDOOR UNITS SDV6	12
OUTDOOR UNITS SDV5-3P	16
SDB SDV5-3P	20
INDOOR UNITS SDV6	22
AHU KIT	34
CONTROLLERS	38
BMS SYSTEMS	39
ELECTRICAL CONNECTION	40
REFNETS	43
ERROR CODES SDV6	44
MINI CHILLERS	46
MODULAR CHILLERS	50
FAN COIL UNITS	56

OUTDOOR UNITS

SDV6 SMALL INDIVIDUAL SIDE DISCHARGE R32

MODEL			SDV6-E80BS	SDV6-E100BS	SDV6-E120BS	SDV6-E140BS	SDV6-E160BS
Horse power (HP)		-	2,5	3,5	4,4	5	6
Power		phase / Hz / V	1 ~ / 50 / 220-240	1 ~ / 50 / 220-240	1 ~ / 50 / 220-240	1 ~ / 50 / 220-240	1 ~ / 50 / 220-240
Cooling capacity		kW	7,2	9	12,3	14	15,5
Cooling input power		kW	1,95	2,77	3,73	4,67	5,34
EER		-	3,69	3,25	3,30	3,00	2,90
SEER		-	5,80	5,70	7,80	7,40	7,35
$\eta_{s,c}$		%	-	-	309	293	291
Heating capacity (max.)		kW	9	10,8	14	16	17,5
Heating input power (max.)		kW	2,5	3,18	3,59	4,21	4,73
COP		-	3,60	3,40	3,90	3,80	3,70
SCOP		-	3,80	3,80	4,90	4,80	4,80
$\eta_{s,h}$		%	-	-	193	189	189
Combination of indoor units		-	50-160% of outdoor unit capacity				
Number of indoor units		-	5	6	8	10	11
Compressor		Type	DC inverter	DC inverter	DC inverter	DC inverter	DC inverter
		Qty	1	1	1	1	1
		Oil	FVC68D	FVC68D	FVC68D	FVC68D	FVC68D
Operating range-cooling		°C	-15-52	-15-52	-15-52	-15-52	-15-52
Operating range-heating		°C	-20~16,5 (WB)	-20~16,5 (WB)	-20~16,5 (WB)	-20~16,5 (WB)	-20~16,5 (WB)
Sound pressure level		dB(A)	53	53	53	56	56
Sound power level		dB(A)	68	69	69	71	72
Airflow		m ³ /h	-	-	-	-	-
Net weight		kg	77	77	94	94	94
Gross weight		kg	88	88	105	105	105
Net dimensions	w x h x d	mm	1038x864x409	1038x864x409	1038x864x409	1038x864x409	1038x864x409
Packing dimensions	w x h x d	mm	1120x980x560	1120x980x560	1120x980x560	1120x980x560	1120x980x560
Refrigerant		type	R32	R32	R32	R32	R32
		kg	2	2	2,85	2,85	2,85
		t eq. CO ₂	1,35	1,35	1,59	1,59	1,59
Vertical pipe length *		m	30 / 20	30 / 20	50 / 40	50 / 40	50 / 40
Pipe length from 1. branch		m	30	30	40	40	40
Equivalent pipe length		m	60	60	120	120	120
Total pipe length		m	150	150	300	300	300
Pipe diameter - liquid side		mm	9,5	9,5	9,5	9,5	9,5
Pipe diameter - gas side		mm	15,9	15,9	15,9	15,9	15,9
ADDITIONAL TECHNICAL INFORMATION							
Screw holes distance of OD	w x d	mm	656x463	656x463	656x463	656x463	656x463
Communication cable		mm ²	3x0,75 shielded in case mixed IDU SDV5 and SDV6 or 2x0,75 in case only IDU SDV6 (more than 10pcs IDU SDV6 require reperature SDV6-RPT in case separate power supply of each IDU SDV6)				
Recommended power cable		mm ²	3x6,0	3x6,0	3x10,0	3x16,0	3x16,0
Recommended air switch		A	B25	B25	B32	B40	B40
EQUIPMENT							
Crancase heater			yes	yes	yes	yes	yes
Drain pipe connector			yes	yes	yes	yes	yes
Alarm signal			yes (dry-contact)	yes (dry-contact)	yes (dry-contact)	yes (dry-contact)	yes (dry-contact)
ON/OFF signal			yes (dry-contact)	yes (dry-contact)	yes (dry-contact)	yes (dry-contact)	yes (dry-contact)
Defrost signal			yes (dry-contact)	yes (dry-contact)	yes (dry-contact)	yes (dry-contact)	yes (dry-contact)
OPTIONAL ACCESSORIES							
Central controller with weekly timer			CCM-180A**				
Central controller with LAN access			CCM-270A**, SCC-61, SDV6-CLOUD				
BMS gateway			SDV5-MOD**, SDV5-BAC**, SDV6-MOD, SDV6-BAC				
Extension kit (2xXYE)			SDV5-EK**, SDV6-EK				

* Outdoor unit top max. / bottom max.

** Require to set on ODU protocol SDV5.

The specification of products is subject to change based on further development of the units by the producer and can be changed without prior notice. Refer to rating label.

R32 (100% HFC-32), GWP of refrigerant used: 675.

Contains fluorinated greenhouse gases covered by the Kyoto Protocol.

Conditions under which has been performed measurements of technical parameters see last page.

Electrical connection scheme for power supply, communication and controller connection see page 42.

OUTDOOR UNITS

SDV6 SMALL INDIVIDUAL SIDE DISCHARGE R32

MODEL			SDV6-E180BS	SDV6-E120BS-3	SDV6-E140BS-3	SDV6-E160BS-3	SDV6-E180BS-3
Horse power (HP)		-	6,4	4,4	5	6	6,4
Power		phase / Hz / V	1 ~ / 50 / 220-240	3 ~ / 50 / 380-415	3 ~ / 50 / 380-415	3 ~ / 50 / 380-415	3 ~ / 50 / 380-415
Cooling capacity		kW	17,5	12,3	14	15,5	17,5
Cooling input power		kW	6,46	3,37	4,67	5,34	6,46
EER		-	2,71	3,65	3,00	2,90	2,71
SEER		-	7,10	7,80	7,40	7,35	7,10
$\eta_{s,c}$		%	281	309	293	291	281
Heating capacity (max.)		kW	19,5	14	16	17,5	19,5
Heating input power (max.)		kW	5,57	3,59	4,21	4,73	5,57
COP		-	3,50	3,90	3,80	3,70	3,50
SCOP		-	4,80	4,90	4,80	4,80	4,80
$\eta_{s,h}$		%	189	193	189	189	189
Combination of indoor units		-	50-160% of outdoor unit capacity				
Number of indoor units		-	12	8	10	11	12
Compressor		Type	DC inverter	DC inverter	DC inverter	DC inverter	DC inverter
		Qty	1	1	1	1	1
		Oil	FVC68D	FVC68D	FVC68D	FVC68D	FVC68D
Operating range-cooling		°C	-15-52	-15-52	-15-52	-15-52	-15-52
Operating range-heating		°C	-20~16,5 (WB)	-20~16,5 (WB)	-20~16,5 (WB)	-20~16,5 (WB)	-20~16,5 (WB)
Sound pressure level		dB(A)	58	55	56	56	58
Sound power level		dB(A)	73	72	73	74	78
Airflow		m ³ /h	-	-	-	-	-
Net weight		kg	94	110	110	110	110
Gross weight		kg	205	121	121	121	121
Net dimensions	w x h x d	mm	1038x864x409	1038x864x409	1038x864x409	1038x864x409	1038x864x409
Packing dimensions	w x h x d	mm	1120x980x560	1120x980x560	1120x980x560	1120x980x560	1120x980x560
Refrigerant		type	R32	R32	R32	R32	R32
		kg	2,85	2,85	2,85	2,85	2,85
		t eq. CO ₂	1,59	1,59	1,59	1,59	1,59
Vertical pipe length *		m	50 / 40	50 / 40	50 / 40	50 / 40	50 / 40
Pipe length from 1. branch		m	40	40	40	40	40
Equivalent pipe length		m	120	120	120	120	120
Total pipe length		m	300	300	300	300	300
Pipe diameter - liquid side		mm	9,5	9,5	9,5	9,5	9,5
Pipe diameter - gas side		mm	19,1	15,9	15,9	15,9	19,1
ADDITIONAL TECHNICAL INFORMATION							
Screw holes distance of OD	w x d	mm	656x463	656x463	656x463	656x463	656x463
Communication cable		mm ²	3x0,75 shielded in case mixed IDU SDV5 and SDV6 or 2x0,75 in case only IDU SDV6 (more than 10pcs IDU SDV6 require reperature SDV6-RPT in case separate power supply of each IDU SDV6)				
Recommended power cable		mm ²	3x16,0	5x4,0	5x4,0	5x4,0	5x4,0
Recommended air switch		A	B40	B20	B20	B20	B20
EQUIPMENT							
Crancase heater			yes	yes	yes	yes	yes
Drain pipe connector			yes	yes	yes	yes	yes
Alarm signal			yes (dry-contact)	yes (dry-contact)	yes (dry-contact)	yes (dry-contact)	yes (dry-contact)
ON/OFF signal			yes (dry-contact)	yes (dry-contact)	yes (dry-contact)	yes (dry-contact)	yes (dry-contact)
Defrost signal			yes (dry-contact)	yes (dry-contact)	yes (dry-contact)	yes (dry-contact)	yes (dry-contact)
OPTIONAL ACCESSORIES							
Central controller with weekly timer			CCM-180A**				
Central controller with LAN access			CCM-270A**, SCC-G1, SDV6-CLOUD				
BMS gateway			SDV5-MOD**, SDV5-BAC**, SDV6-MOD, SDV6-BAC				
Extension kit (2xXYE)			SDV5-EK**, SDV6-EK				

* Outdoor unit top max. / bottom max.

** Require to set on ODU protocol SDV5.

The specification of products is subject to change based on further development of the units by the producer and can be changed without prior notice. Refer to rating label.

R32 (100% HFC-32), GWP of refrigerant used: 675.

Contains fluorinated greenhouse gases covered by the Kyoto Protocol.

Conditions under which has been performed measurements of technical parameters see last page.

Electrical connection scheme for power supply, communication and controller connection see page 42.

APPEARANCE AND DIMENSIONS OF OUTDOOR UNIT

SDV6 SMALL INDIVIDUAL SIDE DISCHARGE R32

SDV6-E80-180BS/BS-3

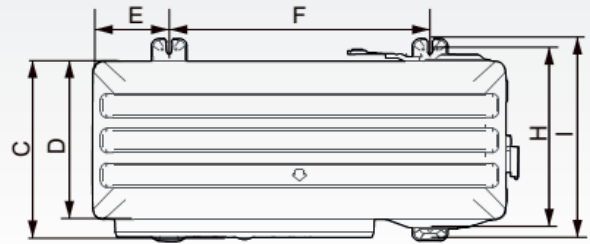
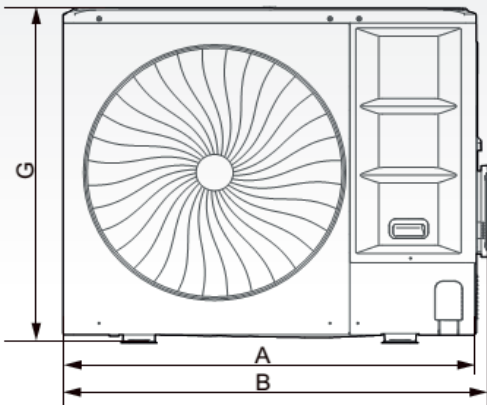

Model	SDV6-E80-180BS/BS-3
A (mm)	1038
B (mm)	1073
C (mm)	454
D (mm)	409
E (mm)	191
F (mm)	656
G (mm)	864
H (mm)	463
I (mm)	523

ALLOWED LENGTH AND DROP HEIGHT OF CONNECTION (See installation manual)

Additional refrigerant:

Calculate the added refrigerant according to the diameter and the length of the liquid side pipe of the outdoor unit/indoor unit connection.

When the outdoor unit connects 1 meter.

ADDITIONAL REFRIGERANT

Liquid side piping (mm)	Additional ref. charge R32 per meter of equivalent length of piping (kg)
φ6,4	0,019
φ9,5	0,049
φ12,7	0,096
φ15,9	0,153

ADDITIONAL REFRIGERANT CHARGE AMOUNT
(ACCORDING TO CONNECTED INDOOR UNIT CAPACITY)

Connected indoor unit capacity (× 1000W)	Additional refrigerant R32 charge per 1000W capacity (kg)
A	0,0238

OUTDOOR UNITS

SDV6 SMALL INDIVIDUAL SIDE DISCHARGE R410A

MODEL			SDV6-E80AS	SDV6-E100AS	SDV6-E120AS	SDV6-E140AS	SDV6-E160AS
Horse power (HP)		-	2,5	3,5	4,4	5	6
Power		phase / Hz / V	1 ~ / 50 / 220-240	1 ~ / 50 / 220-240	1 ~ / 50 / 220-240	1 ~ / 50 / 220-240	1 ~ / 50 / 220-240
Cooling capacity		kW	7,2	9	12,3	14	15,5
Cooling input power		kW	2,21	2,9	3,97	5,19	5,96
EER		-	3,26	3,10	3,10	2,70	2,60
SEER			5,40	5,40	7,20	7,00	6,80
$\eta_{s,c}$		%	-	-	285	277	269
Heating capacity		kW	7,2	9	12,3	14	15,5
Heating input power		kW	1,8	2,37	3	3,68	4,19
COP		-	4,00	3,80	4,10	3,80	3,70
SCOP			3,80	3,80	4,90	4,80	4,80
$\eta_{s,h}$			-	-	193	189	189
Combination of indoor units		-	50-160%*** of outdoor unit capacity				
Number of indoor units		-	5	6	8	10	11
Compressor		Type	DC inverter	DC inverter	DC inverter	DC inverter	DC inverter
		Qty	1	1	1	1	1
		Oil	RB75EA	RB75EA	RB75EA	RB75EA	RB75EA
Operating range-cooling		°C	-15-52	-15-52	-15-52	-15-52	-15-52
Operating range-heating		°C	-20-30	-20-30	-20-30	-20-30	-20-30
Sound pressure level		dB(A)	53	53	55	56	56
Sound power level		dB(A)	70	72	72	73	74
Airflow		m ³ /h	5200	5200	5000	5000	5000
Net weight		kg	80	80	94	94	94
Gross weight		kg	90	90	104	104	104
Net dimensions	w x h x d	mm	1073x864x523	1073x864x523	1073x864x523	1073x864x523	1073x864x523
Packing dimensions	w x h x d	mm	1120x980x560	1120x980x560	1120x980x560	1120x980x560	1120x980x560
Refrigerant		type	R410A	R410A	R410A	R410A	R410A
		kg	3,1	3,1	4,1	4,1	4,1
		t eq. CO ₂	6,47	6,47	8,56	8,56	8,56
Vertical pipe length *		m	30 / 20	30 / 20	50 / 40	50 / 40	50 / 40
Pipe length from 1. branch		m	30	30	40	40	40
Equivalent pipe length		m	60	60	120	120	120
Total pipe length		m	150	150	300	300	300
Pipe diameter - liquid side		mm	9,5	9,5	9,5	9,5	9,5
Pipe diameter - gas side		mm	15,9	15,9	15,9	15,9	15,9
ADDITIONAL TECHNICAL INFORMATION							
Screw holes distance of OD	w x d	mm	656x463	656x463	656x463	656x463	656x463
Communication cable		mm ²	3x0,75 shielded in case mixed IDU SDV5 and SDV6 or 2x0,75 in case only IDU SDV6 (more than 10pcs IDU SDV6 require reperature SDV6-RPT in case separate power supply of each IDU SDV6)				
Recommended power cable		mm ²	3x6,0	3x6,0	3x10,0	3x16,0	3x16,0
Recommended air switch		A	B25	B25	B32	B40	B40
EQUIPMENT							
Crancase heater			yes	yes	yes	yes	yes
Drain pipe connector			yes	yes	yes	yes	yes
Alarm signal			yes (dry-contact)	yes (dry-contact)	yes (dry-contact)	yes (dry-contact)	yes (dry-contact)
ON/OFF signal			yes (dry-contact)	yes (dry-contact)	yes (dry-contact)	yes (dry-contact)	yes (dry-contact)
Defrost signal			yes (dry-contact)	yes (dry-contact)	yes (dry-contact)	yes (dry-contact)	yes (dry-contact)
OPTIONAL ACCESSORIES							
Central controller with weekly timer			CCM-180A**				
Central controller with LAN access			CCM-270A**, SCC-61, SDV6-CLOUD				
BMS gateway			SDV5-MOD**, SDV5-BAC**, SDV6-MOD, SDV6-BAC				
Extension kit (2xXYE)			SDV5-EK**, SDV6-EK				

* Outdoor unit top max. / bottom max.

** Require to set on ODU protocol SDV5.

*** If there are non SDV6 series indoor units in system the total combination ratio must not exceed 130%.

The specification of products is subject to change based on further development of the units by the producer and can be changed without prior notice. Refer to rating label.

R410A (50% HFC-32, 50% HFC-125), GWP of refrigerant used: 2088.

Contains fluorinated greenhouse gases covered by the Kyoto Protocol.

Conditions under which has been performed measurements of technical parameters see last page.

Electrical connection scheme for power supply, communication and controller connection see page 42.

OUTDOOR UNITS

SDV6 SMALL INDIVIDUAL SIDE DISCHARGE R410A

MODEL			SDV6-E120AS-3	SDV6-E140AS-3	SDV6-E160AS-3		
Horse power (HP)		-	4,4	5	6		
Power		phase / Hz / V	3 ~ / 50 / 380-415	3 ~ / 50 / 380-415	3 ~ / 50 / 380-415		
Cooling capacity		kW	12,3	14	15,5		
Cooling input power		kW	3,97	5,19	5,96		
EER		-	3,10	2,70	2,60		
SEER			7,20	7,00	6,80		
$\eta_{s,c}$		%	285	277	269		
Heating capacity		kW	12,3	14	15,5		
Heating input power		kW	3	3,68	4,19		
COP		-	4,10	3,80	3,70		
SCOP			4,90	4,80	4,80		
$\eta_{s,h}$			193	189	189		
Combination of indoor units		-	50-160%*** of outdoor unit capacity				
Number of indoor units		-	8	10	11		
Compressor		Type	DC inverter	DC inverter	DC inverter		
		Qty	1	1	1		
		Oil	RB75EA	RB75EA	RB75EA		
Operating range-cooling		°C	-15-52	-15-52	-15-52		
Operating range-heating		°C	-20-30	-20-30	-20-30		
Sound pressure level		dB(A)	55	56	56		
Sound power level		dB(A)	72	73	74		
Airflow		m ³ /h	5000	5000	5000		
Net weight		kg	109	109	109		
Gross weight		kg	119	119	119		
Net dimensions	w x h x d	mm	1073x864x523	1073x864x523	1073x864x523		
Packing dimensions	w x h x d	mm	1120x980x560	1120x980x560	1120x980x560		
Refrigerant		type	R410A	R410A	R410A		
		kg	4,1	4,1	4,1		
		t eq. CO ₂	8,56	8,56	8,56		
Vertical pipe length *		m	50 / 40	50 / 40	50 / 40		
Pipe length from 1. branch		m	40	40	40		
Equivalent pipe length		m	120	120	120		
Total pipe length		m	300	300	300		
Pipe diameter - liquid side		mm	9,5	9,5	9,5		
Pipe diameter - gas side		mm	15,9	15,9	15,9		
ADDITIONAL TECHNICAL INFORMATION							
Screw holes distance of OD	w x d	mm	656x463	656x463	656x463		
Communication cable		mm ²	3x0,75 shielded in case mixed IDU SDV5 and SDV6 or 2x0,75 in case only IDU SDV6 (more than 10pcs IDU SDV6 require repeater SDV6-RPT in case separate power supply of each IDU SDV6)				
Recommended power cable		mm ²	5x4,0	5x4,0	5x4,0		
Recommended air switch		A	B20	B20	B20		
EQUIPMENT							
Crancase heater			yes	yes	yes		
Drain pipe connector			yes	yes	yes		
Alarm signal			yes (dry-contact)	yes (dry-contact)	yes (dry-contact)		
ON/OFF signal			yes (dry-contact)	yes (dry-contact)	yes (dry-contact)		
Defrost signal			yes (dry-contact)	yes (dry-contact)	yes (dry-contact)		
OPTIONAL ACCESSORIES							
Central controller with weekly timer			CCM-180A**				
Central controller with LAN access			CCM-270A**, SCC-61, SDV6-CLOUD				
BMS gateway			SDV5-MOD**, SDV5-BAC**, SDV6-MOD, SDV6-BAC				
Extension kit (2xXYE)			SDV5-EK**, SDV6-EK				

* Outdoor unit top max. / bottom max.

** Require to set on ODU protocol SDV5.

*** If there are non SDV6 series indoor units in system the total combination ratio must not exceed 130%.

The specification of products is subject to change based on further development of the units by the producer and can be changed without prior notice. Refer to rating label.

R410A (50% HFC-32, 50% HFC-125), GWP of refrigerant used: 2088.

Contains fluorinated greenhouse gases covered by the Kyoto Protocol.

Conditions under which has been performed measurements of technical parameters see last page.

Electrical connection scheme for power supply, communication and controller connection see page 42.

APPEARANCE AND DIMENSIONS OF OUTDOOR UNIT

SDV6 SMALL INDIVIDUAL SIDE DISCHARGE R410A

SDV6-E80-160AS/AS-3

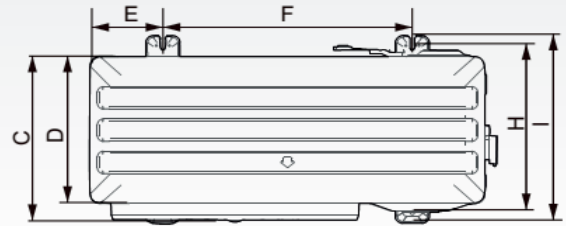
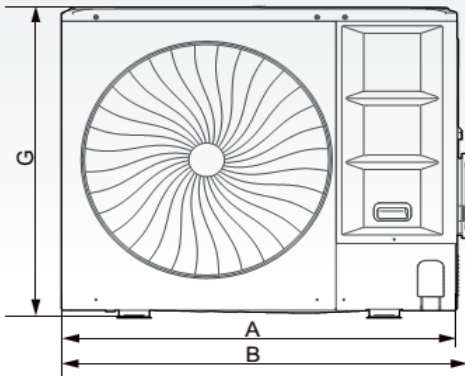

Model	SDV6-E80-160AS/AS-3
A (mm)	1038
B (mm)	1073
C (mm)	454
D (mm)	409
E (mm)	191
F (mm)	656
G (mm)	864
H (mm)	463
I (mm)	523

ALLOWED LENGTH AND DROP HEIGHT OF CONNECTION (See installation manual)

Additional refrigerant:

Calculate the added refrigerant according to the diameter and the length of the liquid side pipe of the outdoor unit/indoor unit connection.

When the outdoor unit connects 1 meter.

ADDITIONAL REFRIGERANT

Liquid side piping (mm)	Additional ref. charge R410A per meter of equivalent length of piping (kg)
φ6,4	0,022
φ9,5	0,057
φ12,7	0,11
φ15,9	0,17

OUTDOOR UNITS

SDV5 INDIVIDUAL SIDE DISCHARGE

MODEL			SDV5-200EAS	SDV5-224EAS	SDV5-260EAS	SDV5-280EAS	SDV5-335EAS
Horse power (HP)		-	7	8	9	10	12
Power		phase / Hz / V	3 ~ / 50 / 380-415	3 ~ / 50 / 380-415	3 ~ / 50 / 380-415	3 ~ / 50 / 380-415	3 ~ / 50 / 380-415
Cooling capacity		kW	20	22,4	26	28	33,5
Cooling input power		kW	5,28	6,77	10,04	12,02	15,30
EER		-	3,79	3,31	2,59	2,33	2,19
Heating capacity		kW	20	22,4	26	28	33,5
Heating input power		kW	4,43	5,42	6,86	7,55	10,15
COP		-	4,51	4,13	3,79	3,71	3,30
Combination of indoor units		-	50-130% of outdoor unit capacity				
Number of indoor units		-	11	13	15	16	20
Compressor		Type	DC inverter	DC inverter	DC inverter	DC inverter	DC inverter
		Qty	1	1	1	1	1
		Oil	RB74AF	RB74AF	RB74AF	RB74AF	FV50S
Operating range-cooling		°C	-5~48	-5~48	-5~48	-5~48	-5~48
Operating range-heating		°C	-20~24	-20~24	-20~24	-20~24	-20~24
Sound pressure level		dB(A)	58	58	58	60	61
Sound power level		dB(A)	78	78	78	78	81
Airflow		m³/h	9000	9000	10000	11000	11300
Net weight		kg	143	143	144	144	157
Gross weight		kg	159	159	160	160	173
Net dimensions	w x h x d	mm	1120x1558x528	1120x1558x528	1120x1558x528	1120x1558x528	1120x1558x528
Packing dimensions	w x h x d	mm	1270x1720x565	1270x1720x565	1270x1720x565	1270x1720x565	1270x1720x565
Refrigerant		type	R410A	R410A	R410A	R410A	R410A
		kg	6,5	6,5	6,5	6,5	8,0
		t eq. CO ₂	13,6	13,6	13,6	13,6	16,7
Vertical pipe length *		m	50 / 40				
Pipe length from 1. branch		m	40	40	40	40	40
Equivalent pipe length		m	110	110	110	110	110
Total pipe length		m	150	150	150	150	150
Pipe diameter - liquid side		mm	12,7	9,5	9,5	9,5	12,7
Pipe diameter - gas side		mm	19,1	19,1	22,2	22,2	25,4
ADDITIONAL TECHNICAL INFORMATION							
Screw holes distance of OD	w x d	mm	(668+206)x494	(668+206)x494	(668+206)x494	(668+206)x494	(668+206)x494
Communication cable		mm²	3x0,75 shielded	3x0,75 shielded	3x0,75 shielded	3x0,75 shielded	3x0,75 shielded
Recommended power cable		mm²	5x4,0	5x4,0	5x4,0	5x4,0	5x6,0
Recommended air switch		A	B25	B25	B25	B25	B32
EQUIPMENT							
Crancase heater			yes	yes	yes	yes	yes
Bottom plugs for OD			yes	yes	yes	yes	yes
Drain pipe connector			yes	yes	yes	yes	yes
STANDARD ACCESSORIES							
Gateway connection			yes	yes	yes	yes	yes
OPTIONAL ACCESSORIES							
Gateway connection			-	-	-	-	-
Wire controller			-	-	-	-	-
Central controller			CCM-180A, CCM-270A, SCM-30	CCM-180A, CCM-270A, SCM-30	CCM-180A, CCM-270A, SCM-30	CCM-180A, CCM-270A, SCM-30	CCM-180A, CCM-270A, SCM-30
Central controller with weekly timer			CCM-180A, CCM-270A	CCM-180A, CCM-270A	CCM-180A, CCM-270A	CCM-180A, CCM-270A	CCM-180A, CCM-270A
Central controller with LAN access			CCM15, CCM-270A	CCM15, CCM-270A	CCM15, CCM-270A	CCM15, CCM-270A	CCM15, CCM-270A
BMS gateway			GW-BAC, GW-LON, SDV5-MOD	GW-BAC, GW-LON, SDV5-MOD	GW-BAC, GW-LON, SDV5-MOD	GW-BAC, GW-LON, SDV5-MOD	GW-BAC, GW-LON, SDV5-MOD
Extension kit (2xXYE)			SDV5-EK	SDV5-EK	SDV5-EK	SDV5-EK	SDV5-EK

* Outdoor unit top max / bottom max.

The specification of products is subject to change based on further development of the units by the producer and can be changed without prior notice. Refer to rating label.

R410 (50% HFC-32, 50% HFC-125), GWP of refrigerant used: 2088.

Contains fluorinated greenhouse gases covered by the Kyoto Protocol.

Conditions under which has been performed measurements of technical parameters on last page.

APPEARANCE AND DIMENSIONS OF OUTDOOR UNIT

SDV5 INDIVIDUAL SIDE DISCHARGE

SDV5-200EAS/224EAS/260EAS/280EAS/335EAS

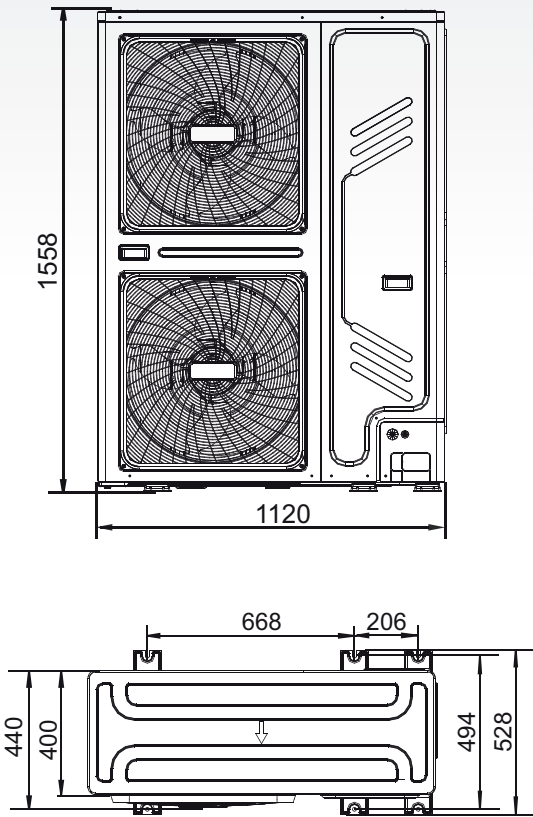

ALLOWED LENGTH AND DROP HEIGHT OF CONNECTION (See installation manual)

Additional refrigerant:

Calculate the added refrigerant according to the diameter and the length of the liquid side pipe of the outdoor unit/ indoor unit connection.

When the outdoor unit connects 1 meter.

Liquid side piping (mm)	Additional refrigerant charge per meter of equivalent length of piping (kg)
Φ6.4	0.022kg
Φ9.5	0.057kg
Φ12.7	0.110kg
Φ15.9	0.170kg
Φ19.1	0.260kg
Φ22.2	0.360kg
Φ25.4	0.520kg
Φ28.6	0.680kg

OUTDOOR UNITS

SDV6 INDIVIDUAL SIDE DISCHARGE

MODEL			SDV6-E400ASI	SDV6-E450ASI	SDV6-E500ASI	SDV6-E560ASI	SDV6-E615ASI
Horse power (HP)		-	14	16	18	20	22
Power		phase / Hz / V	3 ~ / 50 / 380-415	3 ~ / 50 / 380-415	3 ~ / 50 / 380-415	3 ~ / 50 / 380-415	3 ~ / 50 / 380-415
Cooling capacity		kW	40	45	50	56	61,5
Cooling input power		kW	15,7	16	19,5	22,9	30,8
EER		-	2,55	2,81	2,56	2,45	2,00
Heating capacity		kW	40	45	50	56	61,5
Heating input power		kW	11,7	12,2	13,7	15,5	18,8
COP		-	3,42	3,69	3,65	3,61	3,27
SEER		-	6,23	6,15	6,08	5,95	5,80
η_s, c		%	263,0	267,8	255,8	249,0	243,0
SCOP		-	4,00	4,10	4,15	4,07	4,00
η_s, h		%	163,0	166,2	163,8	159,8	157,0
Combination of indoor units		-	50-130% of outdoor unit capacity				
Number of indoor units		-	22	26	29	33	36
Compressor		Type	DC inverter	DC inverter	DC inverter	DC inverter	DC inverter
		Qty	1	1	1	1	1
		Oil	FVC68D	FVC68D	FVC68D	FVC68D	FVC68D
Operating range-cooling		°C	-15~-55	-15~-55	-15~-55	-15~-55	-15~-55
Operating range-heating		°C	-30~-30	-30~-30	-30~-30	-30~-30	-30~-30
Sound pressure level		dB(A)	59	60	61	61	62
Sound power level		dB(A)	82	86	88	89	89
Airflow		m³/h	12500	18500	20000	18500	19000
Net weight		kg	187	214	214	234	234
Gross weight		kg	201	229	229	249	249
Net dimensions	w x h x d	mm	1130x1760x580	1250x1760x580	1250x1760x580	1250x1760x580	1250x1760x580
Packing dimensions	w x h x d	mm	1210x1916x597	1330x1916x597	1330x1916x597	1330x1916x597	1330x1916x597
Refrigerant		type	R410A	R410A	R410A	R410A	R410A
		kg	7,4	8,0	8,0	8,5	8,5
		t eq. CO ₂	3,54	3,83	3,83	4,07	4,07
Vertical pipe length *		m	50 / 40				
Pipe length from 1. branch		m	40	40	40	40	40
Total pipe length		m	560	560	560	560	560
Pipe diameter - liquid side		mm	12,7	15,9	15,9	15,9	15,9
Pipe diameter - gas side		mm	25,4	28,6	28,6	28,6	28,6
ADDITIONAL TECHNICAL INFORMATION							
Screw holes distance of OD	w x d	mm	(614+278)x534	(674+278)x534	(674+278)x534	(674+278)x534	(674+278)x534
Communication cable		mm²	3x0,75 shielded in case mixed IDU SDV5 and SDV6 or 2x0,75 in case only IDU SDV6 (more than 10pcs IDU SDV6 require repeater SDV6-RPT in case separate power supply of each IDU SDV6)				
Recommended power cable		mm²	5x6,0	5x6,0	5x6,0	5x10,0	5x10,0
Recommended air switch		A	B32	B40	B40	B50	B50
EQUIPMENT							
Crancase heater			yes	yes	yes	yes	yes
Alarm signal			yes (dry-contact)	yes (dry-contact)	yes (dry-contact)	yes (dry-contact)	yes (dry-contact)
ON/OFF signal			yes (dry-contact)	yes (dry-contact)	yes (dry-contact)	yes (dry-contact)	yes (dry-contact)
Defrost signal			yes (dry-contact)	yes (dry-contact)	yes (dry-contact)	yes (dry-contact)	yes (dry-contact)
OPTIONAL ACCESSORIES							
Central controller with weekly timer			CCM-180A**				
Central controller with LAN access			CCM-270A**, SCC-61, SDV6-CLOUD				
BMS gateway			SDV5-MOD**, SDV5-BAC**, SDV6-MOD, SDV6-BAC				
Extension kit (2xXYE)			SDV5-EK**, SDV6-EK				

** Require to set on ODU protocol SDV5.

The specification of products is subject to change based on further development of the units by the producer and can be changed without prior notice. Refer to rating label.

R410 (50% HFC-32, 50% HFC-125), GWP of refrigerant used: 2088.

Contains fluorinated greenhouse gases covered by the Kyoto Protocol.

Conditions under which has been performed measurements of technical parameters see last page.

Electrical connection scheme for power supply, communication and controller connection see page 42.

APPEARANCE AND DIMENSIONS OF OUTDOOR UNIT

SDV6 INDIVIDUAL SIDE DISCHARGE

SDV6-E400ASI

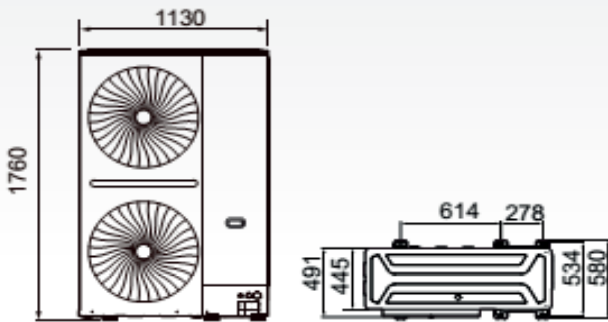

SDV6-E450/500/560/615ASI

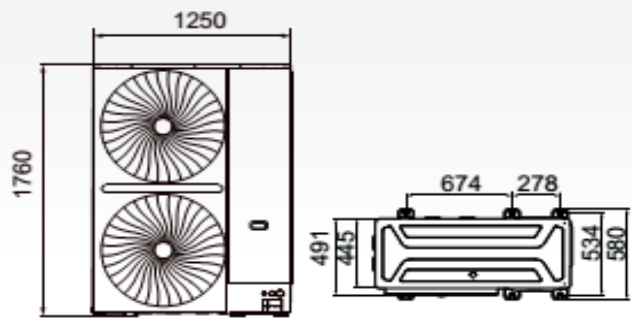

ALLOWED LENGTH AND DROP HEIGHT OF CONNECTION (See installation manual)

Additional refrigerant:

Calculate the added refrigerant according to the diameter and the length of the liquid side pipe of the outdoor unit/indoor unit connection.

When the outdoor unit connects 1 meter.

ADDITIONAL REFRIGERANT

Liquid side piping (mm)	Additional ref. charge R410A per meter of equivalent length of piping (kg)
Φ6,4	0,022
Φ9,5	0,057
Φ12,7	0,11
Φ15,9	0,17

OUTDOOR UNITS

SDV6 TOP AIR DISCHARGE INDIVIDUAL / SDV6 TOP AIR DISCHARGE MODULAR

MODEL			SDV6-E252ATI / SDV6-E252ATM	SDV6-E280ATI / SDV6-E280ATM	SDV6-E335ATI / SDV6-E335ATM	SDV6-E400ATI / SDV6-E400ATM	SDV6-E450ATI / SDV6-E450ATM
Horse power (HP)		-	8	10	12	14	16
Power		phase / Hz / V	3 ~ / 50 / 380-415	3 ~ / 50 / 380-415	3 ~ / 50 / 380-415	3 ~ / 50 / 380-415	3 ~ / 50 / 380-415
Cooling capacity		kW	25,2	28,0	33,5	40,0	45,0
Cooling input power		kW	8,4	9,9	13,5	17,0	22,0
EER		-	3,00	2,83	2,48	2,35	2,05
Heating capacity		kW	25,2	28,0	33,5	40,0	45,0
Heating input power		kW	6,6	7,5	10,8	11,6	14,0
COP		-	3,82	3,73	3,10	3,45	3,21
SEER		-	7,21	6,82	6,32	6,25	6,02
ηs, c		%	285,4	269,8	249,8	247,0	237,8
SCOP		-	4,1	4,1	4,1	4,1	4,0
ηs, h		%	160,2	159,8	160,6	161,8	157,8
Combination of indoor units		-	50-130% of outdoor unit capacity				
Number of indoor units		-	13	16	19	23	26
Compressor	Type		DC inverter EVI	DC inverter EVI	DC inverter EVI	DC inverter EVI	DC inverter EVI
	Qty		1	1	1	1	1
	Oil		FVC68D	FVC68D	FVC68D	FVC68D	FVC68D
Operating range-cooling		°C	-15-55	-15-55	-15-55	-15-55	-15-55
Operating range-heating		°C	-30-30	-30-30	-30-30	-30-30	-30-30
Sound pressure level		dB(A)	58	58	61	65	65
Sound power level		dB(A)	83	84	85	86	86
Airflow		m³/h	12600	12600	13500	15600	15600
Net weight		kg	195	195	195	215	215
Gross weight		kg	213	213	213	232	232
Net dimensions	w x h x d	mm	940x1760x825	940x1760x825	940x1760x825	940x1760x825	940x1760x825
Packing dimensions	w x h x d	mm	1005x1945x890	1005x1945x890	1005x1945x890	1005x1945x890	1005x1945x890
Refrigerant	type		R410A	R410A	R410A	R410A	R410A
	kg		7,0	7,0	7,0	8,4	8,4
	t eq. CO ₂		14,62	14,62	14,62	17,54	17,54
Vertical pipe length		m	110	110	110	110	110
Pipe length from 1. branch		m	40	40	40	40	40
Equivalent pipe length		m	260	260	260	260	260
Total pipe length		m	1100	1100	1100	1100	1100
Pipe diameter - liquid side		mm	12,7	12,7	12,7	15,9	15,9
Pipe diameter - gas side		mm	25,4	25,4	25,4	28,6	28,6
ADDITIONAL TECHNICAL INFORMATION							
Screw holes distance of OD	w x d	mm	705x710	705x710	705x710	705x710	705x710
Communication cable		mm ²	3x0,75 shielded in case mixed IDU SDV5 and SDV6 or 2x0,75 in case only IDU SDV6 (more than 10pcs IDU SDV6 require repeater SDV6-RPT in case separate power supply of each IDU SDV6)				
Recommended power cable		mm ²	5x4,0	5x4,0	5x6,0	5x6,0	5x6,0
Recommended air switch		A	B20	B25	B32	B32	B40
EQUIPMENT							
Cranecase heater			yes	yes	yes	yes	yes
Alarm signal			yes (dry-contact)	yes (dry-contact)	yes (dry-contact)	yes (dry-contact)	yes (dry-contact)
ON/OFF signal			yes (dry-contact)	yes (dry-contact)	yes (dry-contact)	yes (dry-contact)	yes (dry-contact)
Defrost signal			yes (dry-contact)	yes (dry-contact)	yes (dry-contact)	yes (dry-contact)	yes (dry-contact)
OPTIONAL ACCESSORIES							
Central controller with weekly timer			CCM-180A**				
Central controller with LAN access			CCM-270A**, SCC-61, SDV6-CLOUD				
BMS gateway			SDV5-MOD**, SDV5-BAC**, SDV6-MOD, SDV6-BAC				
Extension kit (2xXYE)			SDV5-EK**, SDV6-EK				

** Require to set on ODU protocol SDV5.

The specification of products is subject to change based on further development of the units by the producer and can be changed without prior notice. Refer to rating label.

R410 (50% HFC-32, 50% HFC-125), GWP of refrigerant used: 2088.

Contains fluorinated greenhouse gases covered by the Kyoto Protocol.

Conditions under which has been performed measurements of technical parameters see last page.

Electrical connection scheme for power supply, communication and controller connection see page 42.

APPEARANCE AND DIMENSIONS OF OUTDOOR UNIT

8/10/12/14/16HP

18/20/22/24HP

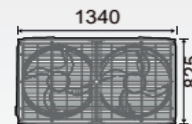
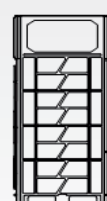
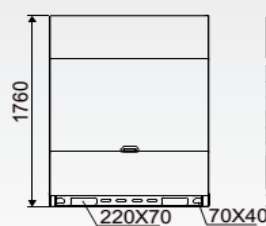
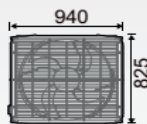
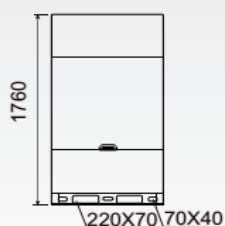

OUTDOOR UNITS

SDV6 TOP AIR DISCHARGE INDIVIDUAL / SDV6 TOP AIR DISCHARGE MODULAR

MODEL			SDV6-E500ATI / SDV6-E500ATM	SDV6-E560ATI / SDV6-E560ATM	SDV6-E615ATI / SDV6-E615ATM	SDV6-E670ATI / SDV6-E670ATM	SDV6-E730ATI / SDV6-E730ATM
Horse power (HP)		-	18	20	22	24	26
Power		phase / Hz / V	3 ~ / 50 / 380-415	3 ~ / 50 / 380-415	3 ~ / 50 / 380-415	3 ~ / 50 / 380-415	3 ~ / 50 / 380-415
Cooling capacity		kW	50,0	56,0	61,5	67,0	73,0
Cooling input power		kW	20,4	26,0	27,7	32,7	38,2
EER		-	2,45	2,15	2,22	2,05	1,91
Heating capacity		kW	50,0	56,0	61,5	67,0	73,0
Heating input power		kW	15,1	17,2	18,4	20,2	23,2
COP		-	3,31	3,26	3,34	3,32	3,15
SEER		-	6,11	6,00	5,93	5,98	5,68
ηs, c		%	241,4	237,0	234,2	236,2	224,2
SCOP		-	4,1	4,0	4,2	4,1	4,2
ηs, h		%	162,6	158,2	165,4	160,2	163,0
Combination of indoor units		-	50-130% of outdoor unit capacity				
Number of indoor units		-	29	33	36	39	43
Compressor	Type		DC inverter EVI	DC inverter EVI	DC inverter EVI	DC inverter EVI	DC inverter EVI
	Qty		2	2	2	2	2
	Oil		FVC68D	FVC68D	FVC68D	FVC68D	FVC68D
Operating range-cooling		°C	-15-55	-15-55	-15-55	-15-55	-15-55
Operating range-heating		°C	-30-30	-30-30	-30-30	-30-30	-30-30
Sound pressure level		dB(A)	65	66	66	67	68
Sound power level		dB(A)	88	89	89	92	93
Airflow		m³/h	22000	22000	21500	21500	29000
Net weight		kg	295	295	295	315	366
Gross weight		kg	315	315	315	335	396
Net dimensions	w x h x d	mm	1340x1760x825	1340x1760x825	1340x1760x825	1340x1760x825	1880x1760x825
Packing dimensions	w x h x d	mm	1405x1945x890	1405x1945x890	1405x1945x890	1405x1945x890	1945x1945x890
Refrigerant	type		R410A	R410A	R410A	R410A	R410A
	kg		9,3	9,3	9,3	11,96	11,96
	t eq. CO ₂		19,42	19,42	19,42	24,97	24,97
Vertical pipe length		m	110	110	110	110	110
Pipe length from 1. branch		m	40	40	40	40	40
Equivalent pipe length		m	260	260	260	260	260
Total pipe length		m	1100	1100	1100	1100	1100
Pipe diameter - liquid side		mm	15,9	15,9	15,9	15,9	22,2
Pipe diameter - gas side		mm	28,6	28,6	28,6	28,6	31,8
ADDITIONAL TECHNICAL INFORMATION							
Screw holes distance of OD	w x d	mm	1105x710	1105x710	1105x710	1105x710	1645x710
Communication cable		mm ²	3x0,75 shielded in case mixed IDU SDV5 and SDV6 or 2x0,75 in case only IDU SDV6 (more than 10pcs IDU SDV6 require repeater SDV6-RPT in case separate power supply of each IDU SDV6)				
Recommended power cable		mm ²	5x6,0	5x10,0	5x16,0	5x16,0	5x16,0
Recommended air switch		A	B40	B50	B50	B63	B63
EQUIPMENT							
Crancase heater							
Alarm signal			yes (dry-contact)	yes (dry-contact)	yes (dry-contact)	yes (dry-contact)	yes (dry-contact)
ON/OFF signal			yes (dry-contact)	yes (dry-contact)	yes (dry-contact)	yes (dry-contact)	yes (dry-contact)
Defrost signal			yes (dry-contact)	yes (dry-contact)	yes (dry-contact)	yes (dry-contact)	yes (dry-contact)
OPTIONAL ACCESSORIES							
Central controller with weekly timer			CCM-180A**				
Central controller with LAN access			CCM-270A**, SCC-61, SDV6-CLOUD				
BMS gateway			SDV5-MOD**, SDV5-BAC**, SDV6-MOD, SDV6-BAC				
Extension kit (2xXYE)			SDV5-EK**, SDV6-EK				

** Require to set on ODU protocol SDV5.

The specification of products is subject to change based on further development of the units by the producer and can be changed without prior notice. Refer to rating label.

R410 (50% HFC-32, 50% HFC-125), GWP of refrigerant used: 2088.

Contains fluorinated greenhouse gases covered by the Kyoto Protocol.

Conditions under which has been performed measurements of technical parameters see last page.

Electrical connection scheme for power supply, communication and controller connection see page 42.

APPEARANCE AND DIMENSIONS OF OUTDOOR UNIT

26/28/30/32HP



SDV6 TOP AIR DISCHARGE INDIVIDUAL / SDV6 TOP AIR DISCHARGE MODULAR

MODEL			SDV6-E785ATI / SDV6-E785ATM	SDV6-E850ATI / SDV6-E850ATM	SDV6-E900ATI / SDV6-E900ATM		
Horse power (HP)		-	28	30	32		
Power		phase / Hz / V	3 ~ / 50 / 380-415	3 ~ / 50 / 380-415	3 ~ / 50 / 380-415		
Cooling capacity		kW	78,5	85,0	90,0		
Cooling input power		kW	32,4	37,8	43,9		
EER		-	2,42	2,25	2,05		
Heating capacity		kW	78,5	85,0	90,0		
Heating input power		kW	24,5	27,3	29,9		
COP		-	3,20	3,11	3,01		
SEER		-	5,93	5,81	5,75		
ηs, c		%	234,2	229,4	227,0		
SCOP		-	4,1	4,0	4,0		
ηs, h		%	161,8	157,0	155,0		
Combination of indoor units		-	50-130% of outdoor unit capacity				
Number of indoor units		-	46	50	53		
Compressor		Type	DC inverter EVI	DC inverter EVI	DC inverter EVI		
		Qty	2	2	2		
		Oil	FVC68D	FVC68D	FVC68D		
Operating range-cooling		°C	-15-55	-15-55	-15-55		
Operating range-heating		°C	-30-30	-30-30	-30-30		
Sound pressure level		dB(A)	68	68	68		
Sound power level		dB(A)	93	93	93		
Airflow		m³/h	28000	28000	28000		
Net weight		kg	396	396	396		
Gross weight		kg	426	426	426		
Net dimensions	w x h x d	mm	1880x1760x825	1880x1760x825	1880x1760x825		
Packing dimensions	w x h x d	mm	1945x1945x890	1945x1945x890	1945x1945x890		
Refrigerant		type	R410A	R410A	R410A		
		kg	11,96	11,96	11,96		
		t eq. CO ₂	24,97	24,97	24,97		
Vertical pipe length		m	110	110	110		
Pipe length from 1. branch		m	40	40	40		
Equivalent pipe length		m	260	260	260		
Total pipe length		m	1100	1100	1100		
Pipe diameter - liquid side		mm	22,2	22,2	22,2		
Pipe diameter - gas side		mm	34,9	34,9	34,9		
ADDITIONAL TECHNICAL INFORMATION							
Screw holes distance of OD	w x d	mm	1645x710	1645x710	1645x710		
Communication cable		mm²	3x0,75 shielded in case mixed IDU SDV5 and SDV6 or 2x0,75 in case only IDU SDV6 (more than 10pcs IDU SDV6 require repeater SDV6-RPT in case separate power supply of each IDU SDV6)				
Recommended power cable		mm²	5x16,0	5x16,0	5x16,0		
Recommended air switch		A	B63	B80	B80		
EQUIPMENT							
Crancase heater			yes	yes	yes		
Alarm signal			yes (dry-contact)	yes (dry-contact)	yes (dry-contact)		
ON/OFF signal			yes (dry-contact)	yes (dry-contact)	yes (dry-contact)		
Defrost signal			yes (dry-contact)	yes (dry-contact)	yes (dry-contact)		
OPTIONAL ACCESSORIES							
Central controller with weekly timer			CCM-180A**				
Central controller with LAN access			CCM-270A**, SCC-61, SDV6-CLOUD				
BMS gateway			SDV5-MOD**, SDV5-BAC**, SDV6-MOD, SDV6-BAC				
Extension kit (2xXYE)			SDV5-EK**, SDV6-EK				

** Require to set on ODU protocol SDV5.

The specification of products is subject to change based on further development of the units by the producer and can be changed without prior notice. Refer to rating label.

R410 (50% HFC-32, 50% HFC-125), GWP of refrigerant used: 2088.

Contains fluorinated greenhouse gases covered by the Kyoto Protocol.

Conditions under which has been performed measurements of technical parameters see last page.

Electrical connection scheme for power supply, communication and controller connection see page 42.

CONNECTION PIPING DIMENSIONS

SDV6 TOP AIR DISCHARGE INDIVIDUAL / SDV6 TOP AIR DISCHARGE MODULAR

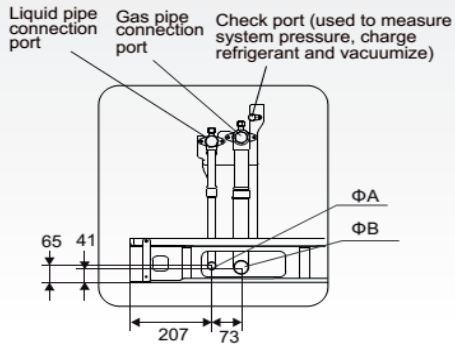

HP	8-12	14-16	18-24	26	28-32
SIZE					
ΦA(ID)	Φ12.7	Φ15.9	Φ19.1	Φ22.2	Φ22.2
ΦB(ID)	Φ25.4	Φ28.6	Φ31.8	Φ31.8	Φ38.1

EXPANSION BOLT POSITIONING

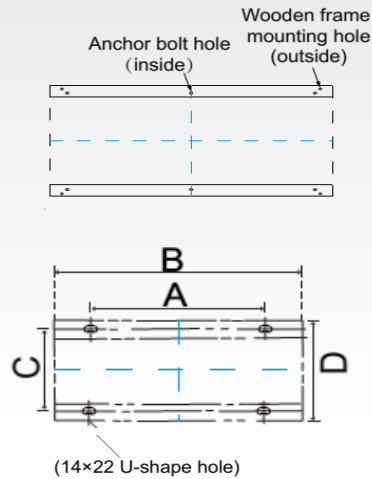

HP	Size	A	B	C	D	U-shaped hole
8-16HP		705	960	710	850	
18-24HP		1105	1360	710	850	Φ14*22
26-32HP		1645	1900	710	850	

ALLOWED LENGTH AND DROP HEIGHT OF CONNECTION

See installation manual

MODULAR OUTDOOR UNIT CONNECTION

ONLY SDV6-ExxxATM series

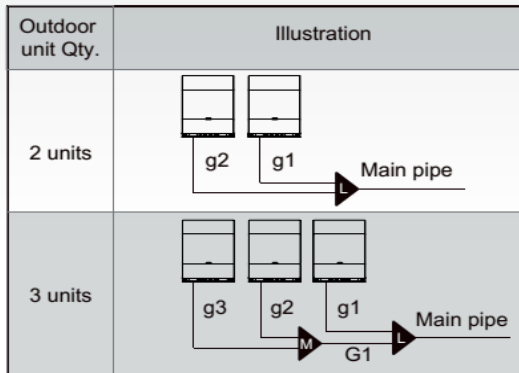

Outdoor unit Qty.	Total parallel capacity of outdoor units	Outdoor connection pipes diameter	Branch joint kit
2 units	< 56HP	g1、g2: 8~12HP: Φ25.4/Φ12.7; 14~24HP: Φ31.8/Φ15.9; 26~32HP: Φ38.1/Φ19.1;	L: SDV5- HW02N1M
	≥ 56HP	g1、g2: 20~24HP: Φ31.8/Φ15.9; 26~32HP: Φ38.1/Φ19.1;	L: SDV6- HW02N56M
3 units	≤ 96HP	g1、g2、g3: 8~12HP: Φ25.4/Φ12.7; 14~24HP: Φ31.8/Φ15.9; 26~32HP: Φ38.1/Φ19.1; G1: Φ41.3/Φ22.2	L+M: SDV5- HW03N1M

Additional refrigerant:

Calculate the added refrigerant according to the diameter and the length of the liquid side pipe of the outdoor unit/indoor unit connection.

When the outdoor unit connects 1 meter.

ADDITIONAL REFRIGERANT

Liquid side piping (mm)	Additional ref. charge R410A per meter of equivalent length of piping (kg)
Φ6,4	0,022
Φ9,5	0,057
Φ12,7	0,11
Φ15,9	0,17
Φ19,1	0,26
Φ22,2	0,36
Φ25,4	0,52
Φ28,4	0,68

HP	8-24	26	28-32
Additional ref. R410A charge (kg)	0	7	9

OUTDOOR UNITS

SDV5-3P HEAT RECOVERY MODULAR

MODEL			SDV5-252EA3P	SDV5-280EA3P	SDV5-335EA3P	SDV5-400EA3P	SDV5-450EA3P
Horse power (HP)		-	8	10	12	14	16
Power		phase / Hz / V	3 ~ / 50 / 380-415	3 ~ / 50 / 380-415	3 ~ / 50 / 380-415	3 ~ / 50 / 380-415	3 ~ / 50 / 380-415
Cooling capacity		kW	22,4	28,0	33,5	40,0	45,0
Cooling input power		kW	6,55	9,79	11,88	13,2	17,44
EER		-	3,42	2,86	2,82	3,03	2,58
Heating capacity		kW	22,4	28,0	33,5	40,0	45,0
Heating input power		kW	5,01	6,91	9,03	10,05	12,2
COP		-	4,47	4,05	3,71	3,98	3,69
Combination of indoor units		-	50-200% of outdoor unit capacity				
Number of indoor units		-	64	64	64	64	64
Compressor		Type	DC inverter	DC inverter	DC inverter	DC inverter	DC inverter
		Qty	1	1	1	2	2
		Oil	FV68H	FV68H	FV68H	FV68H	FV68H
Operating range-cooling		°C	-15-52	-15-52	-15-52	-15-52	-15-52
Operating range-heating		°C	-25-19	-25-19	-25-19	-25-19	-25-19
Operating range for hydrobox		°C	-20-43	-20-43	-20-43	-20-43	-20-43
Sound pressure level		dB(A)	58	58	60	61	64
Sound power level		dB(A)	78	78	81	81	88
Airflow		m³/h	9000	9500	10000	14000	14900
Net weight		kg	232	232	232	300	300
Gross weight		kg	248	248	248	325	325
Net dimensions	w x h x d	mm	990x1635x790	990x1635x790	990x1635x790	1340x1635x825	1340x1635x825
Packing dimensions	w x h x d	mm	1090x1805x860	1090x1805x860	1090x1805x860	1405x1805x910	1405x1805x910
Refrigerant		type	R410A	R410A	R410A	R410A	R410A
		kg	8	8	8	10,0	10,0
		t eq. CO ₂	16,7	16,7	16,7	20,9	20,9
Vertical pipe length *		m	110 / 110				
Pipe length from 1. branch		m	40	40	40	40	40
Equivalent pipe length		m	200	200	200	200	200
Total pipe length		m	1000	1000	1000	1000	1000
Pipe diameter - liquid side		mm	12,7	12,7	12,7	15,9	15,9
Pipe diameter - low pressure gas side		mm	25,4	25,4	25,4	28,6	28,6
Pipe diameter - high pressure gas side		mm	19,1	19,1	19,1	22,2	22,2
ADDITIONAL TECHNICAL INFORMATION							
Screw holes distance of OD	w x d	mm	740x723	740x723	740x723	1090x723	1090x723
Communication cable		mm²	3x0,75 shielded	3x0,75 shielded	3x0,75 shielded	3x0,75 shielded	3x0,75 shielded
Recommended power cable		mm²	5x4,0	5x4,0	5x4,0	5x6,0	5x6,0
Recommended air switch		A	B20	B25	B25	B30	B35
EQUIPMENT							
Crancase heater			yes	yes	yes	yes	yes
Bottom plugs for OD			-	-	-	-	-
Drain pipe connector			-	-	-	-	-
STANDARD ACCESSORIES							
Gateway connection			yes	yes	yes	yes	yes
OPTIONAL ACCESSORIES							
Central controller			CCM-180A, CCM-270A, SCM-30	CCM-180A, CCM-270A, SCM-30	CCM-180A, CCM-270A, SCM-30	CCM-180A, CCM-270A, SCM-30	CCM-180A, CCM-270A, SCM-30
Central controller with weekly timer			CCM-180A, CCM-270A	CCM-180A, CCM-270A	CCM-180A, CCM-270A	CCM-180A, CCM-270A	CCM-180A, CCM-270A
Central controller with LAN access			CCM15, CCM-270A	CCM15, CCM-270A	CCM15, CCM-270A	CCM15, CCM-270A	CCM15, CCM-270A
Central controller with software IMMPRO			CCM-270A	CCM-270A	CCM-270A	CCM-270A	CCM-270A
BMS gateway			GW-BAC, GW-LON, SDV5-MOD	GW-BAC, GW-LON, SDV5-MOD	GW-BAC, GW-LON, SDV5-MOD	GW-BAC, GW-LON, SDV5-MOD	GW-BAC, GW-LON, SDV5-MOD
Extension kit (2xXYE)			SDV5-EK	SDV5-EK	SDV5-EK	SDV5-EK	SDV5-EK

* Outdoor unit top max / bottom max. The specification of products is subject to change based on further development of the units by the producer and can be changed without prior notice. Refer to rating label. R410 (50% HFC-32, 50% HFC-125), GWP of refrigerant used: 2088. Contains fluorinated greenhouse gases covered by the Kyoto Protocol. Conditions under which has been performed measurements of technical parameters see last page. Modular units could be combined to one refrigerant circuit up to 3 pcs max. 150 kW.

APPEARANCE AND DIMENSIONS OF OUTDOOR UNIT

8, 10, 12 HP

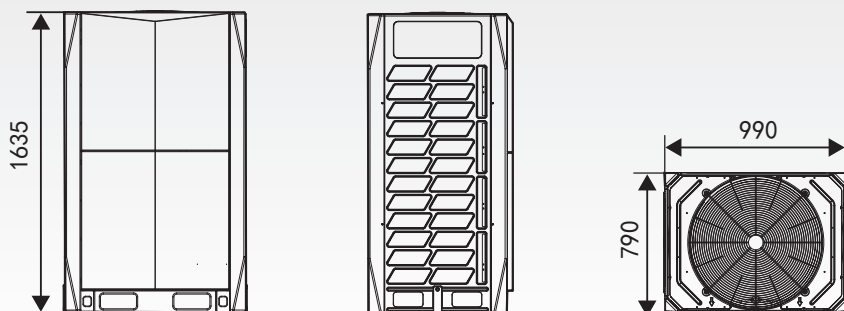

OUTDOOR UNITS

SDV5-3P HEAT RECOVERY MODULAR

MODEL			SDV5-500EA3P
Horse power (HP)		-	18
Power		phase / Hz / V	3 ~ / 50 / 380-415
Cooling capacity		kW	50,0
Cooling input power		kW	22,03
EER		-	2,27
Heating capacity		kW	50,0
Heating input power		kW	13,48
COP		-	3,71
Combination of indoor units		-	50-200% of OD unit capacity
Number of indoor units		-	64
Compressor		Type	DC inverter
		Qty	2
		Oil	FV68H
Operating range-cooling		°C	-15-52
Operating range-heating		°C	-25-19
Operating range for hydrobox		°C	-20-43
Sound pressure level		dB(A)	65
Sound power level		dB(A)	88
Airflow		m³/h	15800
Net weight		kg	300
Gross weight		kg	325
Net dimensions	w x h x d	mm	1340x1635x825
Packing dimensions	w x h x d	mm	1405x1805x910
Refrigerant		type	R410A
		kg	10,0
		t eq. CO ₂	20,9
Vertical pipe length *		m	110 / 110
Pipe length from 1. branch		m	40
Equivalent pipe length		m	200
Total pipe length		m	1000
Pipe diameter - liquid side		mm	15,9
Pipe diameter - low pressure gas side		mm	28,6
Pipe diameter - high pressure gas side		mm	22,2
ADDITIONAL TECHNICAL INFORMATION			
Screw holes distance of OD	w x d	mm	1090x723
Communication cable		mm²	3x0,75 shielded
Recommended power cable		mm²	5x6,0
Recommended air switch		A	B40
EQUIPMENT			
Crancase heater			yes
Bottom plugs for OD			-
Drain pipe connector			-
STANDARD ACCESSORIES			
Gateway connection			yes
OPTIONAL ACCESSORIES			
Central controller			CCM-180A, CCM-270A, SCM-30
Central controller with weekly timer			CCM-180A, CCM-270A
Central controller with LAN access			CCM15, CCM-270A
Central controller with software IMMPRO			CCM-270A
BMS gateway			GW-BAC, GW-LON, SDV5-MOD
Extension kit (2xXYE)			SDV5-EK

APPEARANCE AND DIMENSIONS OF OUTDOOR UNIT

8, 10, 12 HP

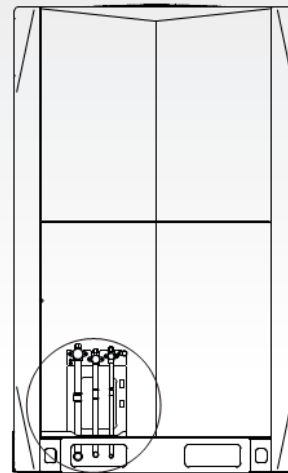

14, 16, 18 HP

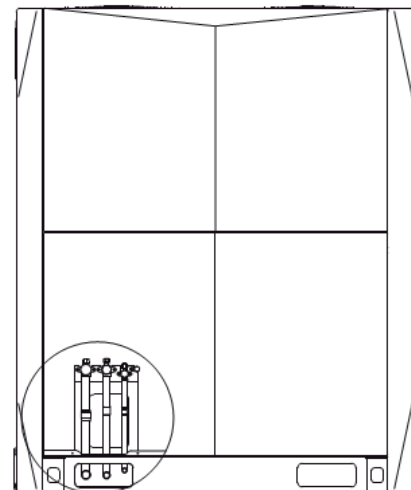

* Outdoor unit top max / bottom max. The specification of products is subject to change based on further development of the units by the producer and can be changed without prior notice. Refer to rating label. R410 (50% HFC-32, 50% HFC-125), GWP of refrigerant used: 2088. Contains fluorinated greenhouse gases covered by the Kyoto Protocol. Conditions under which has been performed measurements of technical parameters see last page. Modular units could be combined to one refrigerant circuit up to 3 pcs max. 150 kW.

APPEARANCE AND DIMENSIONS OF OUTDOOR UNIT

14, 16, 18 HP

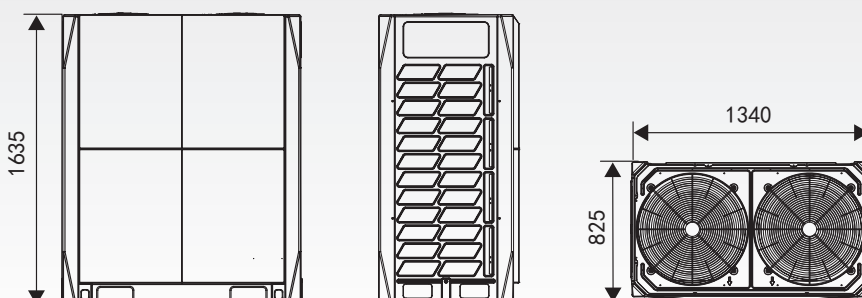

APPEARANCE AND DIMENSIONS OF OUTDOOR UNIT

SDV5-3P HEAT RECOVERY MODULAR

8-12 HP

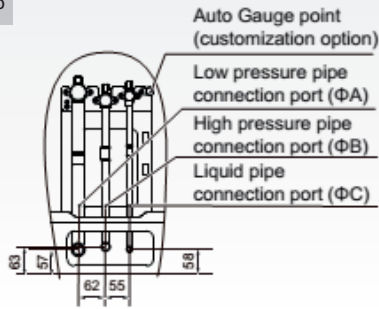

14-18 HP

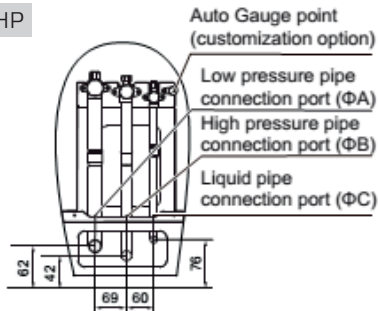

POSITION ILLUSTRATION OF SCREW BOLT

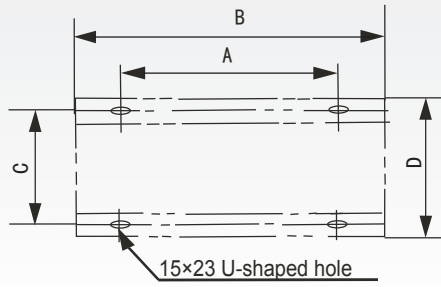

HP SIZE	8, 10, 12	14, 16, 18
A	740	1090
B	990	1340
C	723	723
D	790	790

HP SIZE	8	10	12	14	16	18
ΦA	19.1	22.2	28.6	28.6	28.6	28.6
ΦB	15.9	19.1	19.1	22.2	22.2	22.2
ΦC	9.52	9.52	12.7	12.7	12.7	15.9

ALLOWED LENGTH AND DROP HEIGHT OF CONNECTION
(See installation manual)

Liquid piping Diameter (mm OD)	Additional refrigerant charge per meter of equivalent length of liquid piping (kg)
Φ6.35	0.022
Φ9.53	0.057
Φ12.7	0.110
Φ15.9	0.170
Φ19.1	0.260
Φ22.2	0.360
Φ25.4	0.520
Φ28.6	0.680

Outdoor unit model	Additional refrigerant charge per model (kg)
8HP	2
10HP	2
12HP	2.6
14HP	4.9
16HP	5.5
18HP	5.7

SDB box model	Additional refrigerant charge per model (kg)
SDB01	0.1
SDB04	0.5
SDB06	0.5
SDB08	1
SDB10	1
SDB12	1

SDV5-3P HEAT RECOVERY MODULAR

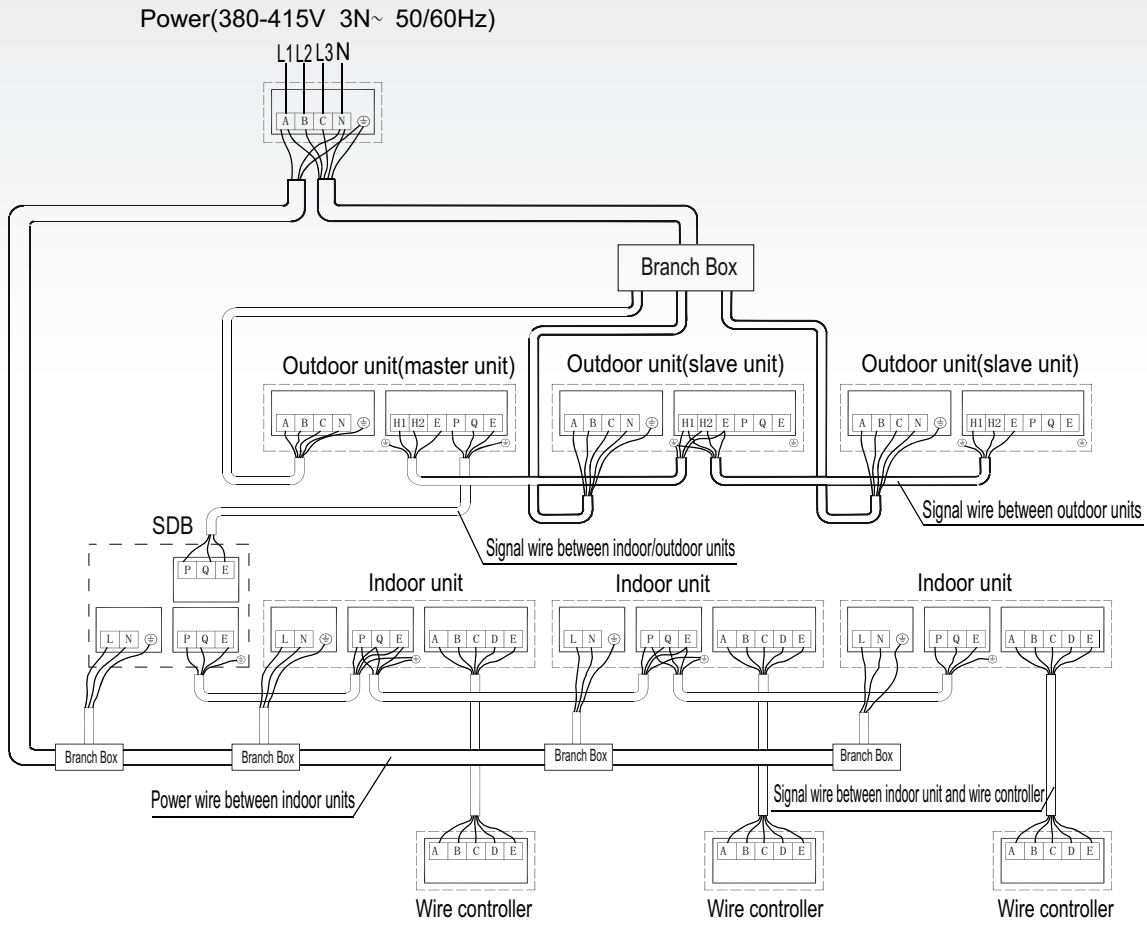

DISTRIBUTION BOXES

SDV5-3P HEAT RECOVERY MODULAR

MODEL				SDV5-01DB3P	SDV5-04DB3P	SDV5-06DB3P	SDV5-08DB3P	
Max. indoor unit groups			-	1	4	6	8	
Max. number of each group indoor units			-	8	5	5	5	
Max. number of all downstream indoor units			-	8	20	30	40	
Max. capacity of each group indoor units			kW	32	16	16	16	
Total capacity of all downstream indoor units			kW	≤32	≤49	≤63	≤85	
Piping connections	Connect to outdoor unit	Liquid pipe	mm	Φ9,53/12,7	Φ9,53/12,7/15,9/19,1	Φ9,53/12,7/15,9/19,1	Φ12,7/15,9/19,1/22,2	
		High pressure gas pipe	mm	Φ15,9/19,1/22,2	Φ19,1/22,2/28,6	Φ19,1/22,2/28,6	Φ22,2/28,6/34,9	
		Low pressure gas pipe	mm	Φ12,7/15,9/19,1	Φ15,9/19,1/22,2/28,6	Φ15,9/19,1/22,2/28,6	Φ19,1/22,2/28,6	
	Connect to indoor unit	Liquid pipe	mm	Φ6,4/9,5	Φ6,4/9,5	Φ6,4/9,5	Φ6,4/9,5	
	Gas pipe	mm	Φ12,7/15,9	Φ12,7/15,9	Φ12,7/15,9	Φ12,7/15,9		
Sound pressure level			dB(A)	40	44	45	47	
Net dimension			w x h x d	mm	440x195x296	668x250x574	668x250x574	974x250x574
Packing size			w x h x d	mm	740x275x405	1020x390x850	1020x390x850	1320x390x850
Net weight			kg	10,5	33	36	48	
Gross weight			kg	14	58	61	79	
MODEL				SDV5-10DB3P	SDV5-12DB3P			
Max. indoor unit groups			-	10	12			
Max. number of each group indoor units			-	5	5			
Max. number of all downstream indoor units			-	47	47			
Max. capacity of each group indoor units			kW	16	16			
Total capacity of all downstream indoor units			kW	≤85	≤85			
Piping connections	Connect to outdoor unit	Liquid pipe	mm	Φ12,7/15,9/19,1/22,2	Φ12,7/15,9/19,1/22,2			
		High pressure gas pipe	mm	Φ22,2/28,6/34,9	Φ22,2/28,6/34,9			
		Low pressure gas pipe	mm	Φ19,1/22,2/28,6	Φ19,1/22,2/28,6			
	Connect to indoor unit	Liquid pipe	mm	Φ6,4/9,5	Φ6,4/9,5			
	Gas pipe	mm	Φ12,7/15,9	Φ12,7/15,9				
Sound pressure level			dB(A)	47	47			
Net dimension			w x h x d	mm	974x250x574	974x250x574		
Packing size			w x h x d	mm	1320x390x850	1320x390x850		
Net weight			kg	51	54			
Gross weight			kg	82	85			

The specification of products is subject to change based on further development of the units by the producer and can be changed without prior notice. Refer to rating label. R410 (50% HFC-32, 50% HFC-125), GWP of refrigerant used: 2088. Contains fluorinated greenhouse gases covered by the Kyoto Protocol. Conditions under which has been performed measurements of technical parameters on last page.

APPEARANCE AND DIMENSIONS OF OUTDOOR UNIT

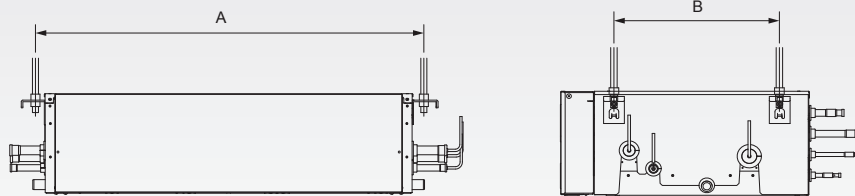

Mode selection box	A	B
SDV5-01	483	172
SDV5-04	702	383
SDV5-06		
SDV5-08	1008	
SDV5-10		
SDV5-12		

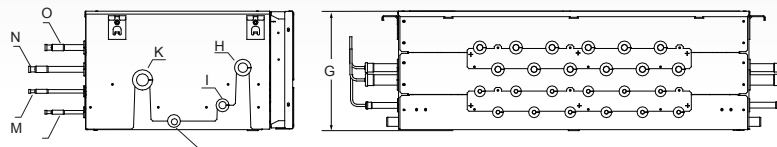

Model	A	B	C	D	E
04	889	702	668	700	574
06	889	702	668	700	574
08	1195	1008	974	700	574
10	1195	1008	974	700	574
12	1195	1008	974	700	574

Model	The multi SD boxF				
	G	H	I	J	
	383	250	Φ22.2	Φ15.9	Φ25

Model	The multi SD box				
	K	L	M	N	O
	Φ28.6	Φ9.52	Φ6.35	Φ12.7	Φ15.9

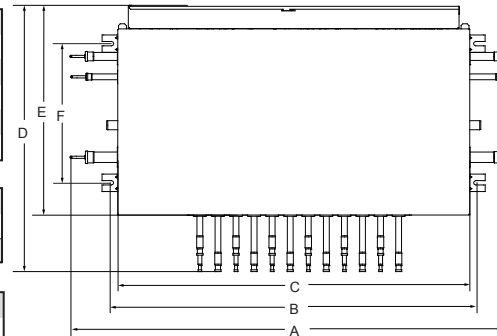
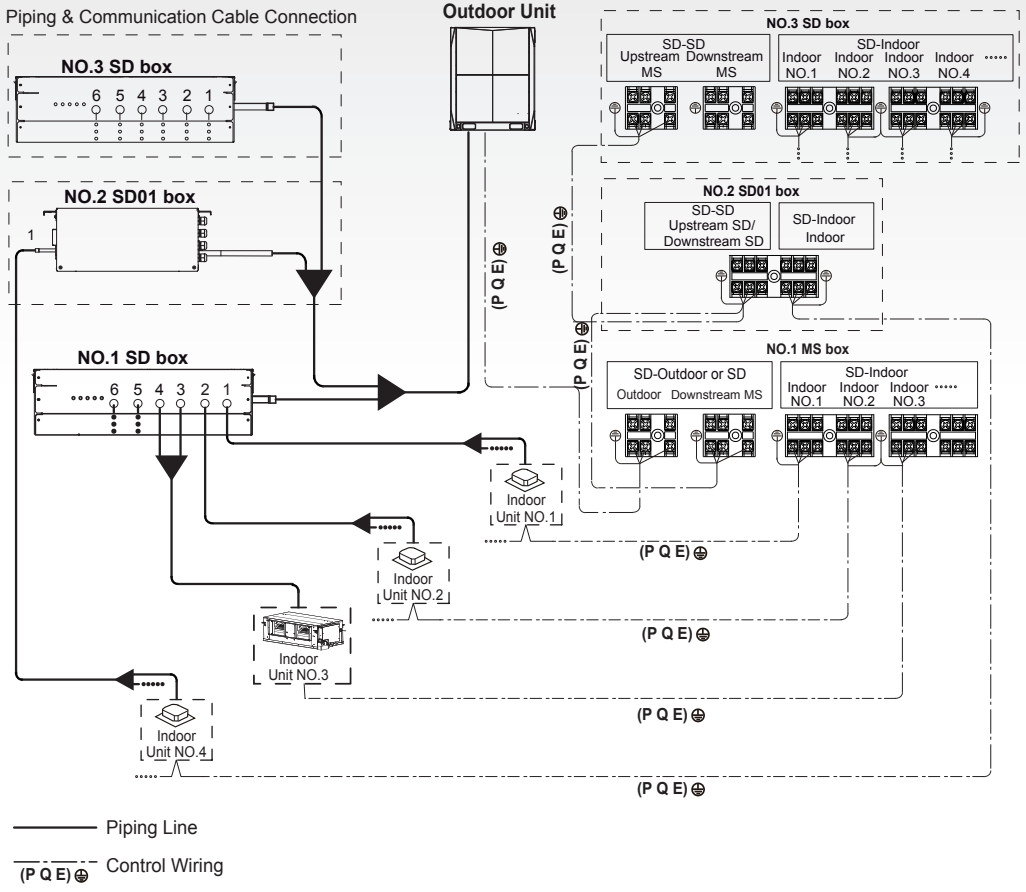

Fig.5-3

SDV5-3P HEAT RECOVERY MODULAR



SDV6 COMPACT FOUR WAY CASSETTE

MODEL			SDV6-CC15	SDV6-CC22	SDV6-CC28	SDV6-CC36	
Capacity cooling/heating		kW	1,5/1,8	2,2/2,4	2,8/3,2	3,6/4,0	
Power supply		phase / Hz / V	1 ~ / 50 / 220-240	1 ~ / 50 / 220-240	1 ~ / 50 / 220-240	1 ~ / 50 / 220-240	
Power input		W	14	14	16	18	
Air flow of ID	SH/MH/H/ML/ML/SL	m ³ /h	450/425/400/370/ 345/320/295	450/425/400/370/ 345/320/295	510/480/455/425/ 395/370/340	530/500/470/440/ 405/375/345	
Sound pressure level at 1,4m		dB(A)	29/28/27/27/26/26/25	29/28/27/27/26/26/25	30/29/28/27/26/26/25	31/30/29/28/27/26/26	
Sound power level		dB(A)	40/39/39/39/38/38/38	40/39/39/39/38/38/38	42/41/40/39/39/38/38	42/40/39/38/38/38/38	
Net dimensions of ID	w x h x d	mm	638x235x575	638x235x575	638x235x575	638x235x575	
Net dimensions of panel	w x h x d	mm	620x65x620	620x65x620	620x65x620	620x65x620	
Packing dimensions of ID	w x h x d	mm	690x285x690	690x285x690	690x285x690	690x285x690	
Packing dimensions of panel	w x h x d	mm	680x80x680	680x80x680	680x80x680	680x80x680	
Net weight of ID		kg	13	13	13	14	
Net weight of panel		kg	2,4	2,4	2,4	2,4	
Gross weight of ID		kg	15	15	15	16	
Gross weight of panel		kg	3,2	3,2	3,2	3,2	
Throttle		Type	Electromagnetic expansion valve				
Refrigerant		Type	R410A or R32				
Pipe diameter - liquid side		mm	6,4	6,4	6,4	6,4	
Pipe diameter - gas side		mm	12,7	12,7	12,7	12,7	
Pipe diameter - drainage		mm	25	25	25	25	
Set temperature range		°C	17-30	17-30	17-30	17-30	
ADDITIONAL TECHNICAL INFORMATION							
Communication cable		mm ²	3x0,75 shielded in case mixed IDU SDV5 and SDV6 or 2x0,75 in case only IDU SDV6 (more than 10pcs IDU SDV6 require reperature SDV6-RPT in case separate power supply of each IDU SDV6)				
Recommended power cable		mm ²	3x2,5	3x2,5	3x2,5	3x2,5	
Recommended air switch		A	B16	B16	B16	B16	
EQUIPMENT							
Drain pump			yes	yes	yes	yes	
Max. lift (from bottom of ID)		mm	1200	1200	1200	1200	
Alarm connector			yes (230V)	yes (230V)	yes (230V)	yes (230V)	
ON/OFF connector			yes (dry-contact)	yes (dry-contact)	yes (dry-contact)	yes (dry-contact)	
Fresh air inlet			yes (Φ100mm)	yes (Φ100mm)	yes (Φ100mm)	yes (Φ100mm)	
Separate louver control 1-4			yes**	yes**	yes**	yes**	
OPTIONAL ACCESSORIES							
Remote controller (IR)			SRC-61, RM05B***				
Wire controller			SWC-61, SWC-86ED***				
Group controller			SWC-61, SWC-62, SWC-63				
Wire controller - weekly timer, WiFi			SWC-62, SWC-63				
Central controller*			CCM-180A, CCM-270A, SCC-61, SDV6-CLOUD				
BMS gateway			SDV5-MOD*, SDV5-BAC*, SDV6-MOD*, SDV6-BAC*, KNX-03				

The specification of products is subject to change based on further development of the units by the producer and can be changed without prior notice. Refer to rating label.

Conditions under which has been performed measurements of technical parameters see last page.

* Connect to ODU SDV6 or ODU SDV5. SDV6-BAC and SDV6-MOD only support connection to ODU SDV6.

** This function support only SRC-61, SWC-62 or SWC-63.

*** Limited function.

Electrical connection scheme for power supply, communication and controller connection see page 42.

SDV6 COMPACT FOUR WAY CASSETTE

MODEL			SDV6-CC45	SDV6-CC56	SDV6-CC63
Capacity cooling/heating		kW	4,5/5,0	5,6/6,3	6,3/7,1
Power supply		phase / Hz / V	1 ~ / 50 / 220-240	1 ~ / 50 / 220-240	1 ~ / 50 / 220-240
Power input		W	25	35	50
Air flow of ID		m ³ /h	640/605/570/530/ 495/460/425	810/765/720/670/ 625/580/535	905/855/805/755/ 705/655/605
Sound pressure level at 1,4m	SH/MH/H/ML/ML/SL	dB(A)	37/35/33/31/29/28/27	39/38/37/36/35/34/32	43/42/40/38/36/35/34
Sound power level		dB(A)	44/44/43/42/41/41/41	48/46/45/43/42/42/41	51/50/48/46/45/44/42
Net dimensions of ID	w x h x d	mm	638x235x575	638x235x575	638x235x575
Net dimensions of panel	w x h x d	mm	620x65x620	620x65x620	620x65x620
Packing dimensions of ID	w x h x d	mm	690x285x690	690x285x690	690x285x690
Packing dimensions of panel	w x h x d	mm	680x80x680	680x80x680	680x80x680
Net weight of ID		kg	14	15	15
Net weight of panel		kg	2,4	2,4	2,4
Gross weight of ID		kg	16	17	17
Gross weight of panel		kg	3,2	3,2	3,2
Throttle		Type	Electromagnetic expansion valve		
Refrigerant		Type	R410A or R32		
Pipe diameter - liquid side		mm	6,4	6,4	9,5
Pipe diameter - gas side		mm	12,7	12,7	15,9
Pipe diameter - drainage		mm	25	25	25
Set temperature range		°C	17-30	17-30	17-30
ADDITIONAL TECHNICAL INFORMATION					
Communication cable		mm ²	3x0,75 shielded in case mixed IDU SDV5 and SDV6 or 2x0,75 in case only IDU SDV6 (more than 10pcs IDU SDV6 require reperature SDV6-RPT in case separate power supply of each IDU SDV6)		
Recommended power cable		mm ²	3x2,5	3x2,5	3x2,5
Recommended air switch		A	B16	B16	B16
EQUIPMENT					
Drain pump			yes	yes	yes
Max. lift (from bottom of ID)		mm	1200	1200	1200
Alarm connector			yes (230V)	yes (230V)	yes (230V)
ON/OFF connector			yes (dry-contact)	yes (dry-contact)	yes (dry-contact)
Fresh air inlet			yes (Φ100mm)	yes (Φ100mm)	yes (Φ100mm)
Separate louver control 1-4			yes**	yes**	yes**
OPTIONAL ACCESSORIES					
Remote controller (IR)			SRC-61, RM05B***		
Wire controller			SWC-61, SWC-86ED***		
Group controller			SWC-61, SWC-62, SWC-63		
Wire controller - weekly timer, WiFi			SWC-62, SWC-63		
Central controller*			CCM-180A, SCC-61		
BMS gateway			SDV5-MOD*, SDV5-BAC*, SDV6-MOD*, SDV6-BAC*, KNX-03		

The specification of products is subject to change based on further development of the units by the producer and can be changed without prior notice. Refer to rating label.

Conditions under which has been performed measurements of technical parameters see last page.

* Connect to ODU SDV6 or ODU SDV5. SDV6-BAC and SDV6-MOD only support connection to ODU SDV6.

** This function support only SRC-61, SWC-62 or SWC-63.

*** Limited function.

Electrical connection scheme for power supply, communication and controller connection see page 42.

APPEARANCE AND DIMENSIONS OF INDOOR UNIT

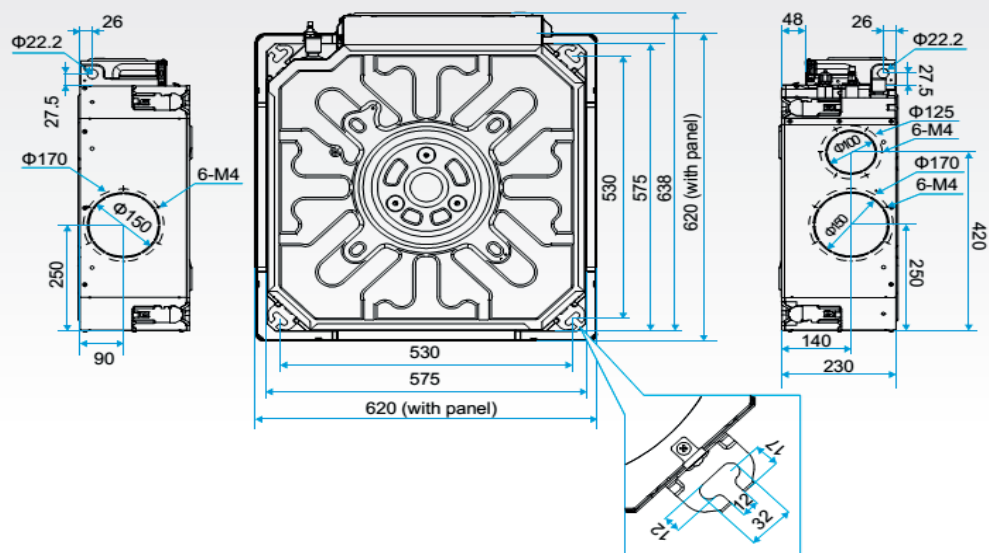

INDOOR UNITS

SDV6 FOUR WAY CASSETTE

MODEL			SDV6-C71	SDV6-C80	SDV6-C90	SDV6-C100	SDV6-C112
Capacity cooling/heating		kW	7,1/8,0	8,0/9,0	9,0/10,0	10,0/11,0	11,2/12,5
Power supply		phase / Hz / V	1 ~ / 50 / 220-240	1 ~ / 50 / 220-240	1 ~ / 50 / 220-240	1 ~ / 50 / 220-240	1 ~ / 50 / 220-240
Power input		W	31	41	43	54	61
Air flow of ID	SH/MH/H/M/L/ ML/SL	m³/h	1000/943/886/829/ 772/715/658	1330/1239/1148/1057/ 965/874/783	1330/1239/1148/1057/ 965/874/783	1445/1363/1282/1200/111 8/1037/955	1600/1497/1393/1290/118 6/1083/979
Sound pressure level at 1,4m		dB(A)	37/36/34/33/32/30/29	38/37/35/34/32/31/29	38/37/35/34/32/31/29	39/38/37/36/35/34/33	41/40/38/37/36/34/33
Sound power level		dB(A)	-	-	-	-	-
Net dimensions of ID	w x h x d	mm	840x204x840	840x204x840	840x246x840	840x288x840	840x288x840
Net dimensions of panel	w x h x d	mm	950x50x950	950x50x950	950x50x950	950x50x950	950x50x950
Packing dimensions of ID	w x h x d	mm	940x250x940	940x250x940	940x295x940	940x335x940	940x335x940
Packing dimensions of panel	w x h x d	mm	1020x90x1020	1020x90x1020	1020x90x1020	1020x90x1020	1020x90x1020
Net weight of ID		kg	22	22	22	24	24
Net weight of panel		kg	5,8	5,8	5,8	5,8	5,8
Gross weight of ID		kg	24,5	24,5	24,5	26,5	26,5
Gross weight of panel		kg	7,6	7,6	7,6	7,6	7,6
Throttle		Type	Electromagnetic expansion valve				
Refrigerant		Type	R410A or R32				
Pipe diameter - liquid side		mm	9,5	9,5	9,5	9,5	9,5
Pipe diameter - gas side		mm	15,9	15,9	15,9	15,9	15,9
Pipe diameter - drainage		mm	25	25	25	25	25
Set temperature range		°C	17-30	17-30	17-30	17-30	17-30
ADDITIONAL TECHNICAL INFORMATION							
Communication cable		mm²	3x0,75 shielded in case mixed IDU SDV5 and SDV6 or 2x0,75 in case only IDU SDV6 (more than 10pcs IDU SDV6 require repeater SDV6-RPT in case separate power supply of each IDU SDV6)				
Recommended power cable		mm²	3x2,5	3x2,5	3x2,5	3x2,5	3x2,5
Recommended air switch		A	B16	B16	B16	B16	B16
EQUIPMENT							
Drain pump			yes	yes	yes	yes	yes
Max. lift (from bottom of ID)		mm	1200	1200	1200	1200	1200
Alarm connector			yes (230V)	yes (230V)	yes (230V)	yes (230V)	yes (230V)
ON/OFF connector			yes (dry-contact)	yes (dry-contact)	yes (dry-contact)	yes (dry-contact)	yes (dry-contact)
Fresh air inlet			yes (Φ100mm)	yes (Φ100mm)	yes (Φ100mm)	yes (Φ100mm)	yes (Φ100mm)
Separate louver control 1-4			yes**	yes**	yes**	yes**	yes**
OPTIONAL ACCESSORIES							
Remote controller (IR)			SRC-61, RM05B***				
Wire controller			SWC-61, SWC-86ED***				
Group controller			SWC-61, SWC-62, SWC-63				
Wire controller - weekly timer, WiFi			SWC-62, SWC-63				
Central controller*			CCM-180A, CCM-270A, SCC-61, SDV6-CLOUD				
BMS gateway			SDV5-MOD*, SDV5-BAC*, SDV6-MOD*, SDV6-BAC*, KNX-03				

The specification of products is subject to change based on further development of the units by the producer and can be changed without prior notice. Refer to rating label.

Conditions under which has been performed measurements of technical parameters see last page.

* Connect to ODU SDV6 or ODU SDV5. SDV6-BAC and SDV6-MOD only support connection to ODU SDV6.

** This function support only SRC-61, SWC-62 or SWC-63.

*** Limited function.

Electrical connection scheme for power supply, communication and controller connection see page 42.

APPEARANCE AND DIMENSIONS OF INDOOR UNIT

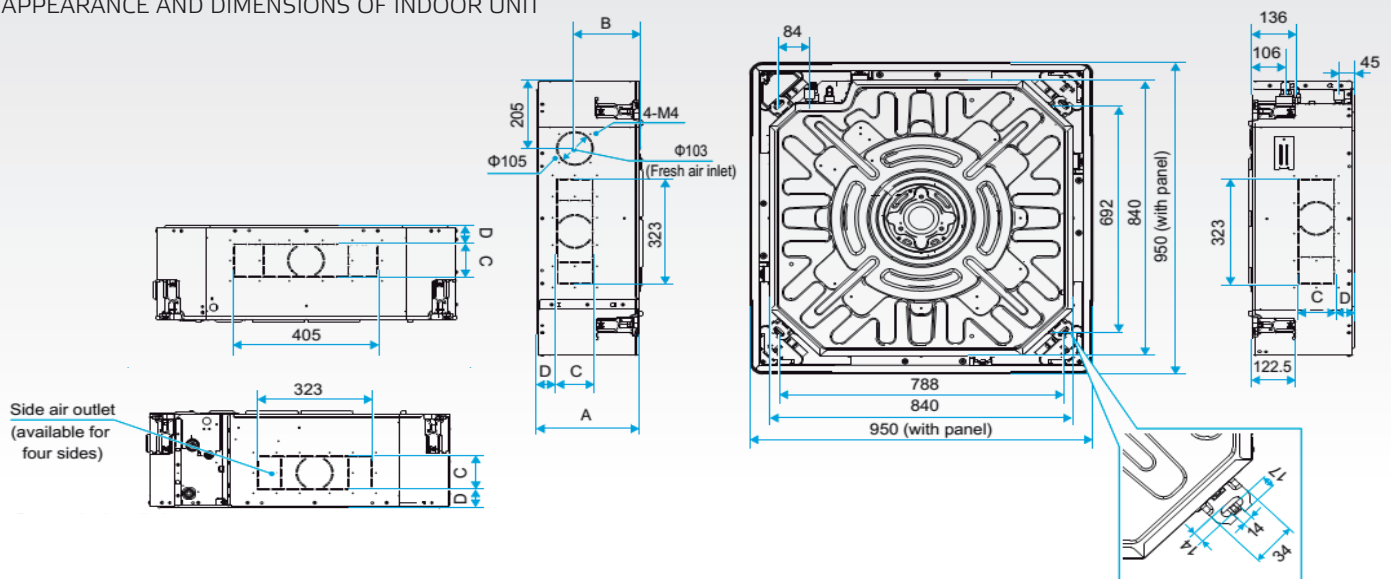

INDOOR UNITS

SDV6 FOUR WAY CASSETTE

MODEL			SDV6-C140
Capacity cooling/heating		kW	14,0/16,0
Power supply		phase / Hz / V	1 ~ / 50 / 220-240
Power input		W	89
Air flow of ID	SH/MH/H/ML/ ML/SL	m³/h	1600/1497/1393/1290/1186/1083/979
Sound pressure level at 1,4m		dB(A)	43/42/40/39/37/36/34
Sound power level		dB(A)	-
Net dimensions of ID	w x h x d	mm	840x288x840
Net dimensions of panel	w x h x d	mm	950x50x950
Packing dimensions of ID	w x h x d	mm	940x335x940
Packing dimensions of panel	w x h x d	mm	1020x90x1020
Net weight of ID		kg	26,5
Net weight of panel		kg	5,8
Gross weight of ID		kg	29
Gross weight of panel		kg	7,6
Throttle		Type	Electromagnetic expansion valve
Refrigerant		Type	R410A or R32
Pipe diameter - liquid side		mm	9,5
Pipe diameter - gas side		mm	15,9
Pipe diameter - drainage		mm	25
Set temperature range		°C	17-30
ADDITIONAL TECHNICAL INFORMATION			
Communication cable		mm²	3x0,75 shielded in case mixed IDU SDV5 and SDV6 or 2x0,75 in case only IDU SDV6 (more than 10pcs IDU SDV6 require repeater SDV6-RPT in case separate power supply of each IDU SDV6)
Recommended power cable		mm²	3x2,5
Recommended air switch		A	B16
EQUIPMENT			
Drain pump			yes
Max. lift (from bottom of ID)		mm	1200
Alarm connector			yes (230V)
ON/OFF connector			yes (dry-contact)
Fresh air inlet			yes (Φ100mm)
Separate louver control 1-4			yes**
OPTIONAL ACCESSORIES			
Remote controller (R)			SRC-61, RM05B***
Wire controller			SWC-61, SWC-86ED***
Group controller			SWC-61, SWC-62, SWC-63
Wire controller - weekly timer, WiFi			SWC-62, SWC-63
Central controller*			CCM-180A, CCM-270A, SCC-61, SDV6-CLOUD
BMS gateway			SDV5-MOD*, SDV5-BAC*, SDV6-MOD*, SDV6-BAC*, KNX-03

The specification of products is subject to change based on further development of the units by the producer and can be changed without prior notice. Refer to rating label.

Conditions under which has been performed measurements of technical parameters see last page.

* Connect to ODU SDV6 or ODU SDV5. SDV6-BAC and SDV6-MOD only support connection to ODU SDV6.

** This function support only SRC-61, SWC-62 or SWC-63.

*** Limited function.

Electrical connection scheme for power supply, communication and controller connection see page 42.

APPEARANCE AND DIMENSIONS OF INDOOR UNIT

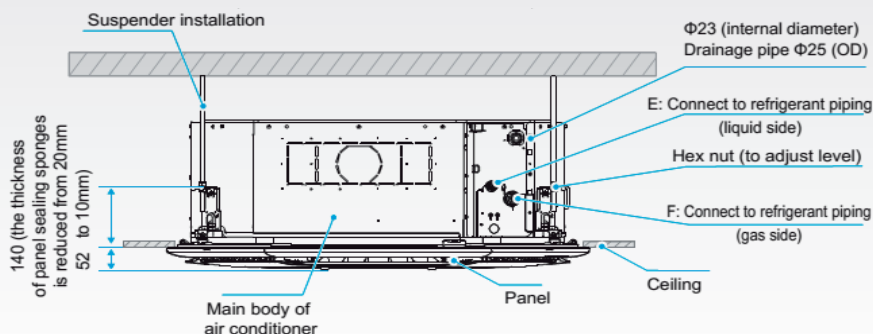

Model (kW)	7,1-9,0	9,0-14,0
A (mm)	246	288
B (mm)	163	190
C (mm)	103	103
D (mm)	41,5	56,5
E (mm)	Φ15,9	Φ15,9
F (mm)	Φ9,5	Φ9,5

SDV6 WALL-MOUNTED

MODEL			SDV6-H15(S)	SDV6-H22(S)	SDV6-H28(S)	SDV6-H36(S)	
Capacity cooling/heating		kW	1,5/1,8	2,2/2,4	2,8/3,2	3,6/4,0	
Power supply		phase / Hz / V	1 ~ / 50 / 220-240	1 ~ / 50 / 220-240	1 ~ / 50 / 220-240	1 ~ / 50 / 220-240	
Power input		W	18	21	24	27	
Air flow of ID	SH/MH/H/M/L/ ML/SL	m³/h	460/440/420/400/ 380/360/340	500/470/440/410/ 390/370/340	540/510/470/430/ 400/370/340	580/540/500/460/ 420/380/340	
Sound pressure level at 1m		dB(A)	32/31/30/30/29/28/27	33/32/31/30/29/28/27	35/34/33/32/31/30/28	37/36/34/33/31/30/28	
Sound power level		dB(A)	45/44/43/43/42/41/40	46/45/44/43/42/41/40	50/49/48/47/46/44/42	54/53/51/50/48/46/44	
Net dimensions	w x h x d	mm	750x295x265	750x295x265	750x295x265	750x295x265	
Packing dimensions	w x h x d	mm	875x385x360	875x385x360	875x385x360	875x385x360	
Net weight		kg	9	9	10	10	
Gross weight		kg	11	11	12	12	
Throttle		Type	Electromagnetic expansion valve				
Refrigerant		Type	R410A or R32				
Pipe diameter - liquid side		mm	6,4	6,4	6,4	6,4	
Pipe diameter - gas side		mm	12,7	12,7	12,7	12,7	
Pipe diameter - drainage		mm	16	16	16	16	
Set temperature range		°C	17-30	17-30	17-30	17-30	
ADDITIONAL TECHNICAL INFORMATION							
Communication cable		mm²	3x0,75 shielded in case mixed IDU SDV6 and SDV6 or 2x0,75 in case only IDU SDV6				
Recommended power cable		mm²	3x2,5	3x2,5	3x2,5	3x2,5	
Recommended air switch		A	B16	B16	B16	B16	
EQUIPMENT							
Drain pump			no	no	no	no	
Max. lift (from bottom of ID)		mm	-	-	-	-	
Alarm connector			yes (230V)	yes (230V)	yes (230V)	yes (230V)	
ON/OFF connector			yes (dry-contact)	yes (dry-contact)	yes (dry-contact)	yes (dry-contact)	
Fresh air inlet			no	no	no	no	
Left/Right louver**			no	no	no	no	
OPTIONAL ACCESSORIES							
Remote controller (IR)			SRC-61, RM05B***				
Wire controller			SWC-61, SWC-86ED***				
Group controller			SWC-61, SWC-62, SWC-63				
Wire controller - weekly timer, WiFi			SWC-62, SWC-63				
Central controller*			CCM-180A, CCM-270A, SCC-61, SDV6-CLOUD				
BMS gateway			SDV5-MOD*, SDV5-BAC*, SDV6-MOD*, SDV6-BAC*, KNX-03				

The specification of products is subject to change based on further development of the units by the producer and can be changed without prior notice. Refer to rating label. Conditions under which has been performed measurements of technical parameters see last page.

* Connect to ODU SDV6 or ODU SDV5. SDV6-BAC and SDV6-MOD only support connection to ODU SDV6.

** SDV6-HxxS is equipped with L+R louver.

*** Limited function.

Electrical connection scheme for power supply, communication and controller connection see page 42.

APPEARANCE AND DIMENSIONS OF INDOOR UNIT

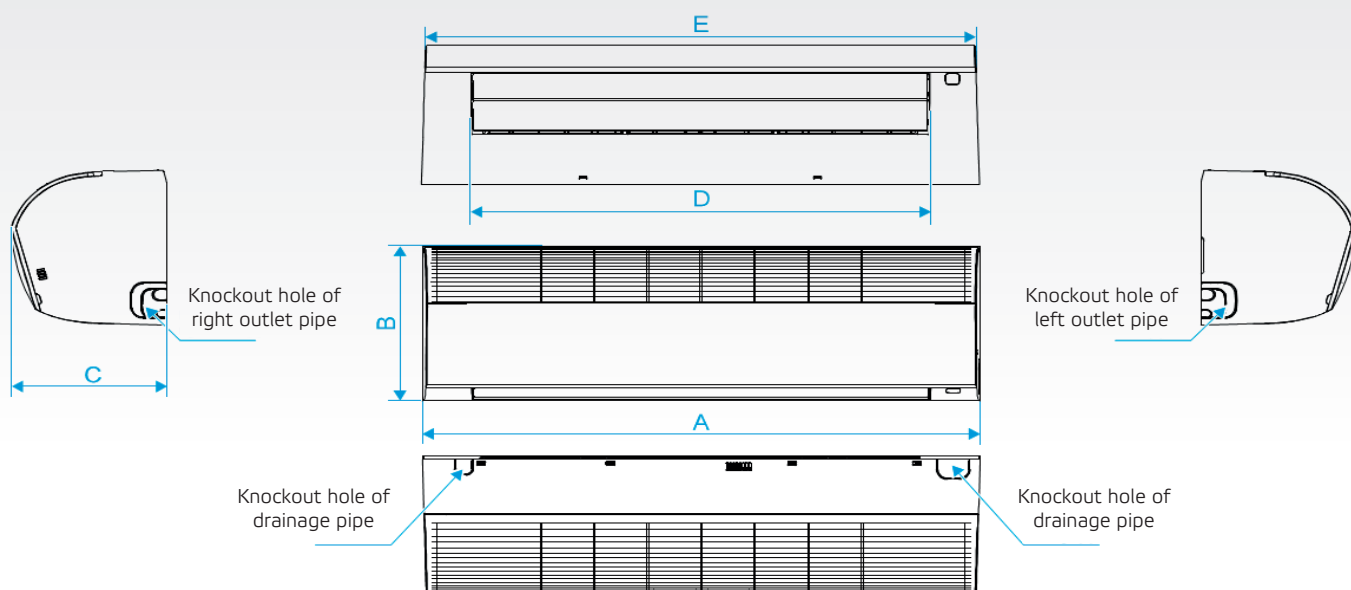

INDOOR UNITS

SDV6 WALL-MOUNTED

MODEL			SDV6-H45(S)	SDV6-H56(S)	SDV6-H71(S)	SDV6-H80(S)	
Capacity cooling/heating		kW	4,5/5,0	5,6/6,3	7,1/8,0	8,0/9,0	
Power supply		phase / Hz / V	1 ~ / 50 / 220-240	1 ~ / 50 / 220-240	1 ~ / 50 / 220-240	1 ~ / 50 / 220-240	
Power input		W	30	40	50	65	
Air flow of ID	SH/MH/H/M/L/ ML/SL	m³/h	720/670/620/560/ 510/460/410	860/780/700/620/ 550/480/410	1220/1120/1030/940/ 850/750/660	1380/1260/1140/1020/ 900/780/660	
Sound pressure level at 1m		dB(A)	37/35/33/32/31/30/29	41/39/37/35/33/31/29	44/42/40/38/36/34/32	45/43/41/39/37/35/32	
Sound power level		dB(A)	54/52/50/49/48/46/44	56/54/52/50/48/46/44	58/56/54/52/50/48/46	60/57/55/53/50/48/46	
Net dimensions	w x h x d	mm	950x295x265	950x295x265	1200x295x265	1200x295x265	
Packing dimensions	w x h x d	mm	1075x385x360	1075x385x360	1315x385x360	1315x385x360	
Net weight		kg	11,5	11,5	15	15	
Gross weight		kg	14	14	18	18	
Throttle		Type	Electromagnetic expansion valves				
Refrigerant		Type	R410A or R32				
Pipe diameter - liquid side		mm	6,4	9,5	9,5	9,5	
Pipe diameter - gas side		mm	12,7	15,9	15,9	15,9	
Pipe diameter - drainage		mm	16	16	16	16	
Set temperature range		°C	17-30	17-30	17-30	17-30	
ADDITIONAL TECHNICAL INFORMATION							
Communication cable		mm²	3x0,75 shielded in case mixed IDU SDV6 and SDV6 or 2x0,75 in case only IDU SDV6				
Recommended power cable		mm²	3x2,5	3x2,5	3x2,5	3x2,5	
Recommended air switch		A	B16	B16	B16	B16	
EQUIPMENT							
Drain pump			no	no	no	no	
Max. lift. (from bottom of ID)		mm	-	-	-	-	
Alarm connector			yes (230V)	yes (230V)	yes (230V)	yes (230V)	
ON/OFF connector			yes (dry-contact)	yes (dry-contact)	yes (dry-contact)	yes (dry-contact)	
Fresh air inlet			no	no	no	no	
Left/Right louver**			no	no	no	no	
OPTIONAL ACCESSORIES							
Remote controller (IR)			SRC-61, RM05B***				
Wire controller			SWC-61, SWC-86ED***				
Group controller			SWC-61, SWC-62, SWC-63				
Wire controller - weekly timer, WiFi			SWC-62, SWC-63				
Central controller*			CCM-180A, CCM-270A, SCC-61, SDV6-CLOUD				
BMS gateway			SDV5-MOD*, SDV5-BAC*, SDV6-MOD*, SDV6-BAC*, KNX-03				

The specification of products is subject to change based on further development of the units by the producer and can be changed without prior notice. Refer to rating label. Conditions under which has been performed measurements of technical parameters see last page.

* Connect to ODU SDV6 or ODU SDV5. SDV6-BAC and SDV6-MOD only support connection to ODU SDV6.

** SDV6-HxxS is equipped with L+R louver.

*** Limited function.

Electrical connection scheme for power supply, communication and controller connection see page 42.

APPEARANCE AND DIMENSIONS OF INDOOR UNIT

Model (kW)	1,5-3,6	4,5-5,6	7,1-8
A (mm)	750	950	1200
B (mm)	295	295	295
C (mm)	265	265	265
D (mm)	581	781	1025
E (mm)	736	936	1186

SDV6 DUCT MEDIUM STATIC PRESSURE

MODEL			SDV6-DM15	SDV6-DM22	SDV6-DM28	SDV6-DM36	SDV6-DM45
Capacity cooling/heating		kW	1,5/1,8	2,2/2,6	2,8/3,2	3,6/4,0	4,5/5,0
Power supply		phase / Hz / V	1 ~ / 50 / 220-240	1 ~ / 50 / 220-240	1 ~ / 50 / 220-240	1 ~ / 50 / 220-240	1 ~ / 50 / 220-240
Power input		W	33	36	40	45	70
Air flow of ID	SH/MH/H/M/L/ ML/SL	m³/h	470/438/407/375/ 343/312/280	500/467/433/400/ 367/333/300	540/503/467/430/ 393/357/320	575/535/495/455/ 415/375/335	665/623/580/538/ 495/453/410
Sound pressure level at 1,4m		dB(A)	27/26/25/24/23/23/22	27/26/25/24/23/23/22	27/26/25/24/23/23/22	29/28/27/26/25/23/22	33/32/30/28/27/25/24
Sound power level		dB(A)	46/45/43/42/40/39/37	47/46/44/43/41/40/38	47/46/44/43/41/40/38	50/49/47/45/43/41/39	53/51/49/47/45/43/41
External static pressure	nom/min-max	Pa	30 (10-160)	30 (10-160)	30 (10-160)	30 (10-160)	30 (10-160)
Net dimensions	w x h x d	mm	710x245x770	710x245x770	710x245x770	710x245x770	710x245x770
Packing dimensions	w x h x d	mm	765x305x890	765x305x890	765x305x890	765x305x890	765x305x890
Net weight		kg	18,5	18,5	18,5	18,5	19,5
Gross weight		kg	21	21	21	21	22
Throttle		Type	Electromagnetic expansion valve				
Refrigerant		Type	R410A or R32				
Pipe diameter - liquid side		mm	6,4	6,4	6,4	6,4	6,4
Pipe diameter - gas side		mm	12,7	12,7	12,7	12,7	12,7
Pipe diameter - drainage		mm	25	25	25	25	25
Set temperature range		°C	17-30	17-30	17-30	17-30	17-30
ADDITIONAL TECHNICAL INFORMATION							
Screw holes distance		mm	645x630	645x630	645x630	645x630	645x630
Communication cable		mm²	3x0,75 shielded in case mixed IDU SDV6 and SDV6 or 2x0,75 in case only IDU SDV6				
Recommended power cable		mm²	3x2,5	3x2,5	3x2,5	3x2,5	3x2,5
Recommended air switch		A	B16	B16	B16	B16	B16
EQUIPMENT							
Drain pump			yes	yes	yes	yes	yes
Max. lift. (from bottom of ID)		mm	1200	1200	1200	1200	1200
Alarm connector			yes (230V)	yes (230V)	yes (230V)	yes (230V)	yes (230V)
ON/OFF connector			yes (dry-contact)	yes (dry-contact)	yes (dry-contact)	yes (dry-contact)	yes (dry-contact)
Fresh air inlet			yes (Φ100mm)	yes (Φ100mm)	yes (Φ100mm)	yes (Φ100mm)	yes (Φ100mm)
OPTIONAL ACCESSORIES							
Remote controller (IR)			SRC-61, RM05B***				
Wire controller			SWC-61, SWC-86ED***				
Group controller			SWC-61, SWC-62, SWC-63				
Wire controller - weekly timer, WiFi			SWC-62, SWC-63				
Central controller*			CCM-180A, CCM-270A, SCC-61, SDV6-CLOUD				
BMS gateway			SDV5-MOD*, SDV5-BAC*, SDV6-MOD*, SDV6-BAC*, KNX-03				

The specification of products is subject to change based on further development of the units by the producer and can be changed without prior notice. Refer to rating label.

Conditions under which has been performed measurements of technical parameters see last page.

* Connect to ODU SDV6 or ODU SDV5. SDV6-BAC and SDV6-MOD only support connection to ODU SDV6.

*** Limited function.

Electrical connection scheme for power supply, communication and controller connection see page 42.

INDOOR UNITS

SDV6 DUCT MEDIUM STATIC PRESSURE

MODEL			SDV6-DM56	SDV6-DM71	SDV6-DM80	SDV6-DM90	SDV6-DM112
Capacity cooling/heating		kW	5,6/6,3	7,1/8,0	8,0/9,0	9,0/10,0	11,2/12,5
Power supply		phase / Hz / V	1 ~ / 50 / 220-240	1 ~ / 50 / 220-240	1 ~ / 50 / 220-240	1 ~ / 50 / 220-240	1 ~ / 50 / 220-240
Power input		W	70	70	96	110	138
Air flow of ID	SH/MH/H/M/L/ ML/SL	m³/h	970/904/838/773/ 707/641/575	1150/1068/986/904/ 822/740/660	1355/1263/1172/1080/ 988/897/805	1420/1323/1225/1128/ 1030/933/835	1950/1817/1683/1550/ 1417/1283/1150
Sound pressure level at 1,4m		dB(A)	33/32/31/30/28/26/25	35/34/32/31/29/28/26	37/36/34/33/31/30/28	37/36/34/33/31/30/28	39/37/35/33/31/29/28
Sound power level		dB(A)	55/53/51/49/47/45/43	58/56/54/52/48/47/45	59/57/55/53/51/49/47	59/57/55/53/51/48/46	60/58/57/55/54/52/50
External static pressure	nom/min-max	Pa	30 (10-160)	30 (10-160)	40 (10-160)	40 (10-160)	40 (10-160)
Net dimensions	w x h x d	mm	910x245x770	910x245x770	1160x245x770	1160x245x770	1510x245x770
Packing dimensions	w x h x d	mm	965x305x890	965x305x890	1215x305x890	1215x305x890	1565x305x890
Net weight		kg	24	25	30	31	37
Gross weight		kg	27,5	28,5	33,5	34,5	41,5
Throttle		Type	Electromagnetic expansion valve				
Refrigerant		Type	R410A or R32				
Pipe diameter - liquid side		mm	9,5	9,5	9,5	9,5	9,5
Pipe diameter - gas side		mm	15,9	15,9	15,9	15,9	15,9
Pipe diameter - drainage		mm	25	25	25	25	25
Set temperature range		°C	17-30	17-30	17-30	17-30	17-30
ADDITIONAL TECHNICAL INFORMATION							
Screw holes distance		mm	845x630	845x630	1095x630	1095x630	1095x630
Communication cable		mm²	3x0,75 shielded in case mixed IDU SDV6 and SDV6 or 2x0,75 in case only IDU SDV6				
Recommended power cable		mm²	3x2,5	3x2,5	3x2,5	3x2,5	3x2,5
Recommended air switch		A	B16	B16	B16	B16	B16
EQUIPMENT							
Drain pump			yes	yes	yes	yes	yes
Max. lift. (from bottom of ID)		mm	1200	1200	1200	1200	1200
Alarm connector			yes (230V)	yes (230V)	yes (230V)	yes (230V)	yes (230V)
ON/OFF connector			yes (dry-contact)	yes (dry-contact)	yes (dry-contact)	yes (dry-contact)	yes (dry-contact)
Fresh air inlet			yes (Φ100mm)	yes (Φ100mm)	yes (Φ100mm)	yes (Φ100mm)	yes (Φ100mm)
OPTIONAL ACCESSORIES							
Remote controller (IR)			SRC-61, RM05B***				
Wire controller			SWC-61, SWC-86ED***				
Group controller			SWC-61, SWC-62, SWC-63				
Wire controller - weekly timer, WiFi			SWC-62, SWC-63				
Central controller*			CCM-180A, CCM-270A, SCC-61, SDV6-CLOUD				
BMS gateway			SDV5-MOD*, SDV5-BAC*, SDV6-MOD*, SDV6-BAC*, KNX-03				

The specification of products is subject to change based on further development of the units by the producer and can be changed without prior notice. Refer to rating label.

Conditions under which has been performed measurements of technical parameters see last page.

* Connect to ODU SDV6 or ODU SDV5. SDV6-BAC and SDV6-MOD only support connection to ODU SDV6.

*** Limited function.

Electrical connection scheme for power supply, communication and controller connection see page 42.

SDV6 DUCT MEDIUM STATIC PRESSURE

MODEL			SDV6-DM125	SDV6-DM140	SDV6-DM160		
Capacity cooling/heating		kW	12,5/14,0	14,0/16,0	16,0/18,0		
Power supply		phase / Hz / V	1 ~ / 50 / 220-240	1 ~ / 50 / 220-240	1 ~ / 50 / 220-240		
Power input		W	172	172	210		
Air flow of ID	SH/MH/H/M/L/ ML/SL	m ³ /h	2105/1971/1837/1703/ 1568/1434/1300	2105/1971/1837/1703/ 1568/1434/1300	2350/2160/2015/1871/ 1776/1533/1400		
Sound pressure level at 1,4m		dB(A)	40/38/36/34/32/30/29	40/38/36/34/32/30/29	42/40/38/36/34/33/31		
Sound power level		dB(A)	64/62/62/60/58/55/53	64/62/62/60/58/55/53	65/63/61/59/57/54/52		
External static pressure	nom/min-max	Pa	50 (10-160)	50 (10-160)	50 (10-160)		
Net dimensions	w x h x d	mm	1510x245x770	1510x245x770	1510x245x770		
Packing dimensions	w x h x d	mm	1565x305x890	1565x305x890	1565x305x890		
Net weight		kg	39	39	39		
Gross weight		kg	43,5	43,5	43,5		
Throttle		Type	Electromagnetic expansion valve				
Refrigerant		Type	R410A or R32				
Pipe diameter - liquid side		mm	9,5	9,5	9,5		
Pipe diameter - gas side		mm	15,9	15,9	15,9		
Pipe diameter - drainage		mm	25	25	25		
Set temperature range		°C	17-30	17-30	17-30		
ADDITIONAL TECHNICAL INFORMATION							
Screw holes distance		mm	1095x630	1445x630	1445x630		
Communication cable		mm ²	3x0,75 shielded in case mixed IDU SDV6 and SDV6 or 2x0,75 in case only IDU SDV6				
Recommended power cable		mm ²	3x2,5	3x2,5	3x2,5		
Recommended air switch		A	B16	B16	B16		
EQUIPMENT							
Drain pump			yes	yes	yes		
Max. lift (from bottom of ID)		mm	1200	1200	1200		
Alarm connector			yes (230V)	yes (230V)	yes (230V)		
ON/OFF connector			yes (dry-contact)	yes (dry-contact)	yes (dry-contact)		
Fresh air inlet			yes (Φ100mm)	yes (Φ100mm)	yes (Φ100mm)		
OPTIONAL ACCESSORIES							
Remote controller (IR)			SRC-61, RM05B***				
Wire controller			SWC-61, SWC-86ED***				
Group controller			SWC-61, SWC-62, SWC-63				
Wire controller - weekly timer, WiFi			SWC-62, SWC-63				
Central controller*			CCM-180A, CCM-270A, SCC-61, SDV6-CLOUD				
BMS gateway			SDV5-MOD*, SDV5-BAC*, SDV6-MOD*, SDV6-BAC*, KNX-03				

The specification of products is subject to change based on further development of the units by the producer and can be changed without prior notice. Refer to rating label.

Conditions under which has been performed measurements of technical parameters see last page.

* Connect to ODU SDV6 or ODU SDV5. SDV6-BAC and SDV6-MOD only support connection to ODU SDV6.

*** Limited function.

Electrical connection scheme for power supply, communication and controller connection see page 42.

APPEARANCE AND DIMENSIONS OF INDOOR UNIT

SDV6 DUCT MEDIUM STATIC PRESSURE

External dimension, air outlet size, and size of fresh air outlet:

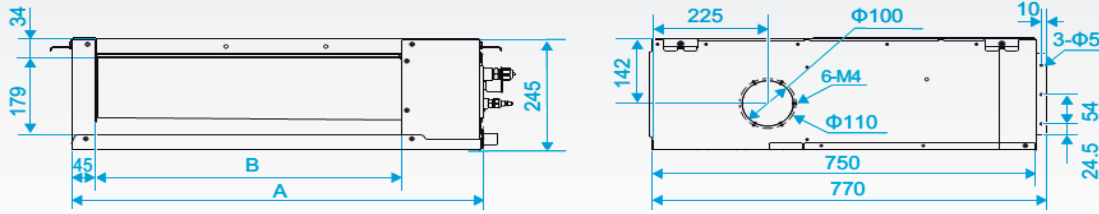

Size of return air inlet (back return air mode):

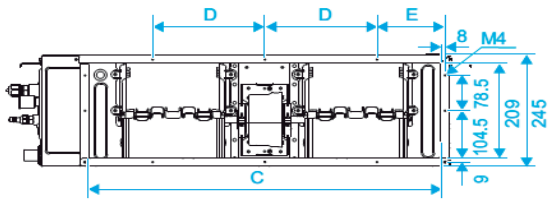

Dimension of pipe and water pipe:

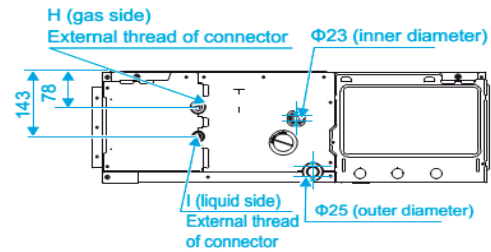

Size of return air inlet (bottom return air mode), and the distance between the lugs:

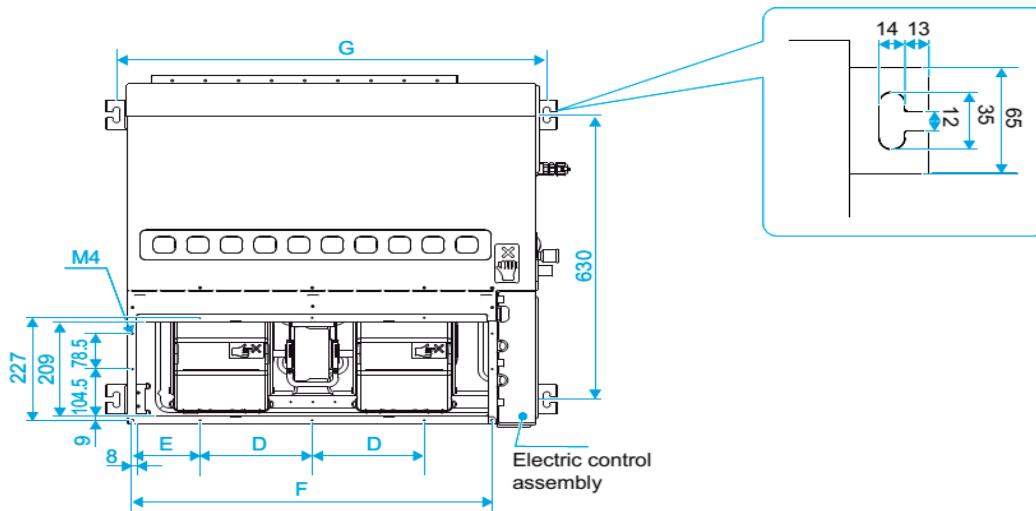

Model	1,5-4,5	5,6	7,1	8-11,2	12,5-16
A (mm)	600	800	800	1050	1400
B (mm)	400	600	600	850	1200
C (mm)	490	690	690	940	1290
D (mm)	87,5	220	220	220	220
E (mm)	165	134	134	146	213
G (mm)	645	845	845	1095	1445
H (mm)	3/4-16 UNF	3/4-16 UNF	7/8-11 UNF	7/8-11 UNF	7/8-11 UNF
I (mm)	7/16-20 UNF	7/16-20 UNF	5/8-18 UNF	5/8-18 UNF	5/8-18 UNF

INDOOR UNITS

SDV6 FLOOR/CEILING

MODEL			SDV6-F36	SDV6-F45	SDV6-F56	SDV6-F71	SDV6-F80
Capacity cooling/heating		kW	3,6/4,0	4,5/5,0	5,6/6,3	7,1/8,0	8,0/9,0
Power supply		phase / Hz / V	1 ~ / 50 / 220-240	1 ~ / 50 / 220-240	1 ~ / 50 / 220-240	1 ~ / 50 / 220-240	1 ~ / 50 / 220-240
Power input		W	16	24	40	42	56
Air flow of ID	SH/MH/H/M/L/ ML/SL	m³/h	564/539/514/492/ 467/445/424	712/674/637/603/ 565/531/500	927/883/840/794/ 751/707/665	1128/1062/1024/926/ 860/791/729	1300/1218/1138/1057/ 982/904/824
Sound pressure level at 1,4m		dB(A)	32/30/29/28/27/26/25	36/35/34/33/32/31/30	43/41/40/38/36/34/33	43/40/39/37/35/34/33	45/44/42/40/38/36/34
Sound power level		dB(A)	43/42/40/39/38/38/37	47/45/45/43/42/41/40	54/53/51/50/48/47/45	54/53/52/51/49/48/48	55/53/51/50/49/46/44
Net dimensions	w x h x d	mm	1069x674x234	1069x674x234	1069x674x234	1284x674x234	1284x674x234
Packing dimensions	w x h x d	mm	1190x755x313	1190x755x313	1190x755x313	1405x755x323	1405x755x323
Net weight		kg	24,7	24,7	24,7	29,8	29,8
Gross weight		kg	29,5	29,5	29,5	34,8	34,8
Throttle		Type	Electromagnetic expansion valve				
Refrigerant		Type	R410A or R32				
Pipe diameter - liquid side		mm	6,4	6,4	9,5	9,5	9,5
Pipe diameter - gas side		mm	12,7	12,7	15,9	15,9	15,9
Pipe diameter - drainage		mm	25	25	25	25	25
Set temperature range		°C	17-30	17-30	17-30	17-30	17-30
ADDITIONAL TECHNICAL INFORMATION							
Screw holes distance		mm	984x221	984x221	984x221	1199x221	1199x221
Communication cable		mm²	3x0,75 shielded in case mixed IDU SDV6 and SDV6 or 2x0,75 in case only IDU SDV6				
Recommended power cable		mm²	3x2,5	3x2,5	3x2,5	3x2,5	3x2,5
Recommended air switch		A	B16	B16	B16	B16	B16
EQUIPMENT							
Drain pump			no	no	no	no	no
Max. lift (from bottom of ID)		mm	-	-	-	-	-
Alarm connector			yes (230V)	yes (230V)	yes (230V)	yes (230V)	yes (230V)
ON/OFF connector			yes (dry-contact)	yes (dry-contact)	yes (dry-contact)	yes (dry-contact)	yes (dry-contact)
Fresh air inlet			no	no	no	no	no
OPTIONAL ACCESSORIES							
Remote controller (IR)			SRC-61, RM05B***				
Wire controller			SWC-61, SWC-86ED***				
Group controller			SWC-61, SWC-62, SWC-63				
Wire controller - weekly timer, WiFi			SWC-62, SWC-63				
Central controller*			CCM-180A, CCM-270A, SCC-61, SDV6-CLOUD				
BMS gateway			SDV5-MOD*, SDV5-BAC*, SDV6-MOD*, SDV6-BAC*, KNX-03				

The specification of products is subject to change based on further development of the units by the producer and can be changed without prior notice. Refer to rating label.

Conditions under which has been performed measurements of technical parameters see last page.

* Connect to ODU SDV6 or ODU SDV5. SDV6-BAC and SDV6-MOD only support connection to ODU SDV6.

*** Limited function.

Electrical connection scheme for power supply, communication and controller connection see page 42.

APPEARANCE AND DIMENSIONS OF INDOOR UNIT

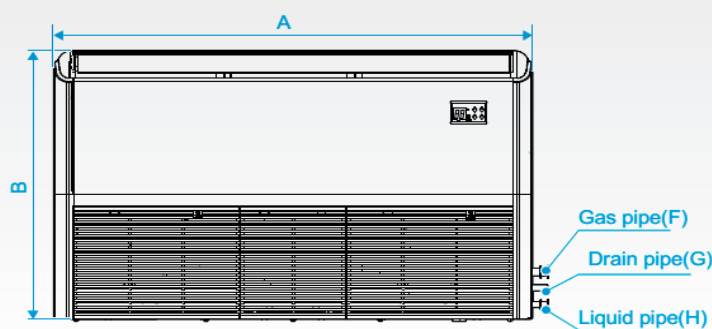

Model	3,6-5,6	7,1-9,0	10,0-14,0
A (mm)	1069	1284	1649
B (mm)	674	674	674
C (mm)	234	234	234
D (mm)	984	1199	1565
E (mm)	221	221	221
F (mm)	Φ12,7	Φ15,9	Φ15,9
G (mm)	Φ25	Φ25	Φ25
H (mm)	Φ6,4	Φ9,5	Φ9,5

INDOOR UNITS

SDV6 FLOOR/CEILING

MODEL			SDV6-F90	SDV6-F100	SDV6-F112	SDV6-F125	SDV6-F140
Capacity cooling/heating		kW	9,0/10,0	10,0/11,2	11,2/12,5	12,5/14,0	14,0/16,0
Power supply		phase / Hz / V	1 ~ / 50 / 220-240	1 ~ / 50 / 220-240	1 ~ / 50 / 220-240	1 ~ / 50 / 220-240	1 ~ / 50 / 220-240
Power input		W	75	50	65	95	140
Air flow of ID	SH/MH/H/M/L/ ML/SL	m³/h	1480/1397/1302/1218/ 1138/1056/979	1497/1469/1296/1200/ 1104/1015/918	1648/1530/1469/1292/ 1178/1067/956	2012/1879/1772/1649/ 1531/1469/1285	2206/2070/1937/1810/ 1677/1516/1402
Sound pressure level at 1,4m		dB(A)	48/47/46/44/42/40/37	42/40/39/37/35/33/32	44/42/41/39/37/35/33	49/48/46/44/42/40/38	52/50/48/46/44/42/40
Sound power level		dB(A)	58/57/55/54/52/50/49	54/53/51/50/48/46/44	56/54/53/51/49/47/45	60/59/58/56/54/53/51	63/62/60/58/56/54/53
Net dimensions	w x h x d	mm	1284x674x234	1649x674x234	1649x674x234	1649x674x234	1649x674x234
Packing dimensions	w x h x d	mm	1405x755x323	1770x755x323	1770x755x323	1770x755x323	1770x755x323
Net weight		kg	29,8	36,4	36,4	36,4	36,4
Gross weight		kg	34,8	42,7	42,7	42,7	42,7
Throttle		Type	Electromagnetic expansion valve				
Refrigerant		Type	R410A or R32				
Pipe diameter - liquid side		mm	9,5	9,5	9,5	9,5	9,5
Pipe diameter - gas side		mm	15,9	15,9	15,9	15,9	15,9
Pipe diameter - drainage		mm	25	25	25	25	25
Set temperature range		°C	17-30	17-30	17-30	17-30	17-30
ADDITIONAL TECHNICAL INFORMATION							
Screw holes distance		mm	1199x221	1565x221	1565x221	1565x221	1565x221
Communication cable		mm²	3x0,75 shielded in case mixed IDU SDV6 and SDV6 or 2x0,75 in case only IDU SDV6				
Recommended power cable		mm²	3x2,5	3x2,5	3x2,5	3x2,5	3x2,5
Recommended air switch		A	B16	B16	B16	B16	B16
EQUIPMENT							
Drain pump			no	no	no	no	no
Max. lift (from bottom of ID)		mm	-	-	-	-	-
Alarm connector			yes (230V)	yes (230V)	yes (230V)	yes (230V)	yes (230V)
ON/OFF connector			yes (dry-contact)	yes (dry-contact)	yes (dry-contact)	yes (dry-contact)	yes (dry-contact)
Fresh air inlet			no	no	no	no	no
OPTIONAL ACCESSORIES							
Remote controller (IR)			SRC-61, RM05B***				
Wire controller			SWC-61, SWC-86ED***				
Group controller			SWC-61, SWC-62, SWC-63				
Wire controller - weekly timer, WiFi			SWC-62, SWC-63				
Central controller*			CCM-180A, CCM-270A, SCC-61, SDV6-CLOUD				
BMS gateway			SDV5-MOD*, SDV5-BAC*, SDV6-MOD*, SDV6-BAC*, KNX-03				

The specification of products is subject to change based on further development of the units by the producer and can be changed without prior notice. Refer to rating label.

Conditions under which has been performed measurements of technical parameters see last page.

* Connect to ODU SDV6 or ODU SDV5. SDV6-BAC and SDV6-MOD only support connection to ODU SDV6.

*** Limited function.

Electrical connection scheme for power supply, communication and controller connection see page 42.

APPEARANCE AND DIMENSIONS OF INDOOR UNIT

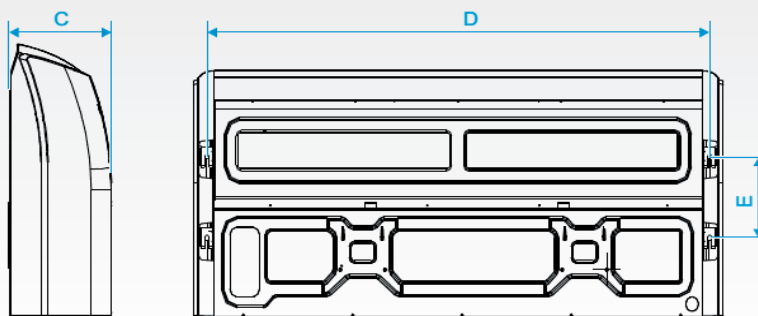

COMPATIBLE WITH OD SDV4, SDV4F, SDV5, SDV5-3P, SDV6 R410A

MODEL			AHUKZ-00D	AHUKZ-01D	AHUKZ-02D	AHUKZ-03D
Capacity		kW	2,2-8	9-20	21-36	37-56
Power supply		phase / Hz / V	1 ~ / 50 / 220-240	1 ~ / 50 / 220-240	1 ~ / 50 / 220-240	1 ~ / 50 / 220-240
Net dimensions	w x d x h	mm	393x341x125	393x341x125	393x341x125	393x341x125
Packing dimensions	w x d x h	mm	490x440x205	490x440x205	490x440x205	490x440x205
Net weight		kg	5,6	5,6	5,9	6
Gross weight		kg	8,6	8,6	8,8	8,9
Throttle		Type	EXV	EXV	EXV	EXV
Design pressure	H/L	MPa	4,4/2,6	4,4/2,6	4,4/2,6	4,4/2,6
Refrigerant type		Type	R410A	R410A	R410A	R410A
Pipe diameter - Liquid in side		mm	Φ8	Φ8	Φ12,7	Φ15,9
Pipe diameter - Liquid out side		mm	Φ8	Φ8	Φ12,7	Φ15,9
ADDITIONAL TECHNICAL INFORMATION						
Screw holes distance	w x d	mm	250x330	250x330	250x330	250x330
Communication cable		mm ²	3x0,75 shielded	3x0,75 shielded	3x0,75 shielded	3x0,75 shielded
Recommended power cable		mm ²	3x2,5	3x2,5	3x2,5	3x2,5
Recommended air switch		A	B16	B16	B16	B16
EQUIPMENT						
Run status			yes	yes	yes	yes
Defrost status			yes	yes	yes	yes
Alarm connector			yes	yes	yes	yes
ON/OFF connector			yes	yes	yes	yes
External control			0-10V (related to indoor temp. setting with 0,5V steps or related to capacity setting continuous control 0-100%)			
STANDARD ACCESSORIES						
Wire controller			SWC-86ED	SWC-86ED	SWC-86ED	SWC-86ED
Temp. sensor T1, TA, T2A, T2, T2B			yes	yes	yes	yes

The specification of products is subject to change based on further development of the units by the producer and can be changed without prior notice. Refer to rating label.

R410 (50% HFC-32, 50% HFC-125), GWP of refrigerant used: 2088.

Contains fluorinated greenhouse gases covered by the Kyoto Protocol.

Conditions under which has been performed measurements of technical parameters see last page.

APPEARANCE AND DIMENSIONS OF AHU KIT

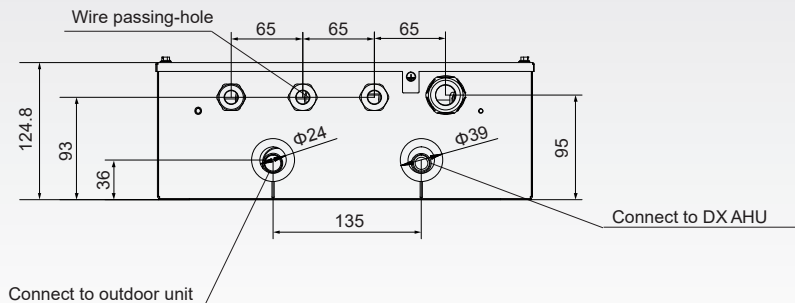

INSTALLATION WITH SEPARATED EXV

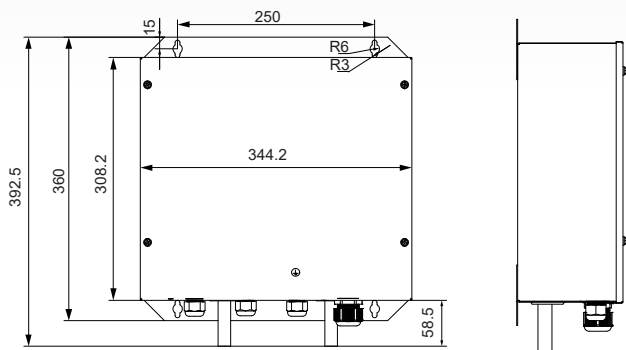
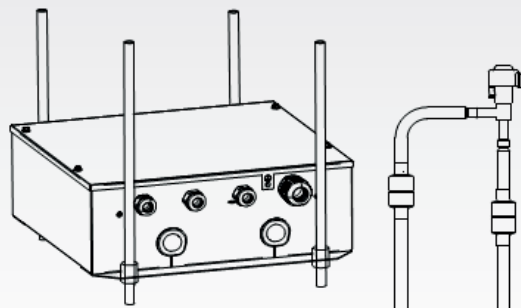

COMPATIBLE WITH OD SDV4, SDV4F, SDV5, SDV5-3P, SDV6 R410A

**Wiring signal wires
Terminal block for signal wires**

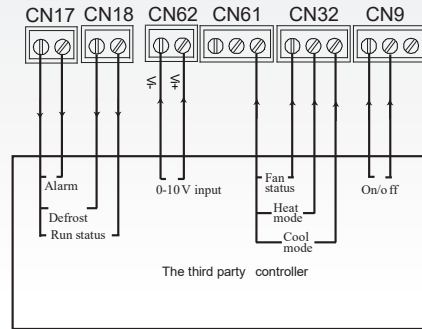
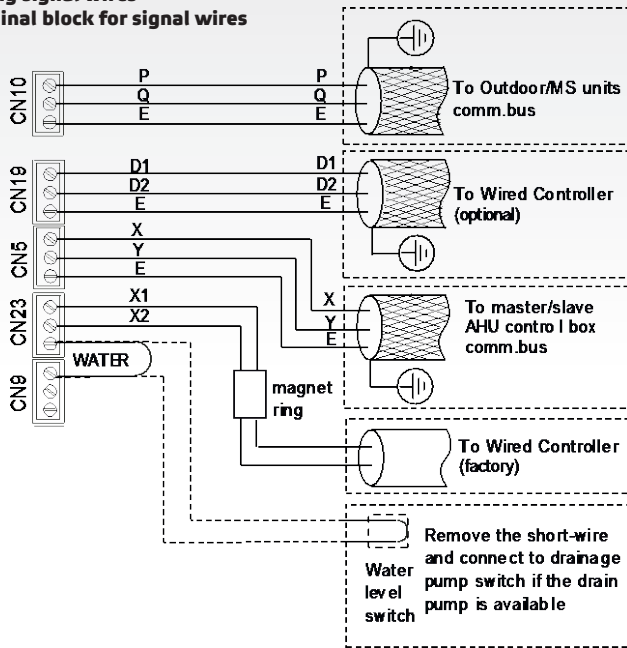

Controller selection

SW4-1

Method of control

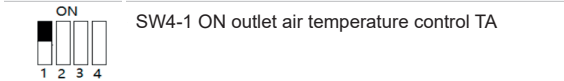
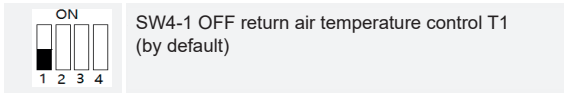

Method of control

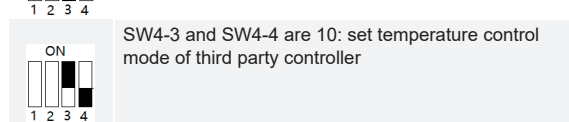
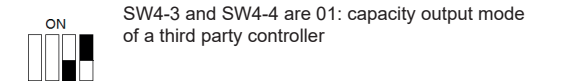
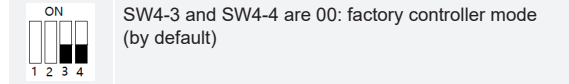

EXAMPLE OF TEMPERATURE SENSOR INSTALLING AND WIRING

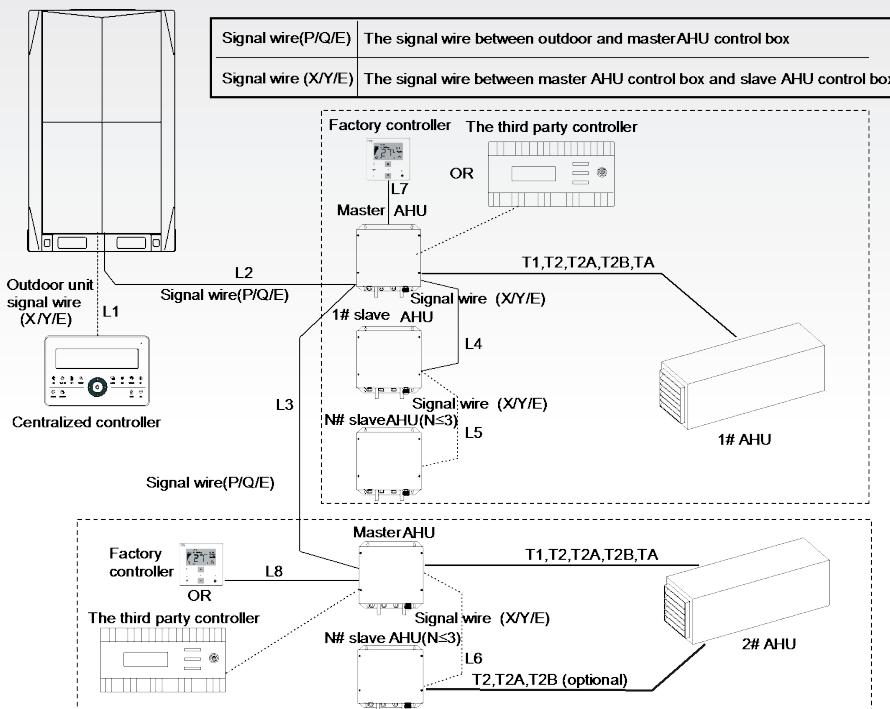

EXTERNAL CONTROL OF AHU KIT

The definition of signal between the third party controller and AHU control box

Signals from the third party controller to AHU control box

Signal	Signal Type	Specification	Port
Capacity set	Analog voltage	0-10VDC	0-10V
ON/OFF	Dry contact	Close: ON Disconnect: OFF	ON/OFF
Cool mode	Dry contact	Close: cool mode Disconnect: no cool signal	COOL
Heat mode	Dry contact	Close: heat mode Disconnect: no heat signal	HEAT
Fan status	Dry contact	Close: fan ON Disconnect: fan OFF	FAN

Signals from AHU control box to the third party controller

Signal	Signal Type	Specification	Port
Alarm	Dry contact	Close: no alarm Disconnect: alarm	ALARM
Defrost	Dry contact	Close: defrosting Disconnect: no defrost	Defrost
Run status	Dry contact	Close: running Disconnect: off	Run

ANALOG VOLTAGE CONTROL

Based on return air temperature T1

Third party controller - return air temperature control settings				
Normal (V)	Voltage Range (V)		Cooling Set Temperature (°C)	Heating Set Temperature (°C)
	Min.	Max.		
0.5	0	0.75	Not available	Not available
1	0.85	1.15	17	17
1.4	1.25	1.55	17	17
1.8	1.65	1.95	17	17
2.2	2.05	2.35	17	17
2.6	2.45	2.75	17	17
3	2.85	3.15	17	17
3.4	3.25	3.55	17	17
3.8	3.65	3.95	17	17
4.2	4.05	4.35	18	18
4.6	4.45	4.75	19	19
5	4.85	5.15	20	20
5.4	5.25	5.55	21	21
5.8	5.65	5.95	22	22
6.2	6.05	6.35	23	23
6.6	6.45	6.75	24	24
7	6.85	7.15	25	25
7.4	7.25	7.55	26	26
7.8	7.65	7.95	27	27
8.2	8.05	8.35	28	28
8.6	8.45	8.75	29	29
9	8.85	9.15	30	30
9.4	9.25	10	Not available	Not available

ANALOG VOLTAGE CONTROL

Based on outdoor unit capacity - setting 0-100% (possible to use T1 or TA)

Capacity Setting requirement table (Same in Heating and Cooling)		
Analog input 0-10V DC		Capacity Setting Requirement
Normal (V)	Range (V)	
0	$U < 0.5$	0%
1	$0.5 \leq U < 1.5$	10%
2	$1.5 \leq U < 2.5$	20%
3	$2.5 \leq U < 3.5$	30%
4	$3.5 \leq U < 4.5$	40%
5	$4.5 \leq U < 5.5$	50%
6	$5.5 \leq U < 6.5$	60%
7	$6.5 \leq U < 7.5$	70%
8	$7.5 \leq U < 8.5$	80%
9	$8.5 \leq U < 9.5$	90%
10	$9.5 \leq U < 10$	100%

Based on outlet air temperature TA

Third party controller - outlet air temperature control settings				
Normal (V)	Voltage Range (V)		Cooling Set Temperature (°C)	Heating Set Temperature (°C)
	Min.	Max.		
0.5	0	0.75	Not settable	Not settable
1	0.85	1.15	10	10
1.4	1.25	1.55	11	11
1.8	1.65	1.95	12	12
2.2	2.05	2.35	13	13
2.6	2.45	2.75	14	14
3	2.85	3.15	15	15
3.4	3.25	3.55	16	16
3.8	3.65	3.95	17	17
4.2	4.05	4.35	18	18
4.6	4.45	4.75	19	19
5	4.85	5.15	20	20
5.4	5.25	5.55	21	21
5.8	5.65	5.95	22	22
6.2	6.05	6.35	23	23
6.6	6.45	6.75	24	24
7	6.85	7.15	25	25
7.4	7.25	7.55	26	26
7.8	7.65	7.95	27	27
8.2	8.05	8.35	28	28
8.6	8.45	8.75	29	29
9	8.85	9.15	30	30
9.4	9.25	10	Not settable	Not settable

REMOTE AND WIRED CONTROLLERS COMPATIBLE WITH ID SDV6

MODEL		RM05B	SRC-61	SWC-86ED	SWC-61	SWC-120G	SWC-62	SWC-63
On/Off		yes	yes	yes	yes	yes	yes	yes
Mode selection		yes	yes	yes	yes	yes	yes	yes
Temperature setting		yes	yes	yes	yes	yes	yes	yes
7-speed fan control		yes	yes	yes	yes	yes	yes	yes
Auto swing		yes	yes	yes	yes	yes	yes	yes
5-step swing louver		yes	yes	yes	yes	yes	yes	yes
Separate louver control (only cassette)		no	yes	no	no	no	yes	yes
Address setting		yes	yes	yes	yes	yes	yes	yes
Follow me		no	no	yes	yes	yes	yes	yes
Eco mode		yes	yes	yes	yes	yes	yes	yes
Room temperature display		no	no	yes	yes	yes	yes	yes
°F / °C display		no	no	yes	yes	yes	yes	yes
Keyboard lock		yes	yes	yes	yes	yes	yes	yes
Background light		yes	yes	yes	yes	yes	yes	yes
Daily timer		yes	yes	yes	yes	yes	yes	yes
Weekly schedule timer		no	no	no	no	yes	yes	yes
Auto restart		no	no	yes	yes	yes	yes	yes
2 permission levels		no	no	no	no	yes	yes	yes
Bi-directional communication		no	no	yes	yes	yes	yes	yes
Group control		no	no	no	yes	no	yes	yes
Individual control in case a group		no	no	no	no	no	yes	yes
Main or secondary controller setting		no	no	yes	yes	yes	yes	yes
Display IDU shut-off		yes	yes	yes	yes	yes	yes	yes
Night silent mode		yes	yes	yes	yes	yes	yes	yes
Remote signal receiver		no	no	yes	yes	yes	yes	yes
Clean filter reminder		no	no	yes	yes	yes	yes	yes
Clock display		no	no	no	no	yes	yes	yes
Color display		no	no	no	no	no	yes	yes
Error check function		no	no	yes	yes	yes	yes	yes
System parameter quering		no	no	yes	yes	yes	yes	yes
System setting control		no	no	yes	yes	yes	yes	yes
Wifi control		no	no	no	no	no	yes	yes
Dimension	wxdxh	150x65x20	170x47x25	86x86x18	86x86x18	120x120x20	86x86x18	120x120x18
Power supply	V	1,5 (AAA)x2	1,5 (AAA)x2	DC 18	DC 18	DC 18	DC 18	DC 18



CENTRAL CONTROLLERS COMPATIBLE WITH SDV6

MODEL		SDV6-CLOUD	CCM-180A	CCM-270A	SCC-61
Max. number of ID		64	64	384	384
Max. number of OD		-	32	192	192
Max. number of ref. systems		-	8	48	48
Touch screen	inch	-	6,2	10,1	10,1
On/Off		yes	yes	yes	yes
Mode selection		yes	yes	yes	yes
Temperature setting	°C	yes (0,5 steps)	yes (0,5 steps)	yes (0,5 steps)	yes (0,5 steps)
7-speed fan control		yes	yes	yes	yes
Auto swing		yes	yes	yes	yes
Room temperature display		yes	yes	yes	yes
OD eco mode setting		yes	yes	yes	yes
Holiday setting		yes	yes	yes	yes
°F / °C display		yes	yes	yes	yes
Schedule management		yes	yes	yes	yes
Clock display		-	yes	yes	yes
2 permission levels		yes	yes	yes	yes
Unit model recognition		yes	yes	yes	yes
Electricity charge distribution		no	no	yes**	yes**
Visual schematic		no	no	no	yes
Energy management		no	no	yes	yes
Group management		yes	yes	yes	yes
Error check function		yes	yes	yes	yes
System parameter querying		yes	yes	yes	yes
USB output		no	yes	yes	yes
Report display		Error report	Error report	Error report, operation record and electricity consumption** report	Error report, operation record and electricity consumption** report
Operation log		yes	no	yes	yes
Emergency stop signal		yes (dry-contact)	no	no	no
LAN access		yes	no	yes	yes
Mobile application		yes (android, iOS)	no	no	no
Connection to ODU		SDV5, SDV6	SDV5, SDV6*	SDV5, SDV6*	SDV6
Supported languages		English	English	English	English
Dimension	w x d x h	187x115x27	115x117x34	270x183x27	270x183x27
Power supply	V	DC 5	DC 12	DC 24***	DC 24***

* Require to set on ODU protocol SDV5.

** Require digital energy meter SEM-01.

*** Not in a package, needs to be used adapter from field DC 24V, 1A
Add SDV6-EK kit to the outdoor unit in case you need to connect 2 central controllers or 1 central controller with BMS control.



BMS GATEWAY COMPATIBLE WITH SDV6

MODEL		GW-BAC*	SDV6-BAC	SDV5-MOD*	SDV6-MOD	KNX-03
Max. number of ID		256	64*3	64	64	1
Max. number of OD		96	24*3	24	24	-
Max. number of ref. systems		32	8*3	8	8	-
On/Off		yes	yes	yes	yes	yes
Mode selection		yes	yes	yes	yes	yes
Temperature setting		yes	yes	yes	yes	yes
Fan speed		yes	yes	yes	yes	yes
Group shut down		no	no	no	no	no
Energy management		no	no	no	no	no
Room temperature display		yes	yes	yes	yes	no
Error status		no	no	yes	yes	yes
Error alarms		yes	yes	no	no	no
Operating mode of OD		yes	yes	yes	yes	no
Outdoor ambient temperature		yes	yes	yes	yes	no
Fan speed of OD		yes	yes	yes	yes	no
Compressor operating frequency		yes	yes	no	no	no
Discharge temperature		yes	yes	no	no	no
System pressure		yes	yes	no	no	no
Error status of OD		yes	yes	yes	yes	no
Error alarms of OD		yes	yes	no	no	no
LAN access		yes	yes	yes	yes	no
BTL certification		yes	yes	no	no	no
Dimension	w x d x h	190x116x67	154x124x52	225x128x28	154x124x52	85x51x16
Power supply	V	DC 24***	DC 24***	DC 12	DC 12	-

* Require to set on ODU protocol SDV5.

*** Not in a package, needs to be used adapter from field DC 24V, 1A.



COMMUNICATION WIRING BETWEEN THE INDOOR UNIT AND SDV6 OUTDOOR UNIT

ALL IDU SDV6 SERIES COMMUNICATION M1, M2

M1 M2 communication wiring configuration – IDUs uniform power supplied

$L1+La+Ln \leq 2000m$. Communication wiring $2 \times 0.75mm^2$

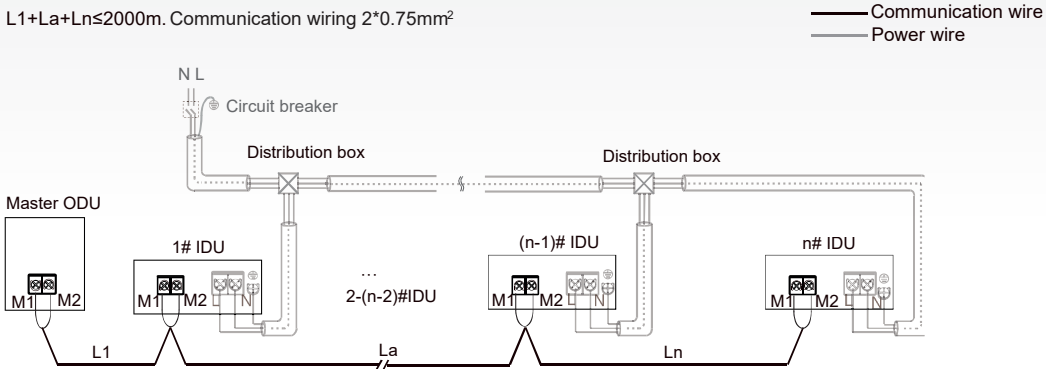

ALL IDU SDV6 SERIES COMMUNICATION M1, M2 WITH SEPARATE POWER SUPPLY

REPEATER SDV6-RPT IS REQUESTED EVERY 10ID'S SDV6. MAX. 2xSDV6-PRT, MAX. 30ID'S.

M1 M2 communication wiring configuration – IDUs separate power supplied

$L1+La+Lx \leq 200m$, $L11+Lb+Ly \leq 200m$, $L21+Lc+L30 \leq 200mm$. Communication wiring $2 \times 1.5mm^2$

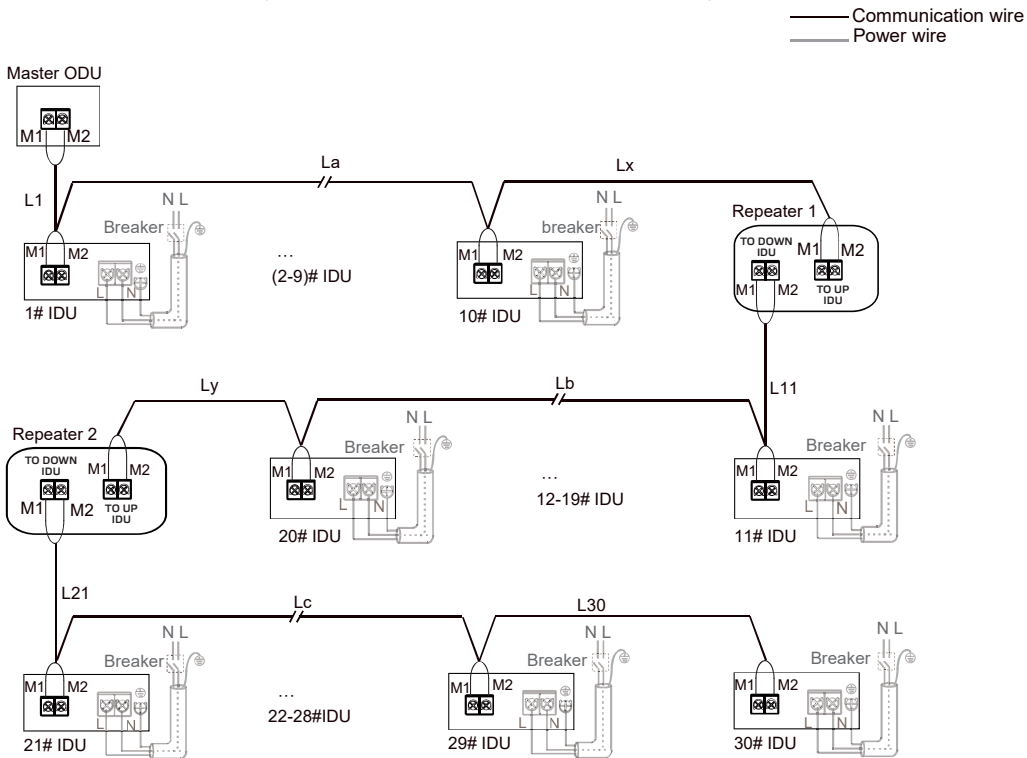

COMMUNICATION WIRING BETWEEN THE INDOOR UNIT AND SDV6 OUTDOOR UNIT

ALL IDU SDV6 SERIES COMMUNICATION P, Q

P Q communication wiring configuration – IDUs uniform power supplied

- RS-485 (P Q) communication wiring configuration
 $L1+La+Ln \leq 1200m$. Communication wiring $2 \times 0.75mm^2$

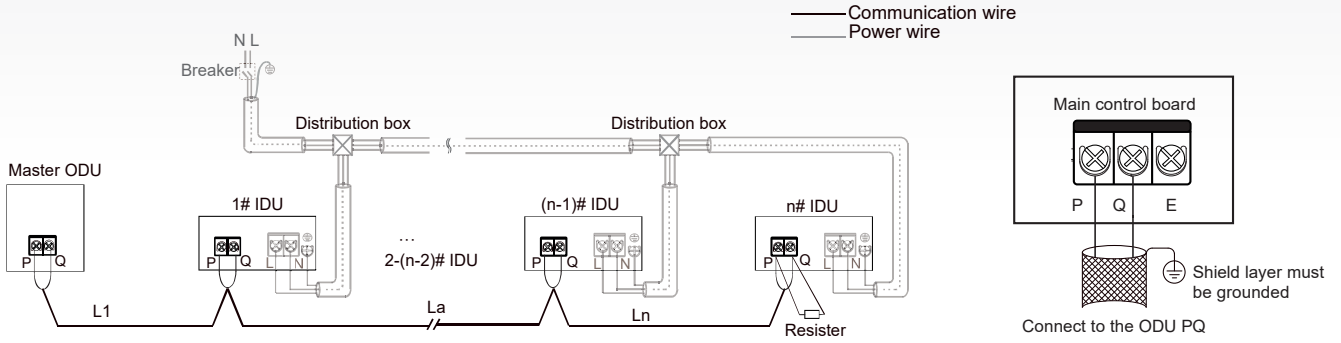

MIX IDU SDV5 AND SDV6 SERIES COMMUNICATION P, Q, E

P Q E communication wiring configuration – IDUs uniform power supplied

- RS-485 (P Q E) communication wiring configuration
 $L1+La+Ln \leq 1200m$. Communication wiring $3 \times 0.75mm^2$

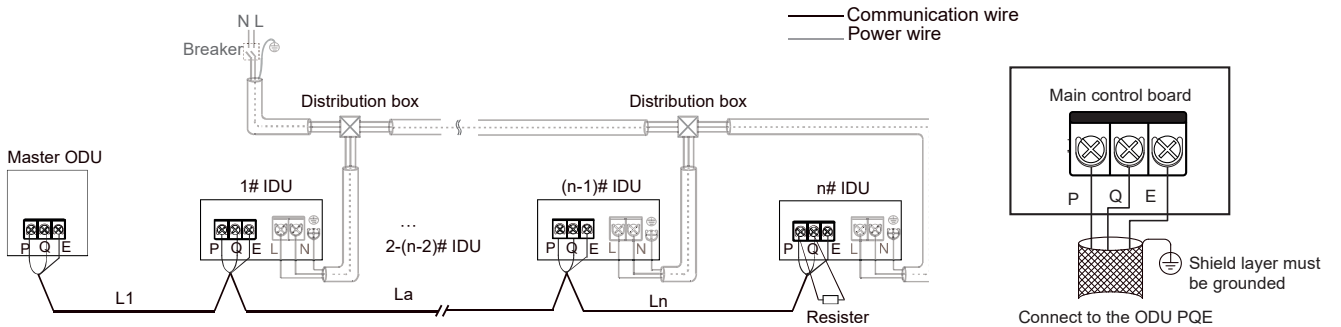

SDV6 INDIVIDUAL SERIES: CENTRAL CONTROLLER, BMS AND DIGITAL ENERGY METER CONNECTION

- X, Y, E, OA communication wiring

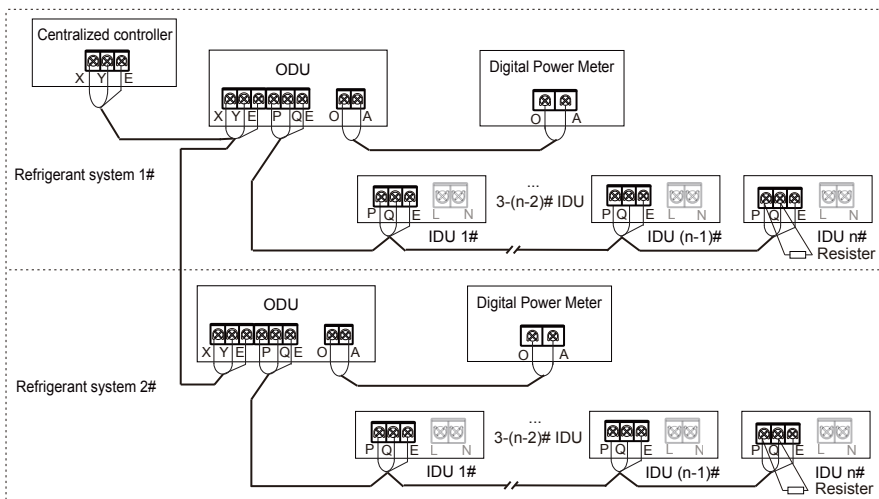

COMMUNICATION WIRING BETWEEN THE INDOOR UNIT AND SDV6 OUTDOOR UNIT

SDV6 MODULAR SERIES: CENTRAL CONTROLLER, BMS AND DIGITAL ENERGY METER CONNECTION

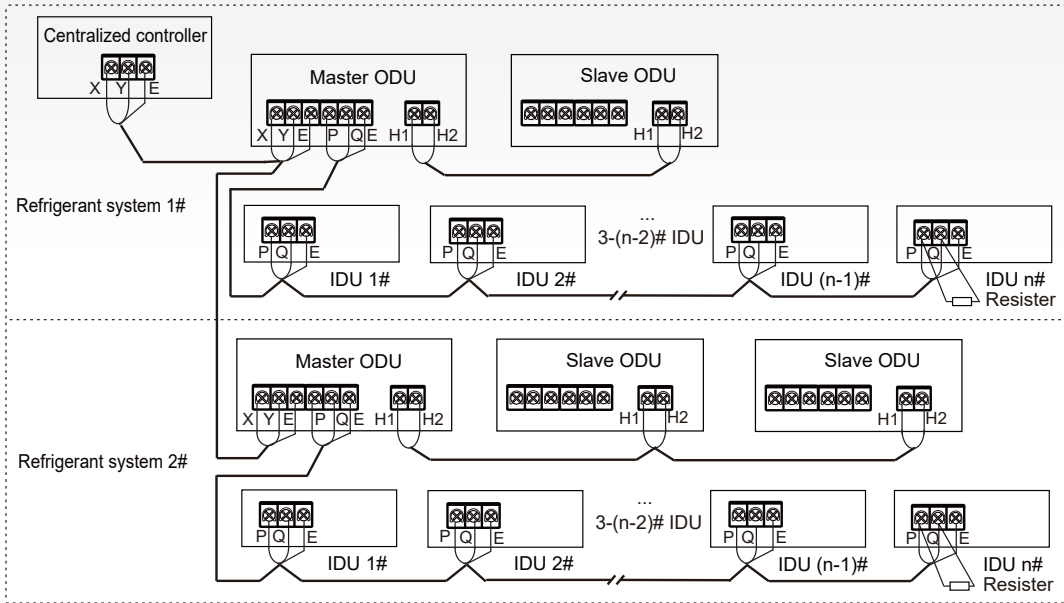

COMMUNICATION WIRING BETWEEN THE INDOOR UNIT AND WIRED CONTROLLER

One-to-one and two-to-one

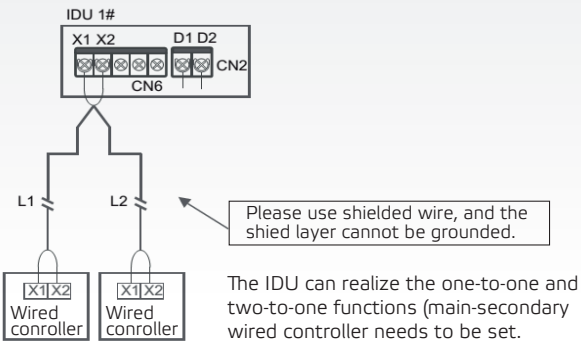

One-to-more and two-to-more

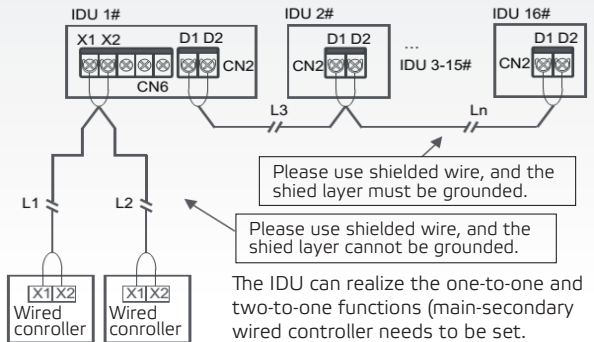

Use 1 wired controller (SWC-86ED or SWC-120G or SWC-61/62/63) to control 1 indoor unit or 2 wired controllers (2xSWC-86ED or 2xSWC-120G or 2xSWC-61/62/63: master and slave controller) to control 1 indoor unit.

Use 1 wired controller (SWC-61/62/63) to control multiple indoor units or 2 wired controllers (2xSWC-61/62/63: master and slave controller) to control multiple indoor units up to 16.

COMPATIBLE WITH ID SDV4, SDV4F, SDV5 AND SDV6

Model	Gas side joints	Liquid side joints
SDV4-HN01k SREF-01 up to 22,4kW		
SDV4-HN02k SREF-02 22,4-32,9kW		
SDV4-HN03k SREF-03 33-103,9kW		
SDV4-HN04k SREF-04 104-153,9kW		
SDV4-HN05k SREF-05 154-234,9kW		
SDV4-HN06k SREF-06 235-302,3kW		
SDV4-HN07k SREF-07 above 302,4kW		

GENERAL OVERVIEW OF ERROR CODES AND OPERATING STATUS CODES

APPLIES TO SDV6 OUTDOOR UNITS	
A01	Emergency stop
AAx	No.x Inverter driver board does not match the main control board
xA61	No.x slave unit error
xb53	No.x Heat dissipation fan error
C13	The address of outdoor Unit is repeated
C21	Communication error between indoor and master outdoor unit
C26	Number of indoor units detected by master unit has decreased or less than the setting amount
C28	Number of indoor units detected by master unit has increased or more than the setting amount
xC31	Communication error between No.x slave outdoor unit and master outdoor unit
C32	Number of slave units detected by master unit has decreased
C33	Number of slave units detected by master unit has increased
xC41	Communication Error between main control board and No.x inverter driver board
E41	Outdoor ambient temperature sensor (T4) error(open/short)
F31	Microchannel heat exchanger outlet temperature sensor(T6B) error(open/short)
F41	Main heat exchanger pipe temperature sensor (T3) error(open/short)
F51	Microchannel heat exchanger inlet temperature sensor(T6A) error(open/short)
F62	Inverter driver board temperature (Tf) protection
F63	Non-inductive resistance temperature(Tr)protection
F6A	F62 protection occurs 3 times in 100 minutes
xF71	Discharge temperature sensor(T7C1/T7C2) error (open/short)
F72	Discharge temperature(T7C1/T7C2) protection
F75	Compressor discharge insufficient superheat protection
F7A	F72 protection occurs 3 times in 100 minutes
F81	Gas pipe temperature sensor (Tg) error (open/short)
F91	Liquid pipe temperature sensor (T5) error (open/short)
FA1	Outdoor Heat exchanger gas temperature sensor (T8) error (open/short)
FC1	Outdoor heat exchanger liquid temperature sensor (TL) error (open/short)
xFd1	Compressor suction temperature sensor (T71/T72) error (open/short)
Fp1	Electric control box chamber temperature sensor (Tb) error (open/short)
xL01	xL1* or xL2* error occurs 3 times in 60 minutes
xL-	No.(x) compressor error, "-" refer in Service manual to Table Compressor drive error code table
xJ01	xJ1* or xJ2* error occurs 10 times in 60 minutes
xJ-	No.(x) fan motor error, "-" refer in Service manual in Table Fan motor error code table
P11	High pressure sensor error
P12	High pressure protection
P13	High pressure switch protection
P14	P12 protection occurs 3 times in 60 minutes
P21	Low pressure sensor error
P22	Low pressure protection
P24	Abnormal rise of low pressure
P25	P22 protection occurs 3 times in 100 minutes
xP32	No.(x) compressor high DC bus current protection
xP33	xP32 protection occurs 3 times in 100 minutes
P51	High AC voltage protection
P52	Low AC voltage protection
P53	Phase B and N of the power cable are connected to the opposite protection
P54	DC bus low voltage protection
P55	DC bus ripple over protection
xP56	No.(x) Inverter driver board DC bus low voltage error
xP57	No.(x) Inverter driver board DC bus high voltage error
xP58	No.(x) Inverter driver board DC bus excessively high voltage error
P71	EEPROM error
Pb1	HyperLink overcurrent error
Pd1	Anti-condensation protection
Pd2	Pd1 protection occurs 2 times in 60 minutes

1b01	Electronic expansion valve (EEVA) error
2b01	Electronic expansion valve (EEVB) error
3b01	Electronic expansion valve (EEVC) error
4b01	Electronic expansion valve (EEVE) error
bA1	HyperLink cannot open or close indoor unit's Electronic expansion valve
ODU SDV6 OPERATING STATUS CODE (NON-ERROR)	
d0x	Oil return,"x" is the current step node
dfx	Defrost, "x" is the current step node
d11	The outdoor ambient temperature exceeds the upper limit (Heating mode)
d12	The outdoor ambient temperature exceeds the lower limit (Heating mode)
d13	The outdoor ambient temperature exceeds the upper limit (Cooling mode)
d14	The outdoor ambient temperature exceeds the lower limit (Cooling mode)
d31	Refrigerant judgment: no result
d32	Refrigerant quantity judgment: Significantly excessive
d33	Refrigerant quantity judgment: Slightly excessive
d34	Refrigerant quantity judgment: normal
d35	Refrigerant quantity judgment: Slightly insufficient
d36	Refrigerant quantity judgment: Significantly insufficient
d41	System exist no power indoor unit, HyperLink is controlling this indoor unit's valve
APPLIES TO SDV6 INDOOR UNITS	
A01	Emergency stop
A11	R32 refrigerant leaks, requiring shutdown immediately
A51	Outdoor unit fault
A71	The fault of the linked FAPU is transmitted to the master indoor unit (series setting)
A72	The fault of the linked humidifying indoor unit is transmitted to the master indoor unit
A73	The fault of the linked FAPU is transmitted to the master indoor unit (non-series setting)
A74	The fault of the AHU Kit slave unit is sent to the master unit
A81	Self-check fault
A82	MS (refrigerant flow direction switching device) fault
A91	Mode conflict
b11	1# EEV coil fault
b12	1# EEV body fault
b13	2# EEV coil fault
b14	2# EEV body fault
b34	Stall protection on 1# water pump
b35	Stall protection on 2# water pump
b36	Water level switch alarm
b71	Reheating electric heater fault
b72	Preprocessing electric heater fault
b81	Humidifier fault
C11	Duplicate indoor unit address code
C21	Abnormal communication between the indoor unit and outdoor unit
C41	Abnormal communication between the indoor unit main control board and fan drive board
C51	Abnormal communication between the indoor unit and wired controller
C52	Abnormal communication between the indoor unit and Wi-Fi Kit
C61	Abnormal communication between the indoor unit main control board and display board
C71	Abnormal communication between the AHU Kit slave unit and master unit
C72	Number of AHU Kits is not the same as the set number
C73	Abnormal communication between the linked humidifying indoor unit and master indoor unit
C74	Abnormal communication between the linked FAPU and master indoor unit (series setting)
C75	Abnormal communication between the linked FAPU and master indoor unit (non-series setting)
C76	Abnormal communication between the main wired controller and secondary wired controller
C77	Abnormal communication between the indoor unit main control board and 1# Expansion board
C78	Abnormal communication between the indoor unit main control board and 2# Expansion board
C79	Abnormal communication between the indoor unit main control board and Switch board
d16	Air inlet temperature of the indoor unit is too low in heating mode

GENERAL OVERVIEW OF ERROR CODES AND OPERATING STATUS CODES

d17	Air inlet temperature of the indoor unit is too high in cooling mode
d81	Alarm for exceeding temperature and humidity range
dE1	Sensor control board fault
dE2	PM2.5 sensor fault
dE3	CO2 sensor fault
dE4	Formaldehyde sensor fault
dE5	Human Detect sensor fault
E21	T0 (fresh inlet air temperature sensor) short-circuits or cuts off
E22	The upper dry bulb temperature sensor short-circuits or cuts off
E23	The lower dry bulb temperature sensor short-circuits or cuts off
E24	T1 (Indoor unit return air temperature sensor) short-circuits or cuts off
E31	The built-in room temperature sensor of the wired controller short-circuits or cuts off
E32	The wireless temperature sensor short-circuits or cuts off
E33	The external room temperature sensor short-circuits or cuts off
E61	Tcp (pre-cooled fresh air temperature sensor) short-circuits or cuts off
E62	Tph (pre-heated fresh air temperature sensor) short-circuits or cuts off
E81	TA (outlet air temperature sensor) short-circuits or cuts off
EA1	Outlet air humidity sensor fault
EA2	Return air humidity sensor fault
EA3	Upper wet bulb sensor fault
EA4	Lower wet bulb sensor fault
EC1	R32 refrigerant leakage sensor fault
F01	T2A (heat exchanger inlet temperature sensor) short-circuits or cuts off
F11	T2 (heat exchanger middle temperature sensor) short-circuits or cuts off
F12	T2 (heat exchanger middle temperature sensor) overtemperature protection
F21	T2B (heat exchanger outlet temperature sensor) short-circuits or cuts off
P71	Main control board EEPROM fault
P72	Indoor unit display control board EEPROM fault
U01	Locked (electronic lock)
U11	Unit model code not set
U12	Capacity(HP) code not set
U14	Capacity(HP) code setting error
U15	AHU Kit fan control input signal DIP setting error
U38	Address code not detected
J01	Motor failed more than once
J1E	IPM (fan module) overcurrent protection
J11	Instantaneous overcurrent protection for phase current
J3E	Low bus voltage fault
J31	High bus voltage fault
J43	Phase current sample bias error
J45	Motor and indoor unit are unmatched
J47	IPM and indoor unit are unmatched
J5E	Motor startup failure
J52	Motor blocking protection
J55	Speed control mode setting error
J6E	Phase lack protection of motor
IDU SDV6 OPERATING STATUS CODE (NON-ERROR)	
d0	Oil return or preheating operation
dC	Self-cleaning
dd	Mode conflict
dF	Defrosting
d51	Static pressure detection
d61	Remote shutdown
d71	Indoor unit backup operation
d72	outdoor unit backup operation
OTA	Main control program upgrading

OUTDOOR UNITS

MINI CHILLERS

MODEL			SCV-50EB	SCV-70EB	SCV-100EB	SCV-120EB	SCV-140EB
Power supply		V/Ph/Hz	220-240/1/50				
Heating A7W35	Capacity	W	6500	8400	10000	12200	14100
	Rated input	W	1226	1663	2128	2490	3000
	EER	-	5,30	5,05	4,70	4,90	4,70
Heating A2W35	Capacity	W	5600	7100	8200	12300	13000
	Rated input	W	1333	1797	2158	3417	3714
	EER	-	4,20	3,95	3,80	3,60	3,50
Cooling A35W7	Capacity	W	5500	7400	9000	11600	13400
	Rated input	W	1692	2349	3103	3742	4573
	COP	-	3,25	3,15	2,90	3,10	2,93
Cooling A35W18	Capacity	W	6500	8300	10000	12200	13900
	Rated input	W	1275	1711	2326	2652	3159
	COP	-	5,1	4,85	4,3	4,6	4,4
Seasonal space heating energy efficiency class	Water outlet at 35°C	-	A+++	A+++	A+++	A+++	A+++
SCOP average climate	Water outlet at 35°C	-	5,12	5,18	5,12	5,08	4,89
	Water outlet at 55°C	-	3,59	3,67	3,71	3,62	3,62
SEER	Water outlet at 7°C	-	5,12	5,18	5,12	5,08	4,89
	Water outlet at 18°C	-	7,81	8,09	8,31	7,79	7,59
Sound power level2	Heating max.	dB(A)	64	66	68	74	74
	Cooling max.	dB(A)	64	66	68	74	74
Sound pressure level		dB(A)	48	51	53	56	58
Compressor	Type		DC twin rotary	DC twin rotary	DC twin rotary	DC twin rotary	DC twin rotary
Fan	Motor type		DC Motor	DC Motor	DC Motor	DC Motor	DC Motor
	Air flow	m³/h	3900	5100	7000	7000	7000
Air heat exchanger	Type		Fin-coil				
Water heat exchanger	Type		Plate heat exchanger				
Rated water flow		m³/h	1,12	1,44	1,77	2,10	2,43
Water flow range		m³/h	0,40-1,25	0,40-1,65	0,40-2,10	0,70-2,50	0,70-2,50
Water pump	Type	-	DC	DC	DC	DC	DC
	Max. pump head	m	9	9	9	9	9
Expansion tank volume	Volume	L	5	5	5	5	5
Safety valve		MPa	0,3	0,3	0,3	0,3	0,3
Flow switch		m³/h	0,36	0,36	0,36	0,6	0,6
Throttle	Type		Electronic expansion valve				
Refrigerant	Type		R32	R32	R32	R32	R32
	Charged volume	kg / t eq. CO ₂	1,25 / 0,84	1,25 / 0,84	1,25 / 0,84	1,8 / 1,22	1,8 / 1,22
Unit net dimension (WxHxD)		mm	1040x865x410	1040x865x410	1040x865x410	1040x865x410	1040x865x410
Packing dimension (WxHxD)		mm	1190x970x560	1190x970x560	1190x970x560	1190x970x560	1190x970x560
Net / Gross weight		kg	87/103	87/103	87/103	106/122	106/122
Pipe connections	Water inlet/outlet	-	G1"BSP	G1"BSP	G1"BSP	G5/4"BSP	G5/4"BSP
Controller			Wire controller SWC-120F (standard)				
Ambient temperature range	Cooling	°C	-5-43	-5-43	-5-43	-5-43	-5-43
	Heating	°C	-25-35	-25-35	-25-35	-25-35	-25-35
Water outlet temperature range	Cooling	°C	5-25	5-25	5-25	5-25	5-25
	Heating	°C	25-65	25-65	25-65	25-65	25-65
ADDITIONAL TECHNICAL INFORMATION							
Screw holes distance of chiller	w x d	mm	656x458	656x458	656x458	656x458	656x458
Recommended power cable		mm²	3x4,0	3x4,0	3x4,0	3x6,0	3x6,0
Recommended air switch		A	B20	B20	B20	B32	B32
EQUIPMENT							
Crancase heater			yes	yes	yes	yes	yes
Drain pipe connector			yes	yes	yes	yes	yes
ON/OFF connector			yes (dry-contact)	yes (dry-contact)	yes (dry-contact)	yes (dry-contact)	yes (dry-contact)
External room thermostat			yes	yes	yes	yes	yes
Alarm or Defrost connector			yes	yes	yes	yes	yes
Additional pump connector			yes	yes	yes	yes	yes
STANDARD ACCESSORIES							
Wire controller			yes (modbus)	yes (modbus)	yes (modbus)	yes (modbus)	yes (modbus)
Hydraulic module			yes	yes	yes	yes	yes

1. The above data test reference standard EN14511; EN14825; EN50564; EN12102; (EU) No:811/2013; (EU)No:813/2013; OJ 2014/C 207/02.

2. Sound pressure level is measured at a position 1m in front of the unit and (1+H)/2 m (where H is the height of the unit) above the floor in a semi-anechoic chamber. During in-site operation, sound pressure levels may be higher as a result of ambient noise.

The specification of products is subject to change based on further development of the units by the producer and can be changed without prior notice. Refer to rating label.

Contains fluorinated greenhouse gases covered by the Kyoto Protocol. R32 (50% HFC-32, 50% HFC-125), GWP of refrigerant used: 675.

OUTDOOR UNITS

MINI CHILLERS

MODEL			SCV-160EB	SCV-120EB-3	SCV-140EB-3	SCV-160EB-3	
Power supply		V/Ph/Hz	220-240/1/50		380-415/3/50		
Heating A7W35	Capacity	W	16000	12200	14100	16000	
	Rated input	W	3556	2490	3000	3556	
	EER	-	4,50	4,90	4,70	4,50	
Heating A2W35	Capacity	W	14500	12300	13000	14500	
	Rated input	W	4462	3417	3714	4462	
	EER	-	3,25	3,60	3,50	3,25	
Cooling A35W7	Capacity	W	14000	11600	13400	14000	
	Rated input	W	4828	3742	4573	4828	
	COP	-	2,90	3,10	2,93	2,90	
Cooling A35W18	Capacity	W	15400	12200	13900	15400	
	Rated input	W	3667	2652	3159	3667	
	COP	-	4,2	4,6	4,4	4,2	
Seasonal space heating energy efficiency class	Water outlet at 35°C	-	A+++	A+++	A+++	A+++	
SCOP average climate	Water outlet at 35°C	-	4,84	5,08	4,89	4,84	
	Water outlet at 55°C	-	3,59	3,62	3,62	3,59	
SEER	Water outlet at 7°C	-	4,84	5,08	4,89	4,84	
	Water outlet at 18°C	-	7,49	7,86	7,65	7,54	
Sound power level2	Heating max.	dB(A)	74	74	74	74	
	Cooling max.	dB(A)	74	74	74	74	
Sound pressure level		dB(A)	58	57	59	59	
Compressor	Type		DC twin rotary	DC twin rotary	DC twin rotary	DC twin rotary	
Fan	Motor type		DC Motor	DC Motor	DC Motor	DC Motor	
	Air flow	m³/h	7000	7000	7000	7000	
Air heat exchanger	Type		Fin-coil				
Water heat exchanger	Type		Plate heat exchanger				
Rated water flow		m³/h	2,75	2,10	2,43	2,75	
Water flow range		m³/h	0,70-3,00	0,70-2,50	0,70-2,50	0,70-3,00	
Water pump	Type	-	DC	DC	DC	DC	
	Max. pump head	m	9	9	9	9	
Expansion tank volume	Volume	L	5	5	5	5	
Safety valve		MPa	0,3	0,3	0,3	0,3	
Flow switch		m³/h	0,6	0,6	0,6	0,6	
Throttle	Type		Electronic expansion valve				
Refrigerant	Type		R32	R32	R32	R32	
	Charged volume	kg / t eq. CO ₂	1,8 / 1,22	1,8 / 1,22	1,8 / 1,22	1,8 / 1,22	
Unit net dimension (WxHxD)		mm	1040x865x410	1040x865x410	1040x865x410	1040x865x410	
Packing dimension (WxHxD)		mm	1190x970x560	1190x970x560	1190x970x560	1190x970x560	
Net / Gross weight		kg	106/122	120/136	120/136	120/136	
Pipe connections	Water inlet/outlet	-	G5/4"BSP	G5/4"BSP	G5/4"BSP	G5/4"BSP	
Controller			Electronic controller (standard)				
Ambient temperature range	Cooling	°C	-5-43	-5-43	-5-43	-5-43	
	Heating	°C	-25-35	-25-35	-25-35	-25-35	
Water outlet temperature range	Cooling	°C	5-25	5-25	5-25	5-25	
	Heating	°C	25-65	25-65	25-65	25-65	
ADDITIONAL TECHNICAL INFORMATION							
Screw holes distance of chiller	w x d	mm	656x458	656x458	656x458	656x458	
Recommended power cable		mm²	3x6,0	5x2,5	5x2,5	5x2,5	
Recommended air switch		A	B32	B16	B16	B16	
EQUIPMENT							
Cranecase heater			yes	yes	yes	yes	
Drain pipe connector			yes	yes	yes	yes	
ON/OFF connector			yes (dry-contact)	yes (dry-contact)	yes (dry-contact)	yes (dry-contact)	
External room thermostat			yes	yes	yes	yes	
Alarm or Defrost connector			yes	yes	yes	yes	
Additional pump connector			yes	yes	yes	yes	
STANDARD ACCESSORIES							
Wire controller			yes (modbus)	yes (modbus)	yes (modbus)	yes (modbus)	
Hydraulic module			yes	yes	yes	yes	

1. The above data test reference standard EN14511; EN14825; EN50564; EN12102; (EU) No:811/2013; (EU)No:813/2013; OJ 2014/C 207/02.

2. Sound pressure level is measured at a position 1m in front of the unit and (1+H)/2 m (where H is the height of the unit) above the floor in a semi-anechoic chamber. During in-site operation, sound pressure levels may be higher as a result of ambient noise.

The specification of products is subject to change based on further development of the units by the producer and can be changed without prior notice. Refer to rating label.

Contains fluorinated greenhouse gases covered by the Kyoto Protocol. R32 (50% HFC-32, 50% HFC-125), GWP of refrigerant used: 675.

APPEARANCE AND DIMENSIONS OF OUTDOOR UNIT

MINI CHILLERS

SCV-50/70/100/120/140/160EB/EB-3

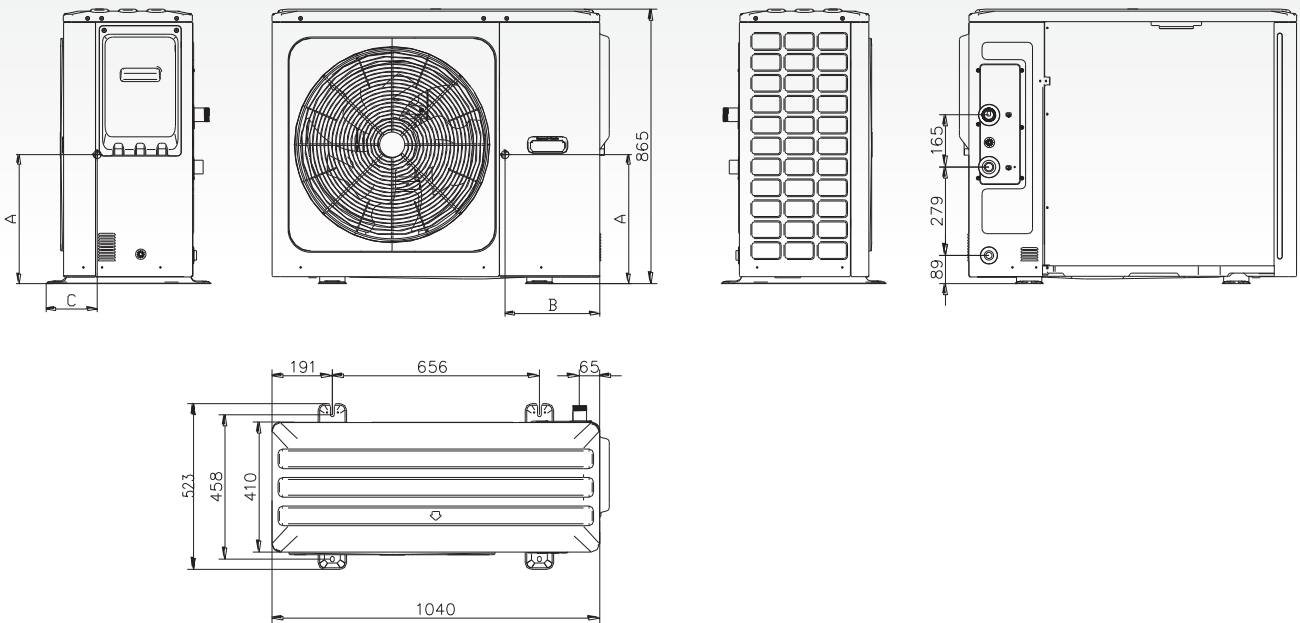

Model	A (mm)	B (mm)	C (mm)
SCV-50EB SCV-70EB SCV-100EB	350	355	285
SCV-120EB SCV-140EB SCV-160EB	540	390	255
SCV-120EB-3 SCV-140EB-3 SCV-160EB-3	500	400	275

Unit	5kW	7kW	10kW	12kW	14kW	16kW	12kW 3-PH	14kW 3-PH	16kW 3-PH
Maximum overcurrent protector(MOP)(A)	18	18	18	30	30	30	14	14	14
Wiring size(mm ²)	4.0	4.0	4.0	6.0	6.0	6.0	2.5	2.5	2.5

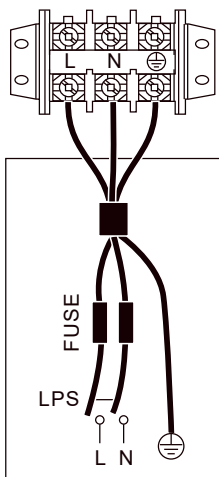

UNIT POWER SUPPLY
1-phase

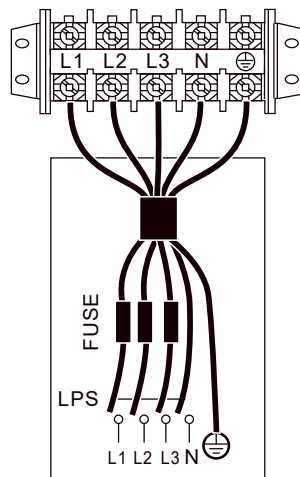

UNIT POWER SUPPLY
3-phase

MINI CHILLERS

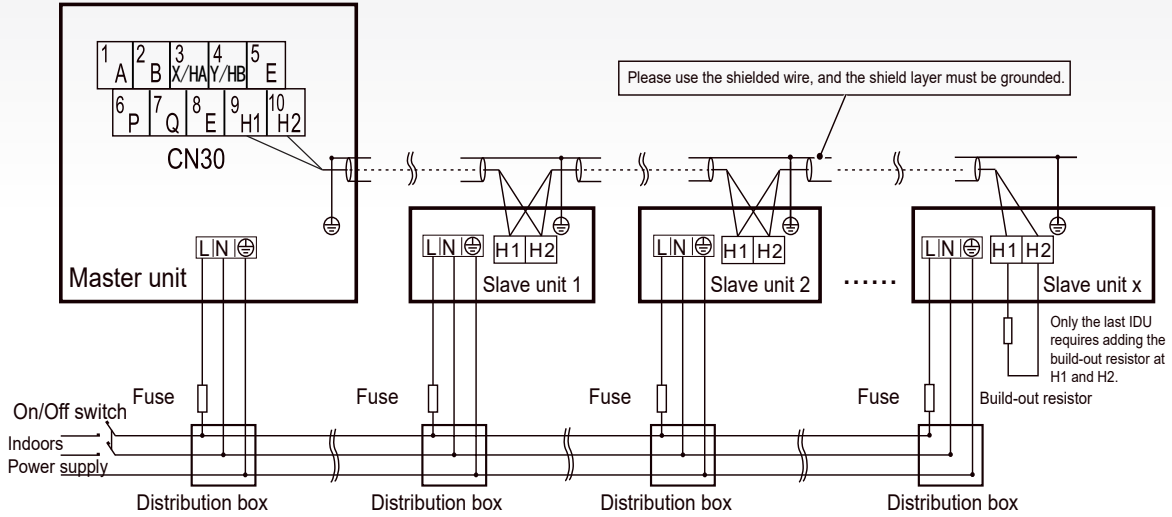
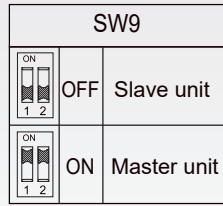

The cascade system electrical control system connection diagram(1N~)

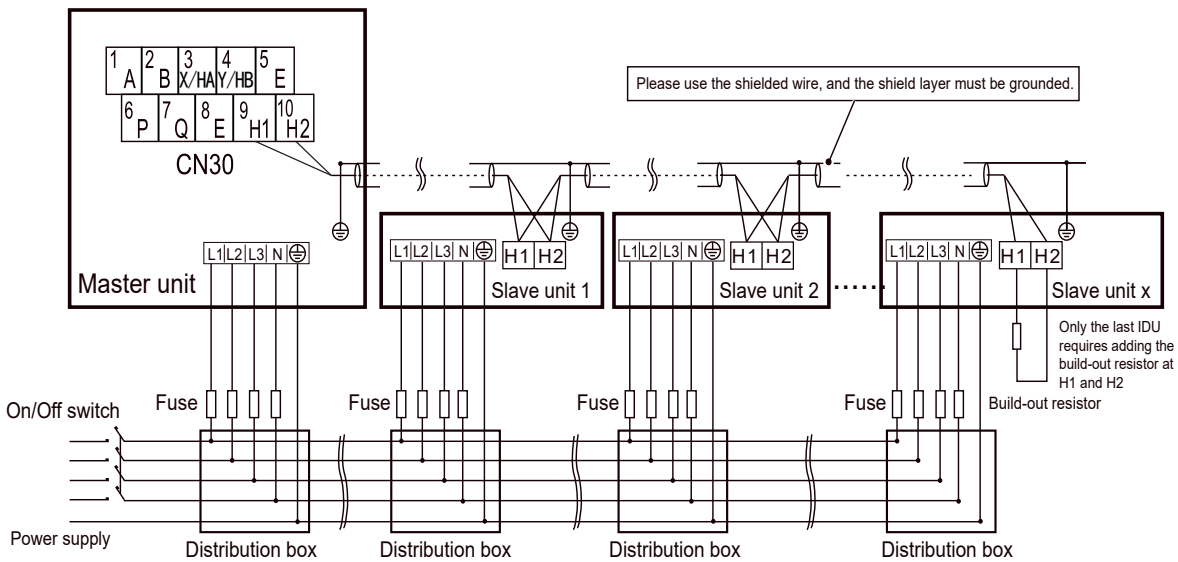
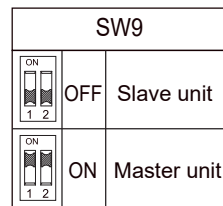

The cascade system electrical control system connection diagram(3N~)

OUTDOOR UNITS

MODULAR CHILLERS

MODEL			SCV-750EB	SCV-750EBH	SCV-900EB	SCV-900EBH		
Power supply		V/Ph/Hz	380-415/3/50					
Cooling1	Capacity	kW	70	69,7	82	82		
	Input	kW	26,8	27,3	27,8	28,3		
	EER	-	2,61	2,55	2,95	2,90		
	SEER	-	4,30	4,22	4,50	4,44		
Heating2	Capacity	kW	75	75,4	90	90		
	Input	kW	23,7	24,3	28,1	29		
	COP	-	3,16	3,10	3,2	3,10		
	SCOP	-	4,05	3,95	3,97	3,77		
Max. running current		A	46	49	60	63		
Compressor	Type		DC inverter rotary	DC inverter rotary	DC inverter rotary	DC inverter rotary		
	Quantity	Pieces	1	1	2	2		
Air side heat exchanger	Type		Finned tube	Finned tube	Finned tube	Finned tube		
	Quantity of fan motor	Pieces	2	2	2	2		
	Air flow	m³/h	28500	28500	35000	35000		
Water side heat exchanger	Type		Plate	Plate	Plate	Plate		
	Water pressure drop	kPa	65	-	75	-		
	Volume	L	5,17	5,17	7,05	7,05		
	Water flow volume	m³/h	12,04	12,04	15	15		
Refrigerant	Type		R32	R32	R32	R32		
	Charged volume	kg / t eq. CO ₂	9 / 6,075	9 / 6,075	16 * (11,5+4,5) / 10,8	16 * (11,5+4,5) / 10,8		
	Throttle type		EXV	EXV	EXV	EXV		
Sound pressure level3		dB(A)	69	69	65	65		
Unit net dimension (DxHxW)		mm	960x1770x2000	960x1770x2000	1135x2315x2220	1135x2315x2220		
Packing dimension (DxHxW)		mm	1030x1890x2085	1030x1890x2085	1180x2445x2250	1180x2445x2250		
Net / Gross weight		kg	440/455	475/490	635/660	686/711		
Pipe connections	Water inlet/outlet	mm	DN50	DN50	DN50	DN50		
Water pipe connection type			Hoop connection	Hoop connection	Hoop connection	Hoop connection		
Controller			Wired controller KJRM-120H2 (standard)					
Ambient temperature range	Cooling	°C	-10~48					
	Heating	°C	-20~43	-20~43	-20~43	-20~43		
Water outlet temperature range	Cooling	°C	5~20					
	Heating	°C	25~54	25~54	25~54	25~54		
ADDITIONAL TECHNICAL INFORMATION								
Screw holes distance of chiller	w x d	mm	1550x862	1550x862	1460x1017	1460x1017		
Recommended power cable		mm²	5x16	5x16	5x25	5x25		
Recommended air switch		A	B63	B63	B100	B100		
EQUIPMENT								
Crankcase heater			yes	yes	yes	yes		
Drain pipe connector			-	-	-	-		
ON/OFF connector			yes (dry-contact)	yes (dry-contact)	yes (dry-contact)	yes (dry-contact)		
Cool/Heat connector			yes (dry-contact)	yes (dry-contact)	yes (dry-contact)	yes (dry-contact)		
Alarm connector			yes (230V)	yes (230V)	yes (230V)	yes (230V)		
STANDARD ACCESSORIES								
Wire controller			yes (support ModBus)	yes (support ModBus)	yes (support ModBus)	yes (support ModBus)		
Hydraulic module			no	yes	no	yes		

Nominal capacity is based on the following conditions:

1. Cooling: Chilled water inlet/outlet temperature: 12/7 °C, outdoor ambient temperature 35 °C DB.
2. Heating: Warm water inlet/outlet temperature: 40/45 °C, outdoor ambient temperature 7 °C DB/6 °C WB.
3. Sound pressure level is measured at a position 1m in front of the unit and 1.1m above the floor in a semi-anechoic chamber.

Water side fouling factor: 0.086 m² °C / kW.

* The total amount of refrigerant is 16 kg, including the 11,5 kg already charged before delivery and the 4,5 kg to be charged.

** The total amount of refrigerant is 15,5 kg, including the 11,5 kg already charged before delivery and the 4 kg to be charged.

*** The total amount of refrigerant is 32 kg, including the 2x 5,5 kg already charged before delivery and the 2x 10,5 kg to be charged.

The specification of products is subject to change based on further development of the units by the producer and can be changed without prior notice. Refer to rating label.

Contains fluorinated greenhouse gases covered by the Kyoto Protocol. R32 (100% HFC-32), GWP of refrigerant: 675. Noise is tested in the semi-anechoic room, so it should be slightly higher due to change of location. Power input is tested under standard conditions.

OUTDOOR UNITS

MODULAR CHILLERS

MODEL			SCV-1400EB	SCV-1400EBH	SCV-1800EB	SCV-1800EBH	
Power supply		V/Ph/Hz			380-415/3/50		
Cooling1	Capacity	kW	130	129,5	164	163	
	Input	kW	50,5	51,4	56	57,7	
	EER	-	2,57	2,52	2,93	2,82	
	SEER	-	4,40	4,32	4,41	4,35	
Heating2	Capacity	kW	138	138,6	180	181,2	
	Input	kW	44,5	45,6	57	59,1	
	COP	-	3,10	3,04	3,16	3,07	
	SCOP	-	3,90	3,73	3,80	3,65	
Max. running current		A	90	94	120	94	
Compressor	Type		DC inverter rotary	DC inverter rotary	DC inverter rotary	DC inverter rotary	
	Quantity	Pieces	2	2	4	4	
Air side heat exchanger	Type		Finned tube	Finned tube	Finned tube	Finned tube	
	Quantity of fan motor	Pieces	2	2	4	4	
	Air flow	m³/h	50000	50000	70000	70000	
Water side heat exchanger	Type		Plate	Plate	Plate	Plate	
	Water pressure drop	kPa	65	-	96	-	
	Volume	L	11,1	11,1	6,96x2	6,96x2	
	Water flow volume	m³/h	22,36	22,36	28,2	28,2	
Refrigerant	Type		R32	R32	R32	R32	
	Charged volume	kg / t eq. CO ₂	15,5** (11,5+4) / 10,463	15,5** (11,5+4) / 10,463	16*** (5,5+10,5)*2 / 21,6	16*** (5,5+10,5)*2 / 21,6	
	Throttle type		EXV	EXV	EXV	EXV	
Sound pressure level3		dB(A)	73	74	72	72	
Unit net dimension (DxHxW)		mm	1135x2300x2220	1135x2300x2220	2220x2413x2752	2220x2413x2752	
Packing dimension (DxHxW)		mm	1180x2425x2250	1180x2425x2250	2245x2446x2810	2245x2446x2810	
Net / Gross weight		kg	670/690	746/767	1400/1420	1500/1504	
Pipe connections	Water inlet/outlet	mm	DN65	DN65	DN80	DN80	
Water pipe connection type			Hoop connection	Hoop connection	Hoop connection	Hoop connection	
Controller			Wired controller KJRM-120H2 (standard)				
Ambient temperature range	Cooling	°C	-10-48	-10-48	-10-48	-10-48	
	Heating	°C	-20-43	-20-43	-20-43	-20-43	
Water outlet temperature range	Cooling	°C	5-20	5-20	5-20	5-20	
	Heating	°C	25-54	25-54	25-54	25-54	
ADDITIONAL TECHNICAL INFORMATION							
Screw holes distance of chiller	w x d	mm	1460x1017	1460x1017	2120x2752	2120x2752	
Recommended power cable		mm²	5x50	5x50	5x70	5x70	
Recommended air switch		A	B160	B160	B200	B200	
EQUIPMENT							
Cranecase heater			yes	yes	yes	yes	
Drain pipe connector			-	-	-	-	
ON/OFF connector			yes (dry-contact)	yes (dry-contact)	yes (dry-contact)	yes (dry-contact)	
Cool/Heat connector			yes (dry-contact)	yes (dry-contact)	yes (dry-contact)	yes (dry-contact)	
Alarm connector			yes (230V)	yes (230V)	yes (230V)	yes (230V)	
STANDARD ACCESSORIES							
Wire controller			yes (support ModBus)	yes (support ModBus)	yes (support ModBus)	yes (support ModBus)	
Hydraulic module			no	yes	no	yes	

Nominal capacity is based on the following conditions:

1. Cooling: Chilled water inlet/outlet temperature: 12/7 °C, outdoor ambient temperature 35 °C DB.
2. Heating: Warm water inlet/outlet temperature: 40/45 °C, outdoor ambient temperature 7 °C DB/6 °C WB.
3. Sound pressure level is measured at a position 1m in front of the unit and 1.1m above the floor in a semi-anechoic chamber.

Water side fouling factor: 0.086 m² °C / kW.

* The total amount of refrigerant is 16 kg, including the 11,5 kg already charged before delivery and the 4,5 kg to be charged.

** The total amount of refrigerant is 15,5 kg, including the 11,5 kg already charged before delivery and the 4 kg to be charged.

*** The total amount of refrigerant is 32 kg, including the 2x 5,5 kg already charged before delivery and the 2x 10,5 kg to be charged.

The specification of products is subject to change based on further development of the units by the producer and can be changed without prior notice. Refer to rating label.

Contains fluorinated greenhouse gases covered by the Kyoto Protocol. R32 (100% HFC-32), GWP of refrigerant: 675. Noise is tested in the semi-anechoic room, so it should be slightly higher due to change of location. Power input is tested under standard conditions.

APPEARANCE AND DIMENSIONS OF OUTDOOR UNIT

MODULAR CHILLERS

SCV-750EB/750EBH

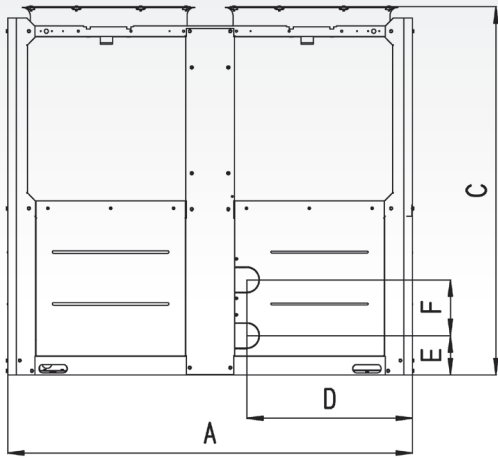

Front view

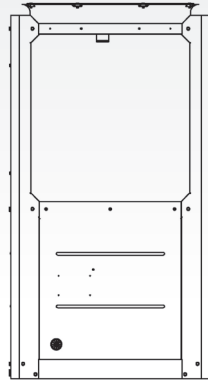

Left view

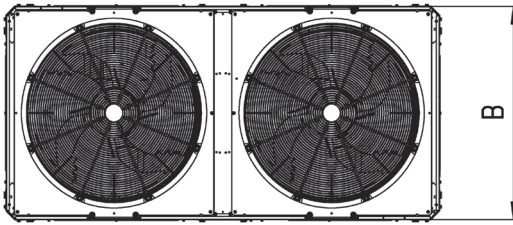

Top view

SCV-1800EB/EBH

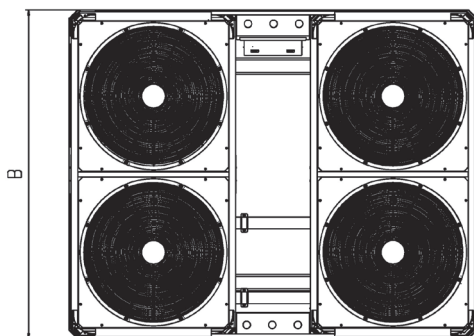
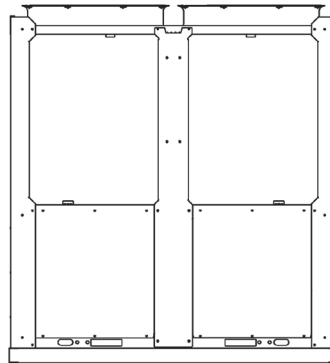
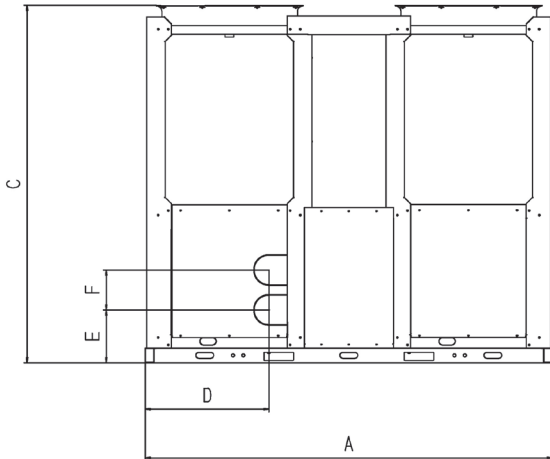

Top view

APPEARANCE AND DIMENSIONS OF OUTDOOR UNIT

MODULAR CHILLERS

SCV-900EB/900EBH, SCV-1400EB/EBH

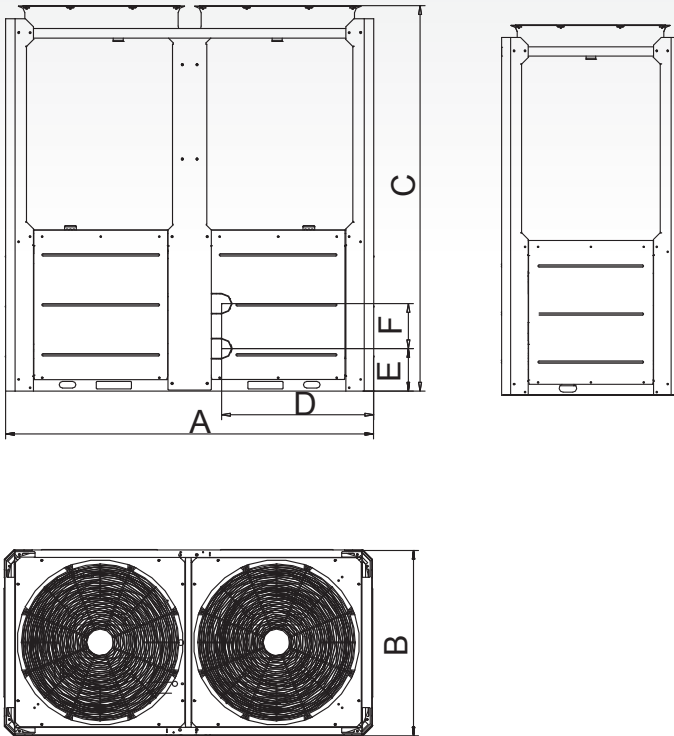

Model	SCV-750EB/EBH	SCV-900EB/EBH	SCV-1400EB/EBH	SCV-1800EB/EBH
A (mm)	2000	2220	2220	2752
B (mm)	960	1135	1135	2220
C (mm)	1770	2315	2300	2413
D (mm)	816	910	910	836
E (mm)	190	255	185	356
F (mm)	270	270	380	270
G (mm)	-	-	-	-
H (mm)	-	-	-	-
I (mm)	-	-	-	-

COOLING OPERATING RANGE

MODULAR CHILLERS

SCV-750EB, SCV-900EB, SCV-1400EB, SCV-1800EB

SCV-750EBH, SCV900EBH, SCV-1400EBH, SCV-1800EBH

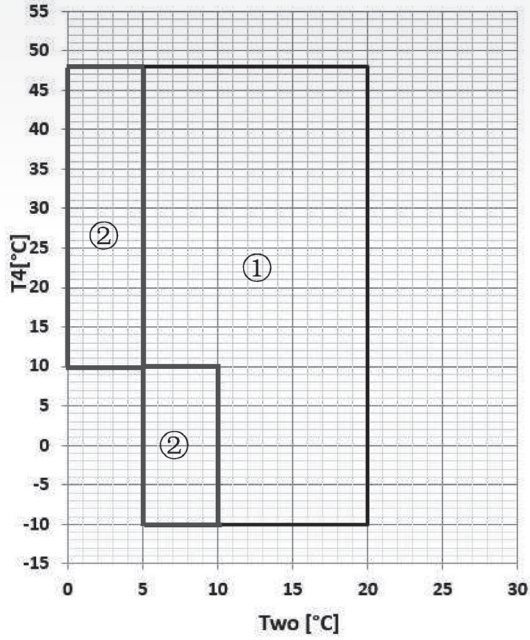

- ① Normal mode
- ② Low leaving water temperature mode

More information in documentation

HEATING OPERATING RANGE

SCV-750EB, SCV-750EBH

SCV-1400EB, SCV-1400EBH

SCV-900EB, SCV900EBH

SCV-1800EB, SCV-1800EBH

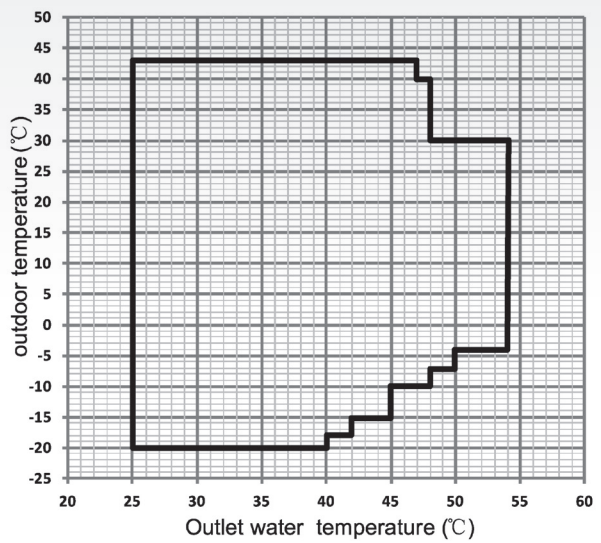
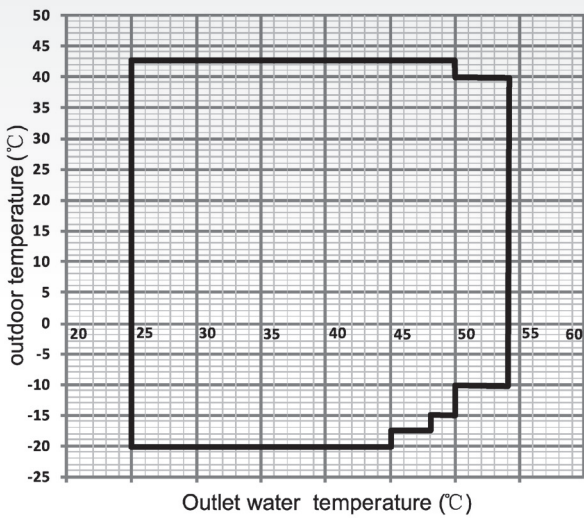

EXPANSION BOLT POSITIONING

MODULAR CHILLERS

SCV-750EB/750EBH

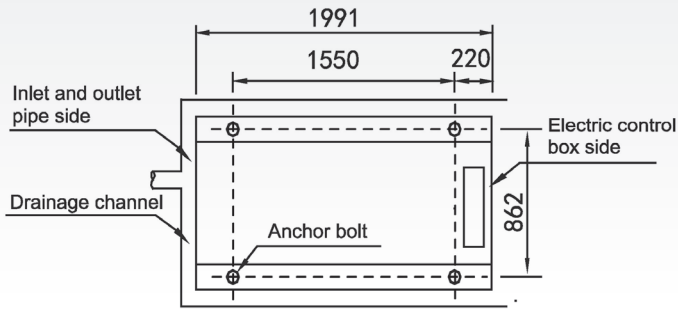
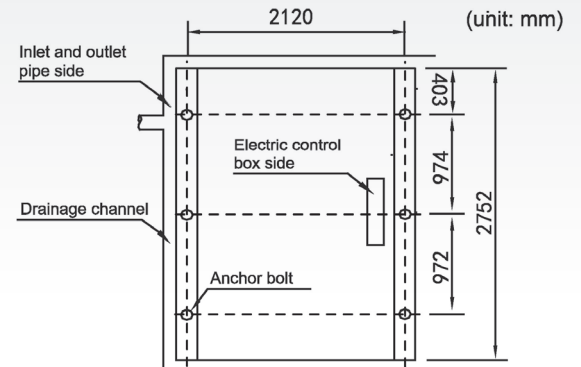
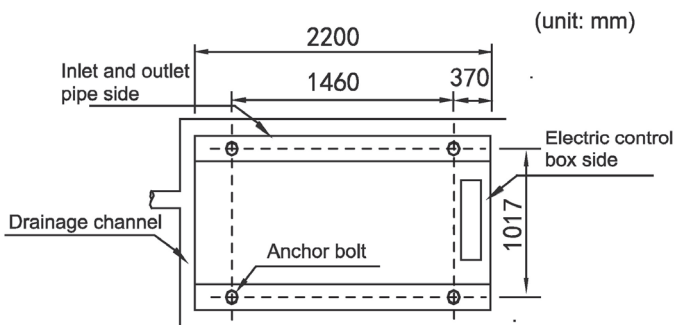

Fig. 6-6 Top view of schematic diagram of installation dimension of SCV-750EB

SCV-1800EB/1800EBH



SCV-900EB/900EBH, SCV-1400EB/1400EBH



DETAIL OF PIPE CONNECTIONS

SCV-750EB/750EBH

SCV-900EB/900EBH

SCV-1400EB/1400EBH

SCV-1800EB/1800EBH

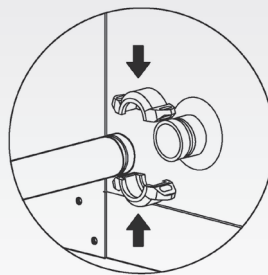

Model	Pipe connection methods	Spec. of water pipe	Spec. of screw thread
SCV-750EB/EBH	Hoop	DN50	-
SCV-900EB/EBH	Hoop	DN50	-
SCV-1400EB/EBH	Hoop	DN65	-
SCV-1800EB/EBH	Hoop	DN80	-

Hoop connection needs to be purchased locally type Victaulic QuickVic Style 177N. SINCLAIR doesn't offer this.

INDOOR UNITS

FCU COMPACT FOUR-WAY CASSETTE, 2 PIPES

MODEL			SF-300C2M	SF-400C2M	SF-500C2M
Power supply		V/Ph/Hz	220-240/1/50		
Air flow (H/M/L)		m³/h	535/429/322	610/477/381	781/611/494
		CFM	314/252/189	359/281/224	459/359/290
Cooling	Capacity (H/M/L)	kW	2,98/2,53/2	3,96/3,26/2,76	4,2/3,48/3,01
	Water flow rate	m³/h	0,53/0,45/0,35	0,7/0,58/0,51	0,75/0,61/0,54
	Water pressure drop	kPa	10/7/5	11,48/8,2/6,54	12,32/8,62/7,4
Heating	Capacity (H/M/L)	kW	4,01/3,35/2,61	5,4/4,34/3,57	5,76/4,69/3,84
	Water pressure drop	kPa	8,2/6/3,8	12,68/6,4/4,92	11,41/6,5/5,41
Max. power input		W	15	28	43
Sound pressure level (H/M/L)		dB(A)	39/33/27	42/36/30	43/38/32
Sound power level (H/M/L)		dB(A)	51/45/39	54/48/42	55/50/44
Fan motor	Type		DC motor	DC motor	DC motor
	Quantity		1	1	1
Fan	Type		Centrifugal, forward-curved blades		
	Quantity		1	1	1
Coil	Row		2	2	2
	Max. working pressure	MPa	1,6	1,6	1,6
	Diameter	mm	Φ7	Φ7	Φ7
Panel	Net dimensions (WxHxD)	mm	647x50x647	647x50x647	647x50x647
	Packing size (WxHxD)	mm	715x123x715	715x123x715	715x123x715
	Net weight	kg	2,5	2,5	2,5
	Gross weight	kg	4,5	4,5	4,5
Body	Net dimensions (WxHxD)	mm	575x261x575	575x261x575	575x261x575
	Packing size (WxHxD)	mm	670x290x670	670x290x670	670x290x670
	Net weight	kg	16,5	16,5	16,5
	Gross weight	kg	22,5	22,5	22,5
Pipe connections	Water inlet/outlet pipe	inch	G3/4	G3/4	G3/4
	Drain pipe	mm	Φ25	Φ25	Φ25

ADDITIONAL TECHNICAL INFORMATION						
Recommended power cable	Below 20 m	mm²	3x2,5	3x2,5	3x2,5	
Recommended air switch		A	B16	B16	B16	

EQUIPMENT						
Drain pump			yes	yes	yes	
Max. lift (from bottom of ID)		mm	600	600	600	
Built-in 3-way valve			no	no	no	
Control 2 or 3-way valve			yes (230V)	yes (230V)	yes (230V)	
Alarm connector			yes (230V)	yes (230V)	yes (230V)	
ON/OFF connector			yes (dry-contact)	yes (dry-contact)	yes (dry-contact)	
Fresh air inlet		mm	Φ75	Φ75	Φ75	
BMS modbus RTU			yes	yes	yes	

STANDARD ACCESSORIES						
Water outlet joint			yes	yes	yes	
Clasp			yes	yes	yes	
Remote controller (IR)			R05	R05	R05	

OPTIONAL ACCESSORIES						
Wire controller			KJR-29B	KJR-29B	KJR-29B	
Central controller			SCM-30	SCM-30	SCM-30	

Note: H: High fan speed; M: Medium fan speed; L: Low fan speed. Cooling mode: entering air temperature 27 °C DB/19 °C WB, entering/leaving water temperature 7 °C /12 °C. Heating mode: entering air temperature 20 °C DB, enter water teperature 50 °C. Same water flow as in standard rating condition in cooling. The specification of products is subject to change based on further development of the units by the producer and can be changed without prior notice. Refer to rating label.

APPEARANCE AND DIMENSIONS OF INDOOR UNITS

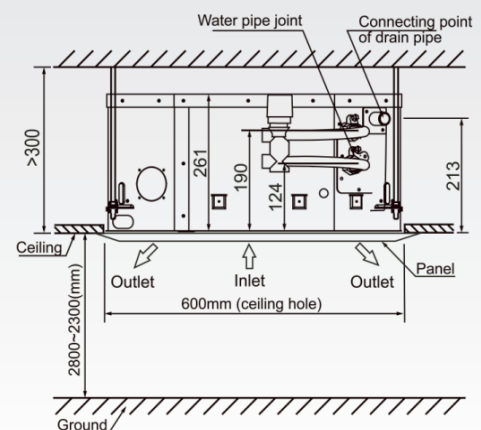
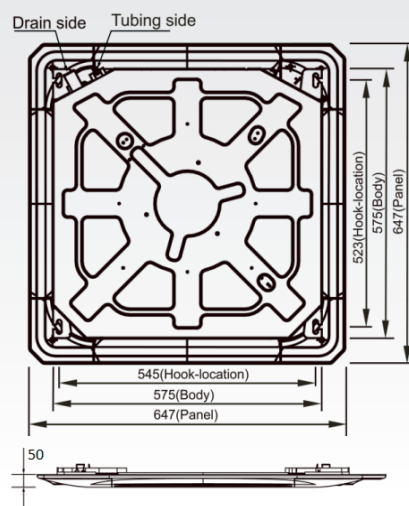

INDOOR UNITS

FCU SF2 FOUR-WAY CASSETTE, 2 PIPES

MODEL			SF2-600C2	SF2-700C2	SF2-800C2	SF2-1000C2	SF2-1200C2
Power supply		V/Ph/Hz	220-240/1/50				
Air flow (SH/MH/H/M/L/ML/SL)		m³/h	1020/950/880/780/ 700/620/490	1190/1090/990/900/ 790/680/560	1360/1280/1180/1040/ 920/800/650	1700/1600/1450/1250/ 1150/1000/810	1950/1850/1650/1450/ 1300/1150/950
		CFM	600/558/517/458/ 411/364/288	700/641/582/529/ 464/400/329	800/752/694/611/ 541/470/382	1000/941/852/735/ 676/588/476	1147/1088/970/852/ 764/676/558
Cooling	Capacity (SH/MH/H/M/L/ML/SL)	kW	5,50/5,25/5,00/4,55/4,00/ 3,20/2,70	6,50/6,10/5,70/5,10/4,80/ 4,40/3,75	7,50/7,00/6,50/6,00/5,50/ 4,90/4,30	8,50/8,20/7,65/6,95/6,40/ 5,80/4,85	10,50/10,00/9,50/8,90/ 8,00/7,10/6,20
	Water flow rate	m³/h	1,04/0,97/0,90/0,81/0,71/ 0,58/0,49	1,20/1,08/0,99/0,90/0,82/ 0,76/0,70	1,33/1,23/1,13/1,06/0,96/ 0,85/0,77	1,56/1,46/1,35/1,22/1,12/ 1,01/0,86	2,02/1,89/1,76/1,64/1,50/ 1,32/1,16
Heating	Capacity (SH/MH/H/M/L/ML/SL)	kW	6,50/6,20/5,90/5,25/4,85/ 4,30/3,55	7,50/7,20/6,60/6,10/5,50/ 5,00/4,10	8,50/7,90/7,20/6,60/5,90/ 5,40/4,70	9,50/9,35/8,75/8,10/7,40/ 6,60/5,80	12,00/11,20/10,50/9,95/ 9,00/8,00/6,90
	Water flow rate	m³/h	1,18/1,09/1,04/0,94/0,84/ 0,75/0,64	1,35/1,28/1,19/1,07/0,97/ 0,88/0,81	1,48/1,39/1,28/1,17/1,03/ 0,93/0,83	1,73/1,66/1,57/1,44/1,30/ 1,16/1,02	2,23/2,08/1,89/1,72/1,56/ 1,38/1,20
Water pressure drop		kPa	45/35/32/30/25/20/18	30/28/25/20/18/16/14	35/32/29/25/20/18/14	45/40/35/30/25/20/18	45/40/35/30/25/20/17
Max. power input		W	40	45	60	100	200
Sound pressure level (SH/MH/H/M/L/ML/SL)		dB(A)	39,8/37,5/35,2/32,3/29,2/ 25,9/22,3	37,4/34,6/31,8/28,9/25,9/ 23,5/20,7	41,4/38,7/35,8/32,5/29,1/ 25,9/23,1	46,8/44,5/41,6/38,4/34,8/ 30,8/26,8	51,5/49,3/46,9/44,2/40,7/ 36,7/32,0
Sound power level (SH/MH/H/M/L/ML/SL)		dB(A)	51,5/49,1/46,5/43,6/40,4/ 36,9/33,6	50,9/48,4/45,6/42,8/39,9/ 39,1/36,7	52,7/50,2/47,5/44,5/41,2/ 37,4/35,3	59,1/56,8/54,1/51,1/47,7/ 43,9/40,3	63,5/61,2/58,6/55,7/52,4/ 48,5/44,1
Fan motor	Type		DC motor	DC motor	DC motor	DC motor	DC motor
	Quantity		1	1	1	1	1
Fan	Type		Centrifugal, forward-curved blades				
	Quantity		1	1	1	1	1
Coil	Row		2	2	2	2	3
	Max. working pressure	MPa	1,6	1,6	1,6	1,6	1,6
	Diameter	mm	Φ7	Φ7	Φ7	Φ7	Φ7
Panel	Net dimensions (WxHxD)	mm	950x77x950	950x77x950	950x77x950	950x77x950	950x77x950
	Packing size (WxHxD)	mm	1020x90x1020	1020x90x1020	1020x90x1020	1020x90x1020	1020x90x1020
	Net weight	kg	5,8	5,8	5,8	5,8	5,8
	Gross weight	kg	7,6	7,6	7,6	7,6	7,6
Body	Net dimensions (WxHxD)	mm	840x204x840	840x288x840	840x288x840	840x288x840	840x288x840
	Packing size (WxHxD)	mm	940x250x940	940x335x940	940x335x940	940x335x940	940x335x940
	Net weight	kg	19,3	23,6	23,6	23,6	25,9
	Gross weight	kg	22,3	26,2	26,2	26,2	28,3
Pipe connections	Water inlet/outlet pipe	inch	RC3/4	RC3/4	RC3/4	RC3/4	RC3/4
	Drain pipe	mm	Φ25	Φ25	Φ25	Φ25	Φ25
ADDITIONAL TECHNICAL INFORMATION							
Recommended power cable	Below 20m	mm²	3x2,5	3x2,5	3x2,5	3x2,5	3x2,5
Recommended air switch		A	B16	B16	B16	B16	B16
EQUIPMENT							
Drain pump			yes	yes	yes	yes	yes
Max. lift (from bottom of ID)		mm	1200	1200	1200	1200	1200
Built-in 3-way valve			no	no	no	no	no
Control 2 or 3-way valve			yes (230V)	yes (230V)	yes (230V)	yes (230V)	yes (230V)
Alarm connector			yes (230V)	yes (230V)	yes (230V)	yes (230V)	yes (230V)
ON/OFF connector			yes (dry-contact)	yes (dry-contact)	yes (dry-contact)	yes (dry-contact)	yes (dry-contact)
Fresh air inlet		mm	Φ103	Φ103	Φ103	Φ103	Φ103
BMS modbus RTU			yes	yes	yes	yes	yes
OPTIONAL ACCESSORIES							
Remote controller (IR)			SRC-61	SRC-61	SRC-61	SRC-61	SRC-61
Wire controller			SWC-61, SWC-62, SWC-63	SWC-61, SWC-62, SWC-63	SWC-61, SWC-62, SWC-63	SWC-61, SWC-62, SWC-63	SWC-61, SWC-62, SWC-63
Central controller			SCM-30	SCM-30	SCM-30	SCM-30	SCM-30
Control fan speed (H/M/L), ON/OFF, Alarm			SF2-CTK	SF2-CTK	SF2-CTK	SF2-CTK	SF2-CTK
Control fan speed (0-10V), valve control 0-10V			SF2-EC*	SF2-EC*	SF2-EC*	SF2-EC*	SF2-EC*

*SF2-EC require SF2-CTK

Cooling mode: entering air temperature 27°C DB/19°C WB, entering/leaving water temperature 7°C /12°C.

Heating mode: entering air temperature 20°C DB, entering/leaving water temperature 45/40°C.

Sound power levels are measured 1m around the unit in a semi-anechoic chamber. During in-situ operation. Sound pressure levels are measured 1m below and right of the unit in a semi-anechoic chamber.

The specification of products is subject to change based on further development of the units by the producer and can be changed without prior notice. Refer to rating label.

APPEARANCE AND DIMENSIONS OF FAN COIL UNIT

FCU SF2 FOUR-WAY CASSETTE, 2 PIPES

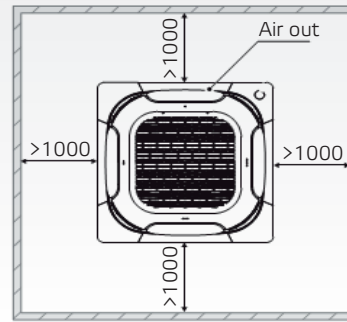
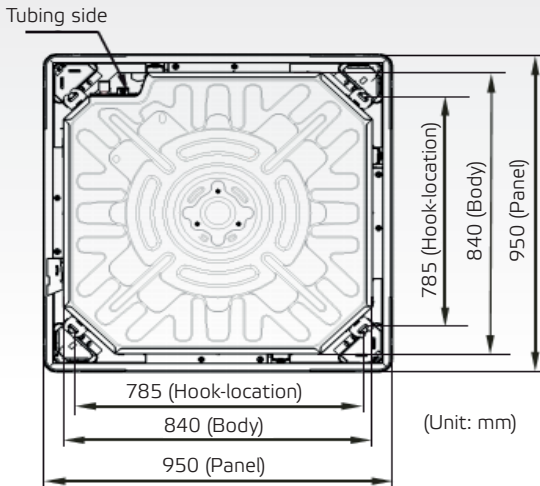

Model	Size (mm)					
	A	B	C	D	E	F
SF2-600C2	140	103	323	85	155	204
SF2-700-1200C2	140	103	323	160	230	288
SF2-600-1200C4	140	103	323	160	230	288

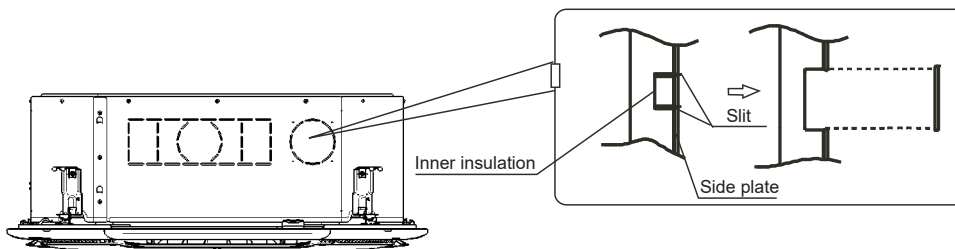
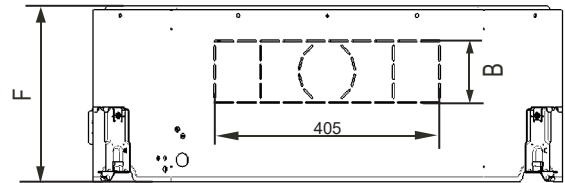
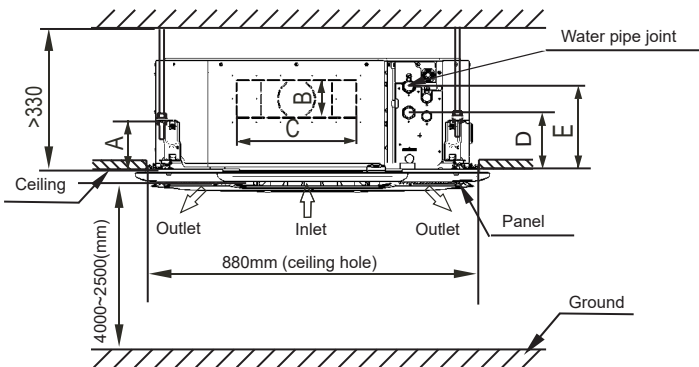

FCU COMPACT FOUR-WAY CASSETTE, 4 PIPES

MODEL			SF-300C4M	SF-400C4M	SF-500C4M		
Power supply		V/Ph/Hz		220-240/1/50			
Air flow (H/M/L)		m³/h	493/395/295	669/523/415	673/526/425		
		CFM	290/232/173	393/307/244	395/309/250		
Cooling	Capacity (H/M/L)	kW	2,16/1,86/1,49	2,78/2,38/2,05	2,77/2,38/2,07		
	Water flow rate	m³/h	0,42/0,37/0,3	0,53/0,46/0,4	0,56/0,49/0,43		
	Water pressure drop	kPa	17,4/13,5/9,3	13,15/9,4/7	16,8/13,1/10,3		
Heating	Capacity (H/M/L)	kW	3,56/2,99/2,36	4,25/3,58/3,02	4,51/3,79/3,22		
	Water flow rate	m³/h	0,36/0,31/0,25	0,41/0,36/0,31	0,47/0,4/0,36		
	Water pressure drop	kPa	29,8/21,7/14,3	30,4/22,2/16,7	36,1/25,9/19		
Max. power input		W	24	38	42		
Sound pressure level (H/M/L)		dB(A)	39/33/27	42/35/30	44/39/31		
Sound power level (H/M/L)		dB(A)	51/45/39	54/47/42	56/51/43		
Fan motor	Type		DC motor	DC motor	DC motor		
	Quantity		1	1	1		
Fan	Type		Centrifugal, forward-curved blades				
	Quantity		1	1	1		
Coil	Row		2	2	2		
	Max. working pressure	MPa	1,6	1,6	1,6		
	Diameter	mm	φ7	φ7	φ7		
Panel	Net dimensions (WxHxD)	mm	647x50x647	647x50x647	647x50x647		
	Packing size (WxHxD)	mm	715x123x715	715x123x715	715x123x715		
	Net weight	kg	2,5	2,5	2,5		
	Gross weight	kg	4,5	4,5	4,5		
Body	Net dimensions (WxHxD)	mm	575x261x575	575x261x575	575x261x575		
	Packing size (WxHxD)	mm	675x320x675	675x320x675	675x320x675		
	Net weight	kg	16,7	16,7	16,7		
	Gross weight	kg	22,7	22,7	22,7		
Pipe connections	Water inlet/outlet pipe	inch	Cold water: G3/4; Hot water: G1/2				
	Drain pipe	mm	φ25	φ25	φ25		
ADDITIONAL TECHNICAL INFORMATION							
Recommended power cable	Below 20 m	mm²	3x2,5	3x2,5	3x2,5		
Recommended air switch		A	B16	B16	B16		
EQUIPMENT							
Drain pump			yes	yes	yes		
Max. lift (from bottom of ID)		mm	600	600	600		
Built-in 3-way valve			no	no	no		
Control 2 or 3-way valve			yes (230V)	yes (230V)	yes (230V)		
Alarm connector			yes (230V)	yes (230V)	yes (230V)		
ON/OFF connector			yes (dry-contact)	yes (dry-contact)	yes (dry-contact)		
Fresh air inlet		mm	φ75	φ75	φ75		
BMS modbus RTU			yes	yes	yes		
STANDARD ACCESSORIES							
Water outlet joint			yes	yes	yes		
Clasp			yes	yes	yes		
Copper nut			yes	yes	yes		
Remote controller (IR)			R05	R05	R05		
OPTIONAL ACCESSORIES							
Wire controller			KJR-29B	KJR-29B	KJR-29B		
Central controller			SCM-30	SCM-30	SCM-30		

Note: H: High fan speed; M: Medium fan speed; L: Low fan speed. Cooling mode: entering air temperature 27 °C DB/19 °C WB, entering/leaving water temperature 7 °C /12 °C. Heating mode: entering air temperature 20 °C DB, enter water teperature 50 °C. The specification of products is subject to change based on further development of the units by the producer and can be changed without prior notice. Refer to rating label.

APPEARANCE AND DIMENSIONS OF INDOOR UNITS

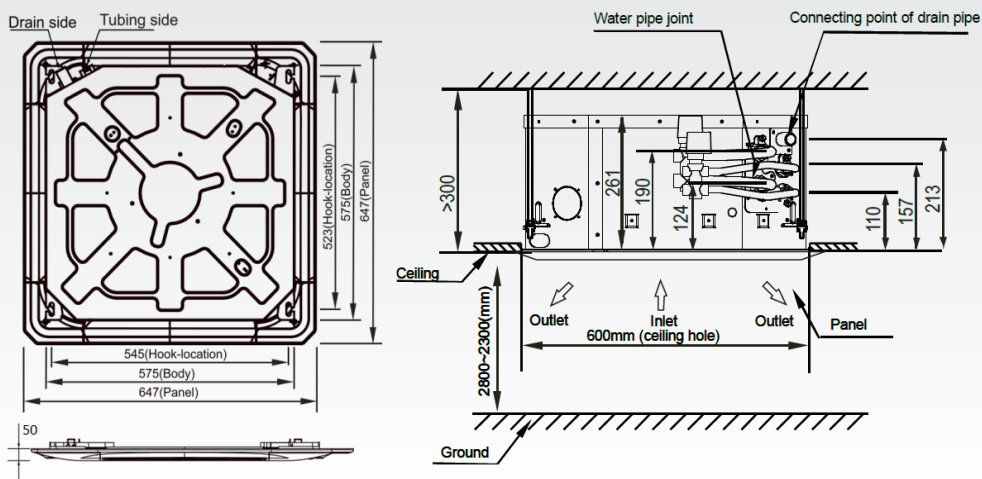

INDOOR UNITS

FCU SF2 FOUR-WAY CASSETTE, 4 PIPES

MODEL			SF2-600C4	SF2-700C4	SF2-800C4
Power supply		V/Ph/Hz	220-240/1/50		
Air flow (SH/MH/H/ML/MLS)		m³/h	1020/930/870/800/ 720/620/520	1190/1080/950/880/ 790/680/560	1360/1250/1120/1000/ 900/800/660
		CFM	600/547/511/470/ 423/364/305	700/635/558/517/ 464/400/329	800/735/658/588/ 529/470/388
Cooling	Capacity (SH/MH/H/ML/MLS)	kW	4,70/4,40/4,00/3,70/3,40/ 3,00/2,65	5,00/4,70/4,40/4,15/3,90/ 3,55/3,00	5,50/5,20/4,90/4,60/4,20/ 3,80/3,40
	Water flow rate	m³/h	0,88/0,82/0,74/0,65/0,60/ 0,53/0,46	0,90/0,88/0,83/0,77/0,74/ 0,67/0,63	1,02/0,98/0,92/0,86/0,76/ 0,69/0,62
Heating	Capacity (SH/MH/H/ML/MLS)	kW	7,30/6,90/6,40/6,00/5,30/ 4,40/3,80	7,00/7,00/6,70/6,40/6,30/ 5,50/4,65	7,50/7,10/6,70/6,35/5,95/ 5,50/5,20
	Water flow rate	m³/h	0,68/0,63/0,59/0,55/0,50/ 0,41/0,33	0,71/0,68/0,64/0,61/0,57/ 0,51/0,41	0,79/0,74/0,69/0,63/0,59/ 0,53/0,46
Water pressure drop		kPa	30/28/26/25/22/16/14	35/32/30/27/25/20/15	40/35/30/28/22/18/17
Max. power input		W	40	45	60
Sound pressure level (SH/MH/H/ML/MLS)		dB(A)	34,2/31,5/29,0/26,3/24,1/ 21,8/20,6	37,4/34,5/31,6/28,4/25,6/ 23,2/21,0	41,2/38,6/35,7/32,2/28,9/ 25,6/22,8
Sound power level (SH/MH/H/ML/MLS)		dB(A)	46,8/44,1/41,4/38,4/35,4/ 32,4/30,3	49,7/47,1/44,2/41,2/37,9/ 35,0/31,8	53,5/50,9/48,0/44,9/41,6/ 38,0/35,1
Fan motor	Type		DC motor	DC motor	DC motor
	Quantity		1	1	1
Fan	Type		Centrifugal, forward-curved blades		
	Quantity		1	1	1
Coil	Row		2	2	2
	Max. working pressure	MPa	1,6	1,6	1,6
	Diameter	mm	Φ7	Φ7	Φ7
Panel	Net dimensions (WxHxD)	mm	950x77x950	950x77x950	950x77x950
	Packing size (WxHxD)	mm	1020x90x1020	1020x90x1020	1020x90x1020
	Net weight	kg	5,8	5,8	5,8
	Gross weight	kg	7,6	7,6	7,6
Body	Net dimensions (WxHxD)	mm	840x288x840	840x288x840	840x288x840
	Packing size (WxHxD)	mm	940x335x940	940x335x940	940x335x940
	Net weight	kg	23,9	23,9	23,9
	Gross weight	kg	26,4	26,4	26,4
Pipe connections	Water inlet/outlet pipe	inch	RC3/4	RC3/4	RC3/4
	Drain pipe	mm	Φ25	Φ25	Φ25
ADDITIONAL TECHNICAL INFORMATION					
Recommended power cable	Below 20m	mm²	3x2,5	3x2,5	3x2,5
Recommended air switch		A	B16	B16	B16
EQUIPMENT					
Drain pump			yes	yes	yes
Max. lift (from bottom of ID)		mm	1200	1200	1200
Built-in 3-way valve			no	no	no
Control 2 or 3-way valve			yes (230V)	yes (230V)	yes (230V)
Alarm connector			yes (230V)	yes (230V)	yes (230V)
ON/OFF connector			yes (dry-contact)	yes (dry-contact)	yes (dry-contact)
Fresh air inlet		mm	Φ103	Φ103	Φ103
BMS modbus RTU			yes	yes	yes
OPTIONAL ACCESSORIES					
Remote controller (IR)			SRC-61	SRC-61	SRC-61
Wire controller			SWC-61, SWC-62, SWC-63	SWC-61, SWC-62, SWC-63	SWC-61, SWC-62, SWC-63
Central controller			SCM-30	SCM-30	SCM-30
Control fan speed (H/M/L), ON/OFF, Alarm			SF2-CTK	SF2-CTK	SF2-CTK
Control fan speed (0-10V), valve control 0-10V			SF2-EC*	SF2-EC*	SF2-EC*

*SF2-EC require SF2-CTK

Cooling mode: entering air temperature 27°C DB/19°C WB, entering/leaving water temperature 7°C /12°C.

Heating mode: entering air temperature 20°C DB, entering/leaving water temperature 65/55°C.

Sound power levels are measured 1m around the unit in a semi-anechoic chamber. During in-site operation. Sound pressure levels are measured 1m below and right of the unit in a semi-anechoic chamber.

The specification of products is subject to change based on further development of the units by the producer and can be changed without prior notice. Refer to rating label.

APPEARANCE AND DIMENSIONS OF FAN COIL UNIT

FCU SF2 FOUR-WAY CASSETTE, 4 PIPES

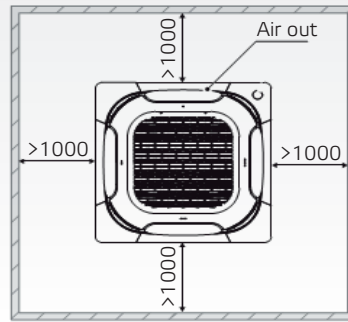
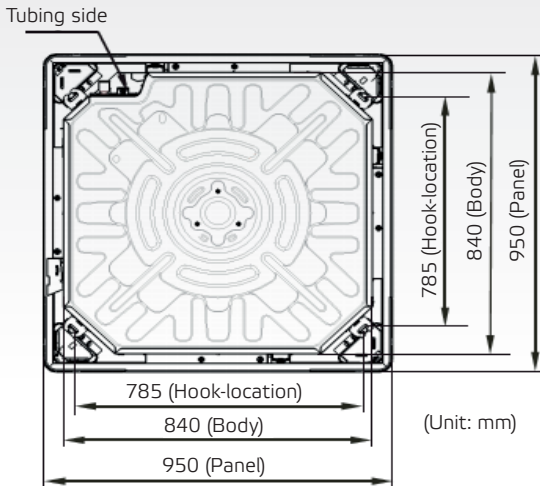

Model	Size (mm)	A	B	C	D	E	F
SF2-600C2		140	103	323	85	155	204
SF2-700-1200C2		140	103	323	160	230	288
SF2-600-1200C4							

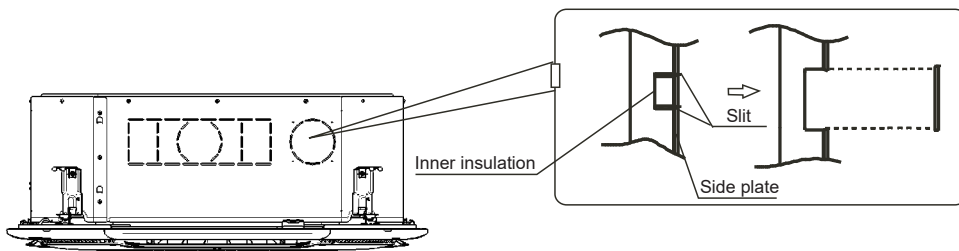
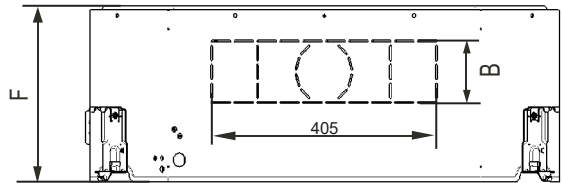
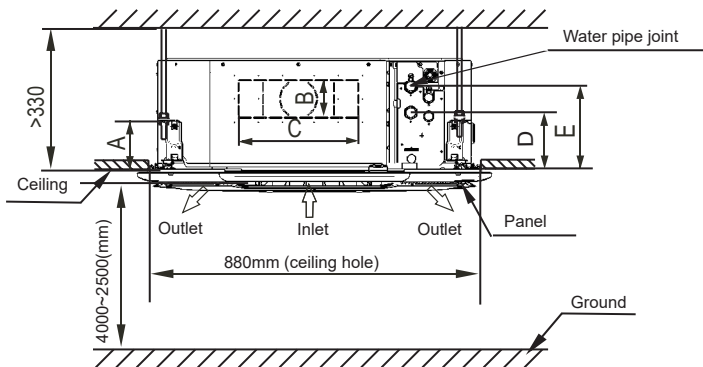

INDOOR UNITS

FCU WALL-MOUNTED

MODEL			SF-250HM2	SF-400HM2	SF-600HM2		
Power supply		V/Ph/Hz	220-240/1/50				
Air flow (H/M/L)		m³/h	492/454/400	825/689/590	979/849/717		
		CFM	289/267/235	485/405/347	575/499/421		
Cooling	Capacity (H/M/L)	kW	2,7/2,59/2,39	3,81/3,3/2,88	4,87/4,26/3,79		
	Water flow rate	m³/h	0,48/0,46/0,42	0,67/0,57/0,51	0,85/0,72/0,65		
	Water pressure drop	kPa	31,6/28,6/25,4	56,8/41,2/33	50,7/39,5/33,7		
Heating	Capacity (H/M/L)	kW	3,29/3,03/2,63	5,08/4,33/3,77	6,31/5,57/4,77		
	Water pressure drop	kPa	37,5/30,3/26,5	61,9/37,9/30,3	51,7/36,3/30,3		
Max. power input		W	13	34	38		
Sound pressure level (H/M/L)		dB(A)	32/30/27	45/39/35	44/40/35		
Fan motor	Type		DC Motor	DC Motor	DC Motor		
	Quantity		1	1	1		
Fan	Type		Tangential fan				
	Quantity		1	1	1		
Coil	Row		2	2	2		
	Max. working pressure	MPa	1,6	1,6	1,6		
	Diameter	mm	Φ7	Φ7	Φ7		
Net dimensions (WxHxD)		mm	915x290x230	915x290x230	1072x315x230		
Packing size (WxHxD)		mm	1020x390x315	1020x390x315	1180x415x315		
Net weight		kg	12,7	12,7	14,9		
Gross weight		kg	17,3	16,3	18,6		
Water inlet/outlet pipe		inch	G3/4	G3/4	G3/4		
Drain pipe		mm	Φ20	Φ20	Φ20		
ADDITIONAL TECHNICAL INFORMATION							
Recommended power cable	Below 20 m	mm²	3x2,5	3x2,5	3x2,5		
Recommended air switch		A	B16	B16	B16		
EQUIPMENT							
Drain pump			no	no	no		
Max. lift (from bottom of ID)		mm	-	-	-		
Built-in 3-way valve			yes	yes	yes		
Alarm connector			yes (230V)	yes (230V)	yes (230V)		
ON/OFF connector			yes (dry-contact)	yes (dry-contact)	yes (dry-contact)		
Fresh air inlet			no	no	no		
BMS modbus RTU			yes	yes	yes		
STANDARD ACCESSORIES							
Water outlet joint			yes	yes	yes		
Clasp			yes	yes	yes		
Remote controller (IR)			R05	R05	R05		
OPTIONAL ACCESSORIES							
Wire controller			KJR-29B	KJR-29B	KJR-29B		
Central controller			SCM-30	SCM-30	SCM-30		

Note: H: High fan speed; M: Medium fan speed; L: Low fan speed. Cooling mode: entering air temperature 27 °C DB/19 °C WB, entering/leaving water temperature 7 °C /12 °C. Heating mode: entering air temperature 20 °C DB, enter water teperature 50 °C. Same water flow as in standard rating condition in cooling. The specification of products is subject to change based on further development of the units by the producer and can be changed without prior notice. Refer to rating label.

APPEARANCE AND DIMENSIONS OF INDOOR UNIT

FCU WALL-MOUNTED

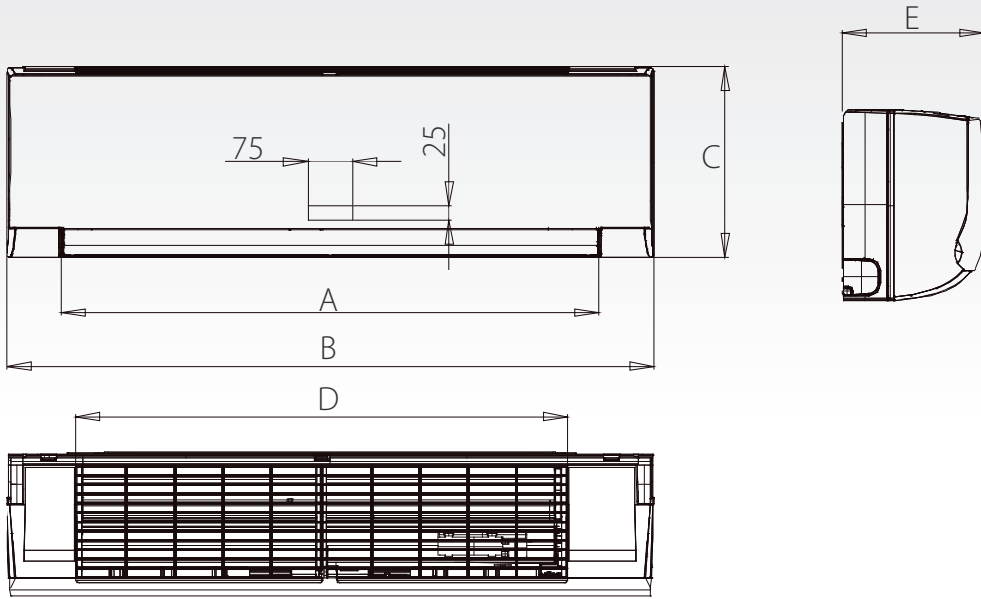

Model	A (mm)	B (mm)	C (mm)	D (mm)	E (mm)
SF-250HM2/400HM2	732	915	290	663	233
SF-600HM2	892	1072	315	813	237

RACK DIMENSIONS

FCU WALL-MOUNTED

SF-250/400HM2

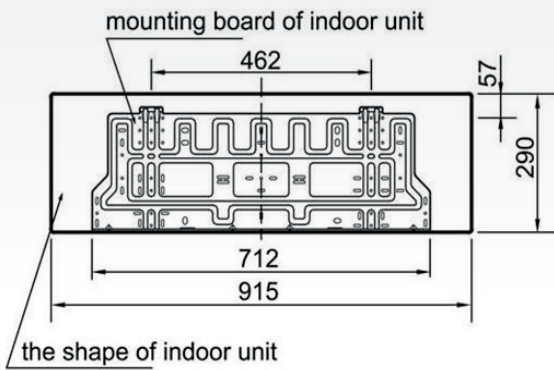

SF-600HM2

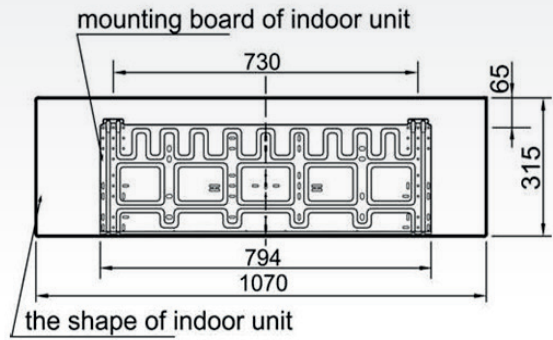

INDOOR UNITS

FCU SF2 DUCT 2 PIPES, 3 ROWS

MODEL			SF2-200D3	SF2-300D3	SF2-400D3	SF2-500D3	SF2-600D3
Power supply		V/Ph/Hz	220-240/1/50				
Air flow (H/M/L)		m³/h	377/301/226	542/424/305	735/602/446	789/635/475	1042/815/576
		CFM	222/177/133	319/249/179	432/354/262	464/374/279	613/479/339
Standard external static pressure		Pa	12Pa (default); 30/50Pa can be set through dial switch on PCB				
Cooling	Capacity (H/M/L)	kW	2,45/2,05/1,59	3,35/2,89/2,21	4,25/3,69/2,88	4,55/3,92/2,97	5,85/4,88/3,66
	Water flow rate	m³/h	0,41/0,35/0,28	0,59/0,49/0,37	0,76/0,63/0,49	0,80/0,67/0,54	1,00/0,84/0,65
	Water pressure drop	kPa	17,0/13,7/13,0	23,0/17,6/10,6	19,0/14,7/9,4	23,0/19,0/12,1	34,0/26,5/18,6
Heating	Capacity (H/M/L)	kW	2,68/2,24/1,83	3,95/3,25/2,51	5,00/4,31/3,36	5,50/4,38/3,20	6,90/5,66/4,21
	Water flow rate	m³/h	0,45/0,38/0,33	0,67/0,55/0,42	0,89/0,74/0,57	0,92/0,76/0,59	1,16/0,96/0,75
	Water pressure drop	kPa	17,0/13,1/11,9	25,0/18,1/11,2	21,0/15,9/9,9	25,0/19,9/12,0	38,0/28,7/18,6
Max. power input		W	17	25	34	37	64
Sound pressure level		dB(A)	39/33/25	37/31/23	43/38/30	45/39/31	50/44/34
Fan motor	Type		DC Motor	DC Motor	DC Motor	DC Motor	DC Motor
	Quantity		1	1	1	1	1
Fan	Type		Centrifugal, forward-curved blades				
	Quantity		1	2	2	2	2
Coil	Row		3	3	3	3	3
	Max. working pressure	MPa	1,6	1,6	1,6	1,6	1,6
	Diameter	mm	Φ7	Φ7	Φ7	Φ7	Φ7
Net dimensions (WxHxD)		mm	632x243x482	773x243x482	908x243x482	908x243x482	1003x243x482
Packing size (WxHxD)		mm	698x270x520	843x270x520	978x270x520	978x270x520	1073x270x520
Net weight		kg	14,0	17,2	19,2	19,2	21,7
Gross weight		kg	16,0	19,5	22,2	22,2	24,5
Water inlet/outlet pipe		inch	RC3/4	RC3/4	RC3/4	RC3/4	RC3/4
Drain pipe		inch	ZG3/4	ZG3/4	ZG3/4	ZG3/4	ZG3/4
ADDITIONAL TECHNICAL INFORMATION							
Recommended power cable	Bellow 20m	mm²	3x2,5	3x2,5	3x2,5	3x2,5	3x2,5
Recommended air switch		A	B16	B16	B16	B16	B16
EQUIPMENT							
Drain pump			no	no	no	no	no
Max. lift (from bottom of ID)		mm	-	-	-	-	-
Built-in 3-way valve			no	no	no	no	no
Control fan speed (H/M/L)			no	no	no	no	no
Control 2 or 3-way valve			yes (230V)	yes (230V)	yes (230V)	yes (230V)	yes (230V)
Alarm connector			no	no	no	no	no
ON/OFF connector			yes (dry-contact)	yes (dry-contact)	yes (dry-contact)	yes (dry-contact)	yes (dry-contact)
Fresh air inlet		mm	Φ92	Φ92	Φ92	Φ92	Φ92
BMS modbus RTU			yes	yes	yes	yes	yes
OPTIONAL ACCESSORIES							
Wire controller			SWC-61	SWC-61	SWC-61	SWC-61	SWC-61
Central controller			SCM-30	SCM-30	SCM-30	SCM-30	SCM-30
Control fan speed (H/M/L), ON/OFF, Alarm			SF2-DTK	SF2-DTK	SF2-DTK	SF2-DTK	SF2-DTK
Control fan speed (0-10V), valve control 0-10V			SF2-EC*	SF2-EC*	SF2-EC*	SF2-EC*	SF2-EC*

*SF2-EC require SF2-DTK

H: High fan speed, M: Medium fan speed, L: Low fan speed.

Cooling mode: entering air temperature 27°C DB/19°C WB, entering/leaving water temperature 7°C /12°C, with air return plenum and filter.

Heating mode: entering air temperature 20°C DB, entering/leaving water temperature 45/40°C, with air return plenum and filter.

Sound pressure level is tested in the semi-anechoic room with background noise is 17,5dB (A), when the unit is without accessories and running in dry condition, at 1m below & 1m front the vertical center line of the unit with 1m outlet duct.

Air flow is tested under dry condition, 20°C DB, with air return plenum and filter.

Left and right unit can be changed in the field, but cooling should be multiplied with correction factor 0,9.

The specification of products is subject to change based on further development of the units by the producer and can be changed without prior notice. Refer to rating label.

INDOOR UNITS

FCU SF2 DUCT 2 PIPES, 3 ROWS

MODEL			SF2-700D3	SF2-800D3	SF2-1000D3	SF2-1200D3	SF2-1400D3
Power supply		V/Ph/Hz	220-240/1/50				
Air flow (H/M/L)		m³/h	1218/1031/844	1381/1093/816	1665/1204/740	1720/1379/1028	2202/1943/1670
		CFM	716/606/496	812/643/480	979/708/435	1012/811/605	1295/1143/982
Standard external static pressure		Pa	12Pa (default); 30/50Pa can be set through dial switch on PCB				
Cooling	Capacity (H/M/L)	kW	6,50/6,04/5,09	8,02/6,65/5,37	9,05/7,10/4,97	10,08/7,25/6,02	11,11/10,58/9,77
	Water flow rate	m³/h	1,19/1,05/0,91	1,36/1,17/0,94	1,58/1,26/0,88	1,69/1,44/1,16	2,02/1,84/1,71
	Water pressure drop	kPa	22,0/19,0/15,6	32,00/26,06/18,05	32,00/22,01/11,71	27,0/20,7/14,0	33,00/29,29/25,92
Heating	Capacity (H/M/L)	kW	7,60/6,96/5,81	9,40/7,36/5,82	11,00/8,02/5,41	11,83/8,32/6,78	12,67/11,98/10,59
	Water flow rate	m³/h	1,38/1,22/1,05	1,53/1,26/0,98	1,78/1,36/0,92	1,94/1,64/1,30	2,23/2,04/1,84
	Water pressure drop	kPa	25,0/21,1/16,2	41,0/25,3/16,4	33,0/21,6/10,9	26,0/20,1/13,3	34,00/30,41/25,26
Max. power input		W	75	72	119	119	119
Sound pressure level	H/M/L	dB(A)	51/45/40	50/43/36	55/46/34	50/43/34	53/50/47
Fan motor	Type		DC Motor	DC Motor	DC Motor	DC Motor	DC Motor
	Quantity		1	1	1	1	2
Fan	Type		Centrifugal, forward-curved blades				
	Quantity		2	3	3	4	4
Coil	Row		3	3	3	3	3
	Max. working pressure	MPa	1,6	1,6	1,6	1,6	1,6
	Diameter	mm	Φ7	Φ7	Φ7	Φ7	Φ7
Net dimensions (WxHxD)		mm	1178x243x482	1368x243x482	1368x243x482	1658x243x482	1898x243x482
Packing size (WxHxD)		mm	1248x270x520	1438x270x520	1438x270x520	1728x270x520	1968x270x520
Net weight		kg	23,5	27,7	27,7	33,8	37
Gross weight		kg	26,8	30,7	30,7	38,3	41,5
Water inlet/outlet pipe		inch	RC3/4	RC3/4	RC3/4	RC3/4	RC3/4
Drain pipe		inch	ZG3/4	ZG3/4	ZG3/4	ZG3/4	ZG3/4
ADDITIONAL TECHNICAL INFORMATION							
Recommended power cable	Bellow 20m	mm²	3x2,5	3x2,5	3x2,5	3x2,5	3x2,5
Recommended air switch		A	B16	B16	B16	B16	B16
EQUIPMENT							
Drain pump			no	no	no	no	no
Max. lift (from bottom of ID)		mm	-	-	-	-	-
Built-in 3-way valve			no	no	no	no	no
Control fan speed (H/M/L)			no	no	no	no	no
Control 2 or 3-way valve			yes (230V)	yes (230V)	yes (230V)	yes (230V)	yes (230V)
Alarm connector			no	no	no	no	no
ON/OFF connector			yes (dry-contact)	yes (dry-contact)	yes (dry-contact)	yes (dry-contact)	yes (dry-contact)
Fresh air inlet		mm	Φ92	Φ92	Φ92	Φ92	Φ92
BMS modbus RTU			yes	yes	yes	yes	yes
OPTIONAL ACCESSORIES							
Wire controller			SWC-61	SWC-61	SWC-61	SWC-61	SWC-61
Central controller			SCM-30	SCM-30	SCM-30	SCM-30	SCM-30
Control fan speed (H/M/L), ON/OFF, Alarm			SF2-DTK	SF2-DTK	SF2-DTK	SF2-DTK	SF2-DTK
Control fan speed (0-10V), valve control 0-10V			SF2-EC*	SF2-EC*	SF2-EC*	SF2-EC*	SF2-EC*

*SF2-EC require SF2-DTK

H: High fan speed, M: Medium fan speed, L: Low fan speed.

Cooling mode: entering air temperature 27°C DB/19°C WB, entering/leaving water temperature 7°C /12°C, with air return plenum and filter.

Heating mode: entering air temperature 20°C DB, entering/leaving water teperature 45/40°C, with air return plenum and filter.

Sound pressure level is tested in the semi-anechoic room with background noise is 17,5dB (A), when the unit is without accessories and running in dry condition, at 1m below & 1m front the vertical center line of the unit with 1m outlet duct.

Air flow is tested under dry condition, 20°C DB, with air return plenum and filter.

Left and right unit can be changed in the field, but cooling should be multiplied with correction factor 0,9.

The specification of products is subject to change based on further development of the units by the producer and can be changed without prior notice. Refer to rating label.

APPEARANCE AND DIMENSIONS OF FAN COIL UNIT

FCU SF2 DUCT 2 PIPES, 3 ROWS

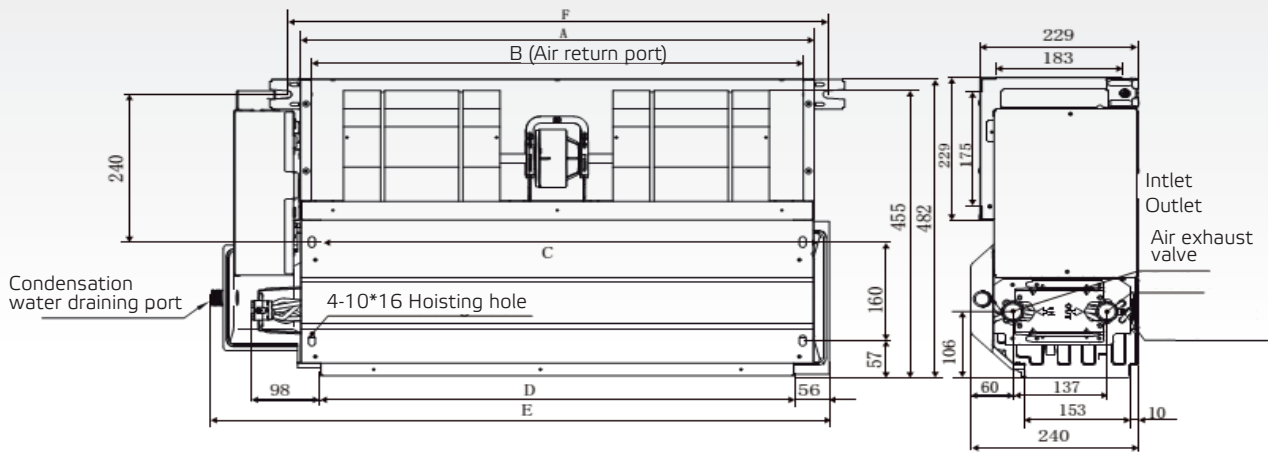

Size \ Model	200-Model	300-Model	400-Model 500-Model	600-Model	700-Model	800-Model 1000-Model	1200-Model	1400-Model
A	475	620	755	850	1025	1215	1505	1745
B	443	588	723	818	993	1183	1473	1713
C	443	588	723	818	993	1183	1473	1713
D	415	560	695	790	965	1155	1445	1685
E	627	772	907	1002	1177	1367	1657	1897
F	513	658	793	888	1063	1253	1543	1783

INDOOR UNITS

FCU DUCT 4 PIPES

MODEL			SF-200D4	SF-300D4	SF-400D4	SF-500D4
Power supply		V/Ph/Hz	220-240/1/50			
Air flow (H/M/L)		m³/h	320/210/140	450/340/280	530/390/260	690/470/370
		CFM	190/120/85	270/200/170	320/230/160	410/280/220
Standard external static pressure		Pa	12Pa (default); 30/50Pa can be set through dial switch on PCB			
Cooling	Capacity (H/M/L)	kW	1,4/1,1/0,8	2,2/1,7/1,5	2,5/2,0/1,5	3,0/2,4/1,9
	Water flow rate	m³/h	0,27	0,38	0,47	0,54
	Water pressure drop	kPa	10,2	10,5	11,3	13,6
Heating	Capacity (H/M/L)	kW	2,1/1,7/1,4	3,0/2,6/2,1	3,7/3,2/2,5	4,4/3,6/3,0
	Water pressure drop	kPa	8,9	9,1	10,1	11,7
Max. power input		W	16	21	28	36
Sound pressure level	12Pa (H/M/L)	dB(A)	35/25/23	36/29/23	38/32/24	43/35/27
	30Pa (H/M/L)	dB(A)	41/32/25	39/30/25	44/38/28	46/37/30
	50Pa (H/M/L)	dB(A)	43/34/26	44/36/26	47/41/28	48/42/33
Fan motor	Type		DC Motor	DC Motor	DC Motor	DC Motor
	Quantity		1	1	1	2
Fan	Type		Centrifugal, forward-curved blades			
	Quantity		2	2	2	2
Coil	Row		3	3	3	3
	Max. working pressure	MPa	1,6	1,6	1,6	1,6
	Diameter	mm	φ9,52	φ9,52	φ9,52	φ9,52
Net dimensions (WxHxD)		mm	741x241x522	841x241x522	941x241x522	941x241x522
Packing size (WxHxD)		mm	790x260x550	890x260x550	990x260x550	990x260x550
Net weight		kg	17,2	19,5	21,5	21,5
Gross weight		kg	20,2	22,5	24,5	24,5
Water inlet/outlet pipe		inch	RC3/4	RC3/4	RC3/4	RC3/4
Drain pipe		inch	R3/4	R3/4	R3/4	R3/4
ADDITIONAL TECHNICAL INFORMATION						
Recommended power cable	Below 20 m	mm²	3x2,5	3x2,5	3x2,5	3x2,5
Recommended air switch		A	B16	B16	B16	B16
EQUIPMENT						
Drain pump			no	no	no	no
Max. lift (from bottom of ID)		mm	-	-	-	-
Built-in 3-way valve			no	no	no	no
Control fan speed (H/M/L)			yes (230V)	yes (230V)	yes (230V)	yes (230V)
Alarm connector			yes (230V)	yes (230V)	yes (230V)	yes (230V)
ON/OFF connector			no	no	no	no
Fresh air inlet		mm	φ92	φ92	φ92	φ92
BMS modbus RTU			require SWC-86A or FCUKZ-04			
STANDARD ACCESSORIES						
Water extend drip tray			yes	yes	yes	yes
OPTIONAL ACCESSORIES						
Wire controller			KJR-18B	KJR-18B	KJR-18B	KJR-18B
Wire controller with modbus RTU			SWC-86A	SWC-86A	SWC-86A	SWC-86A
Central controller			SCM-30 (require FCUKZ-04)	SCM-30 (require FCUKZ-04)	SCM-30 (require FCUKZ-04)	SCM-30 (require FCUKZ-04)
Connection kit			FCUKZ-04	FCUKZ-04	FCUKZ-04	FCUKZ-04

H: High fan speed; M: Medium fan speed; L: Low fan speed.

Cooling mode: entering air temperature 27°C DB/19°C WB, entering/leaving water temperature 7°C /12°C. Heating mode: entering air temperature 20°C DB, enter water teperature 50°C. Same water flow as in standard rating condition in cooling.

The specification of products is subject to change based on further development of the units by the producer and can be changed without prior notice. Refer to rating label.

APPEARANCE OF INDOOR UNITS

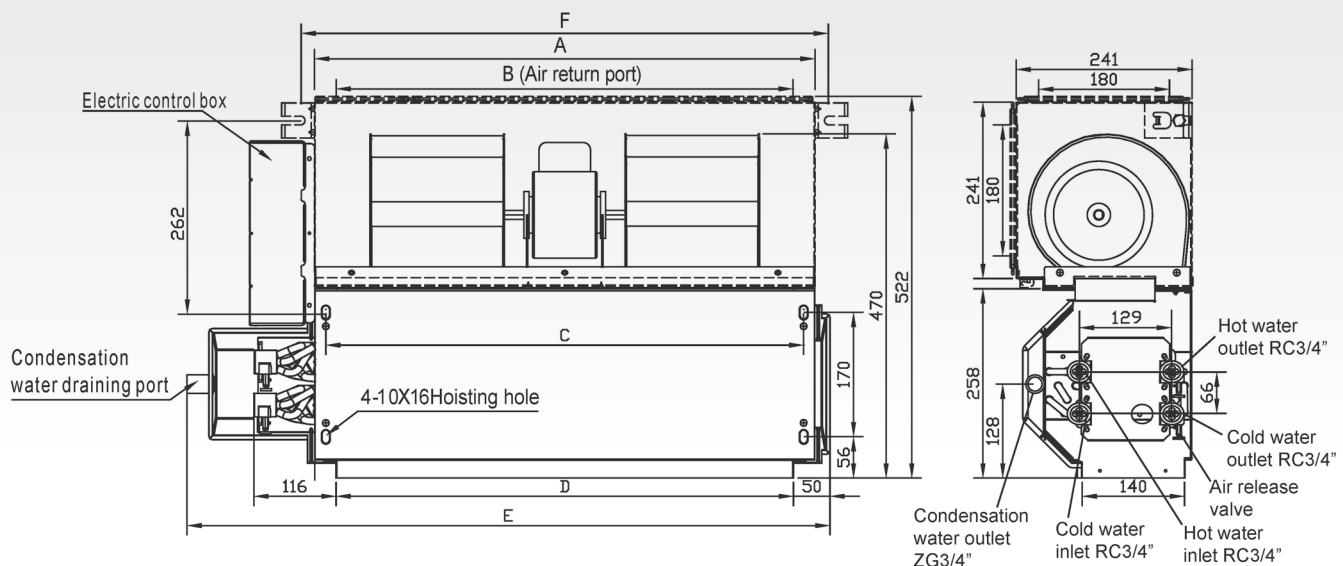

INDOOR UNITS

FCU DUCT 4 PIPES

MODEL			SF-600D4	SF-800D4	SF-1000D4	SF-1200D4		
Power supply		V/Ph/Hz	220-240/1/50					
Air flow (H/M/L)		m³/h	900/670/440	1240/840/670	1610/1160/790	1850/1400/970		
		CFM	530/400/260	730/500/400	950/690/470	1090/830/570		
Standard external static pressure		Pa	12Pa (default); 30/50Pa can be set through dial switch on PCB					
Cooling	Capacity (H/M/L)	kW	4,2/3,5/2,5	5,3/4,1/3,1	6,7/5,4/3,9	8,2/6,5/4,6		
	Water flow rate	m³/h	0,73	0,93	1,18	1,40		
	Water pressure drop	kPa	15,3	12,8	21,6	34,9		
Heating	Capacity (H/M/L)	kW	5,7/4,8/3,4	6,8/5,5/4,6	8,2/6,9/5,2	10,1/8,6/6,8		
	Water pressure drop	kPa	12,7	12	15,5	25,73		
Max. power input		W	45	57	87	95		
Sound pressure level	12Pa (H/M/L)	dB(A)	46/39/30	46/38/30	48/41/31	47/40/30		
	30Pa (H/M/L)	dB(A)	49/41/33	49/43/33	49/42/33	50/42/34		
	50Pa (H/M/L)	dB(A)	51/44/39	52/45/37	51/44/35	53/45/37		
Fan motor	Type		DC Motor	DC Motor	DC Motor	DC Motor		
	Quantity		1	2	2	2		
Fan	Type		Centrifugal, forward-curved blades					
	Quantity		2	4	4	4		
Coil	Row		3	3	3	3		
	Max. working pressure	MPa	1,6	1,6	1,6	1,6		
	Diameter	mm	φ9,52	φ9,52	φ9,52	φ9,52		
Net dimensions (WxHxD)		mm	1161x241x522	1461x241x522	1566x241x522	1856x241x522		
Packing size (WxHxD)		mm	1210x260x550	1510x260x550	1615x260x550	1905x260x550		
Net weight		kg	24,2	33,5	35,2	39,7		
Gross weight		kg	27,7	37,7	39,7	44,9		
Water inlet/outlet pipe		inch	RC3/4	RC3/4	RC3/4	RC3/4		
Drain pipe		inch	R3/4	R3/4	R3/4	R3/4		
ADDITIONAL TECHNICAL INFORMATION								
Recommended power cable	Below 20 m	mm²	3x2,5	3x2,5	3x2,5	3x2,5		
Recommended air switch		A	B16	B16	B16	B16		
EQUIPMENT								
Drain pump			no	no	no	no		
Max. lift (from bottom of ID)		mm	-	-	-	-		
Built-in 3-way valve			no	no	no	no		
Control fan speed (H/M/L)			yes (230V)	yes (230V)	yes (230V)	yes (230V)		
Alarm connector			yes (230V)	yes (230V)	yes (230V)	yes (230V)		
ON/OFF connector			no	no	no	no		
Fresh air inlet		mm	φ92	φ92	φ92	φ92		
BMS modbus RTU			require SWC-86A or FCUKZ-03					
STANDARD ACCESSORIES								
Water extend drip tray			yes	yes	yes	yes		
OPTIONAL ACCESSORIES								
Wire controller			KJR-18B	KJR-18B	KJR-18B	KJR-18B		
Wire controller with modbus RTU			SWC-86A	SWC-86A	SWC-86A	SWC-86A		
Central controller			SCM-30 (require FCUKZ-04)	SCM-30 (require FCUKZ-04)	SCM-30 (require FCUKZ-04)	SCM-30 (require FCUKZ-04)		
Connection kit			FCUKZ-04	FCUKZ-04	FCUKZ-04	FCUKZ-04		

H: High fan speed; M: Medium fan speed; L: Low fan speed.

Cooling mode: entering air temperature 27°C DB/19°C WB, entering/leaving water temperature 7°C /12°C. Heating mode: entering air temperature 20°C DB, enter water teperature 50°C. Same water flow as in standard rating condition in cooling. The specification of products is subject to change based on further development of the units by the producer and can be changed without prior notice. Refer to rating label.

DIMENSIONS OF INDOOR UNITS

Model	SF-200D4	SF-300D4	SF-400D4 SF-500D4	SF-600D4	SF-800D4	SF-1000D4	SF-1200D4
A (mm)	545	645	745	965	1265	1370	1660
B (mm)	485	585	685	905	1205	1310	1600
C (mm)	513	613	713	933	1233	1338	1628
D (mm)	485	585	685	905	1205	1310	1600
E (mm)	741	841	941	1161	1461	1566	1856
F (mm)	583	683	783	1003	1303	1408	1698

INDOOR UNITS

FCU FLOOR CEILING 2 PIPES

MODEL			SF-250F3	SF-350F3	SF-500F3	SF-700F3	SF-800F3
Power supply		V/Ph/Hz	220-240/1/50				
Air flow (H/M/L)		m³/h	400/315/190	595/470/340	790/580/410	1190/855/505	1360/1015/685
		CFM	235/185/112	350/276/200	465/341/241	700/503/297	800/597/403
Cooling	Capacity (H/M/L)	kW	2,35/1,94/1,19	3,5/2,89/2,22	4,3/3,48/2,71	5,60/4,47/3,14	7,35/6,12/4,57
	Water flow rate	m³/h	0,41/0,35/0,23	0,61/0,51/0,40	0,77/0,73/0,62	1,01/0,80/0,56	1,28/1,10/0,81
	Water pressure drop	kPa	13,3/9,98/4,59	34,1/24,63/15,39	54,2/36,22/22,78	50,7/33,38/17,73	44,1/33,7/19,41
Heating	Capacity (H/M/L)	kW	2,6/2,11/1,34	3,5/2,87/2,19	4,3/3,43/2,6	6,00/4,77/3,36	8,05/6,46/4,71
	Water flow rate	m³/h	0,47/0,39/0,24	0,68/0,56/0,43	0,85/0,81/0,68	1,14/0,92/0,64	1,40/1,14/0,84
	Water pressure drop	kPa	14,3/10,33/4,5	35,1/24,41/14,82	54,3/36,9/22,3	55,5/37,66/19,27	46,9/31,9/18,16
Max. power input		W	17	26	50	96	113
Sound pressure level (H/M/L)		dB(A)	29/24/18	38/32/23	46/38/30	50/42/31	50/43/33
Sound power level (H/M/L)		dB(A)	43/37/29	52/44/36	59/51/43	64/56/45	63/58/49
Fan motor	Type		DC Motor	DC Motor	DC Motor	DC Motor	DC Motor
	Quantity		1	1	1	1	1
Fan	Type		Centrifugal, forward-curved blades				
	Quantity		2	2	2	3	3
Coil	Row		3	3	3	3	3
	Max. working pressure	MPa	1,6	1,6	1,6	1,6	1,6
	Diameter	mm	Ø7,94	Ø7,94	Ø7,94	Ø7,94	Ø7,94
Body	Net dimensions (WxHxD)	mm	1020x495x200	1240x495x200	1240x495x200	1360x495x200	1360x591x200
	Packing size (WxHxD)	mm	1125x595x300	1345x595x300	1345x595x300	1465x595x300	1465x695x300
	Net weight	kg	21,5	25,5	25,5	28,5	32,5
	Gross weight	kg	27,5	32,5	32,5	36	41
Water inlet/outlet pipe		inch	G3/4	G3/4	G3/4	G3/4	G3/4
Drain pipe		mm	Ø18,5	Ø18,5	Ø18,5	Ø18,5	Ø18,5
ADDITIONAL TECHNICAL INFORMATION							
Recommended power cable	Below 20 m	mm²	3x2,5	3x2,5	3x2,5	3x2,5	3x2,5
Recommended air switch		A	B16	B16	B16	B16	B16
EQUIPMENT							
Drain pump			no	no	no	no	no
Max. lift (from bottom of ID)		mm	-	-	-	-	-
Built-in 3-way valve			no	no	no	no	no
Control fan speed (H/M/L)			yes (230V)	yes (230V)	yes (230V)	yes (230V)	yes (230V)
Control 2 or 3-way valve			yes (230V)	yes (230V)	yes (230V)	yes (230V)	yes (230V)
Alarm connector			yes (230V)	yes (230V)	yes (230V)	yes (230V)	yes (230V)
ON/OFF connector			yes (dry-contact)	yes (dry-contact)	yes (dry-contact)	yes (dry-contact)	yes (dry-contact)
Fresh air inlet		mm	no	no	no	no	no
BMS modbus RTU			yes	yes	yes	yes	yes
STANDARD ACCESSORIES							
Water outlet joint			yes	yes	yes	yes	yes
Clasp			yes	yes	yes	yes	yes
OPTIONAL ACCESSORIES							
Wire controller			KJRP-75A, KJR-18B	KJRP-75A, KJR-18B	KJRP-75A, KJR-18B	KJRP-75A, KJR-18B	KJRP-75A, KJR-18B
Central controller			SCM-30	SCM-30	SCM-30	SCM-30	SCM-30

Note: H: High fan speed; M: Medium fan speed; L: Low fan speed. Cooling mode: entering air temperature 27 °C DB/19 °C WB, entering/leaving water temperature 7 °C /12 °C. Heating mode: entering air temperature 20 °C DB, enter water teperature/water flow 45 °C. (same water flow as in standard rating condition in cooling). The specification of products is subject to change based on further development of the units by the producer and can be changed without prior notice. Refer to rating label.

APPEARANCE AND DIMENSIONS OF INDOOR UNIT

FCU FLOOR CEILING 2 PIPES

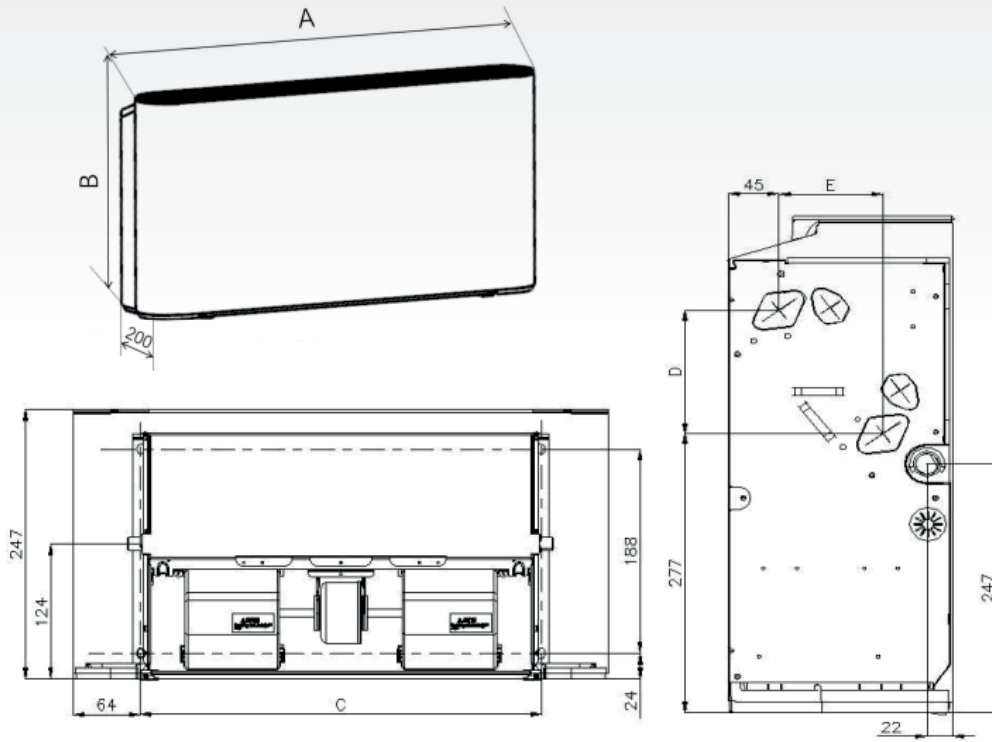

Size / Model	A	B	C	D	E
SF-250F3	1020	495	793	123	93
SF-350F3	1240	495	973	123	93
SF-500F3	1240	495	973	123	93
SF-700F3	1360	495	1093	123	93
SF-800F3	1360	591	1093	219	102

EXPLANATORY NOTES

GENERAL

All dimensions on pictures are in millimeters (mm) in this catalogue.

CONDITIONS UNDER WHICH HAS BEEN PERFORMED MEASUREMENTS OF TECHNICAL PARAMETERS:

OUTDOOR UNITS SDV6 and SDV5

- 1) Capacities are based on the following conditions: Cooling: Indoor temperature 27°C DB / 19°C WB; Outdoor temperature 35°C DB / 24°C WB. Heating: Indoor temperature 20°C DB / 15°C WB; Outdoor temperature 7°C DB / 6°C WB.
Piping length: Interconnecting piping length is 7,5m, level difference is 0m.
- 2) Connection piping diameter is based on the condition that the total equivalent liquid length is less than 90m.
When the total equivalent liquid length is more than 90m, please refer to technical manual to choose the connection piping diameter.
- 3) Sound values are measured in a semi-anechoic room, at a position 1m in front of the unit and 1,3m above the floor.
- 4) The above data may be changed without notice for further improvement on quality and performance.

INDOOR UNITS SDV6

- 1) Indoor temperature 27°C DB, 19°C WB; outdoor temperature 35°C DB; equivalent refrigerant piping length 7,5m with zero level difference
- 2) Indoor temperature 20°C DB; outdoor temperature 7°C DB, 6°C WB; equivalent refrigerant piping length 7,5m with zero level difference.
- 3) Fan motor speed and air flow rate are from the highest speed to the lowest speed, total 7 rates for each model
- 4) Sound pressure level is from highest level to lowest level, total 7 levels for each model. Sound pressure level is measured 1,4m or 1m below the unit in a semi-anechoic chamber.

SH/MH/H/M/L/ML/SL - super high / mid high / high / mid / low / mid low / super low

EXV - electromagnetic expansion valve

R410A (50% HFC-32, 50% HFC-125), GWP 2088

R32 (100% HFC-32), GWP 675

IDU = ID = indoor unit, **ODU = OD** = outdoor unit

