



FULL DC INVERTER SYSTEMS INSTALLATION MANUAL

INDOOR CASSETTE UNITS SDV5-17-45CA

COMMERCIAL AIR CONDITIONERS SDV5

Original instructions

IMPORTANT NOTE:

Read this manual carefully before installing or operating your new air conditioning unit. Make sure to save this manual for future reference.

CONTENTS

PAGE

PRECAUTIONS.....	1
INSTALLATION INFORMATION.....	2
INSPECTING AND HANDLING THE UNIT.....	2
ATTACHED FITTINGS.....	3
INDOOR UNIT INSTALLATION.....	4
INSTALL THE CONNECTION PIPE.....	8
REFRIGERANT PIPE CONNECTION.....	8
CONNECT THE DRAINAGE PIPE.....	10
ELECTRICAL CONNECTION.....	11
CONTROL OPERATION.....	13
TEST OPERATION.....	15

1. PRECAUTIONS

- Comply with local, national and international laws and regulations.
- Read "PRECAUTIONS" carefully before installation.
- The following precautions include important safety items. Strictly follow them.
- Keep this manual with the owner's manual in a handy place for future reference.

The safety precautions listed here are divided into two categories. Read both carefully.



WARNING

Failure to observe a warning may result in death.



CAUTION

Failure to observe a caution may result in injury or damage to the equipment.

After completing the installation, ensure that the unit operates properly during start-up. Please instruct the customer on how to operate the unit and keep it well maintained. Inform customers that they should store this installation manual and the owner's manual for future reference.



WARNING

Only trained and qualified service personnel can install, repair or service the equipment.

Improper installation, repair, and maintenance may result in electric shocks, short-circuit, leaks, fire or other damage to the equipment.

Strictly perform installation according to these installation instructions.

Faulty installation may cause water leaks, electric shocks and fires.

When installing the unit in a small room, take measures against the refrigerant from exceeding allowable safety limits in the event of refrigerant leaks. Contact the place of purchase for more information. Excessive refrigerant in a closed ambient environment can lead to oxygen deficiency.

Only use the attached accessories parts and specified parts for installation.

Otherwise, it will cause the unit to fall and may also cause water leaks, electric shocks, or fire.

Install in a strong location which that can bear the unit's weight.

If the location is not strong enough or if installation is not properly done, the unit may fall and cause injury.

The unit must be installed 2300mm above the floor.

The unit must not be installed in a laundry room.

Before obtaining access to terminals, all supply circuits must be disconnected.

The unit must be positioned where the plug is accessible.

The enclosure of the unit must be marked by words or symbols to show direction of the refrigerant flow.

Electrical work should comply with relevant national and local standard, regulations, and this manual . An independent circuit and single outlet must be used.

If electrical circuit capacity is not sufficient or defective, electric shock or fire may result.

Use the specified wire, connect it tightly and clamp it, so that no external force will be acted on the terminal.

If connection or fixing is imperfect, over-heating or a fire at the connection point may occur.

Wiring routing must be properly arranged so that the control board cover is fixed properly.

If the control board cover is fixed imperfectly, it may cause overheating at the connection point of the terminal, a fire, or electric shocks.

If the power wire is damaged, it must be replaced by the manufacture or its service agent or a similarly qualified person to avoid a hazard.

A disconnection switch must be installed on all poles as fixed wiring with a contact separation of at least 3mm in all poles.

When carrying out piping connection, do not to let air go into the refrigeration piping system.

Otherwise, it will lower capacity and may cause abnormally high pressure in the refrigeration cycle, an explosion, and injury.

Do not modify the length of the power supply wire or use the extension wire. Do not share the single outlet with other electrical appliances.

Otherwise, it may cause a fire or electric shocks.

The temperature of the refrigerant circuit will be high. Keep the interconnection wire away from the copper pipe.

The unit must be installed in accordance with national wiring regulations.

A disconnection switch must be installed on all poles as fixed wiring with a contact separation of at least 3mm. A residual current device (RCD) with a rating above 10 mA must be incorporated in the fixed wiring according to national regulations.

The power cord type designation is H05RN-R/H07RN-F or above.

Consider environmental factors, such as typhoons and earthquakes, during installation.

Improper installation may result in the equipment falling.

If refrigerant leakage occurs, ventilate the area immediately.

Toxic gas may be produced if the refrigerant comes into contact with fire.

After completing installation, ensure that the refrigerant does not leak.

Toxic gas may be produced if the refrigerant leaks into the room and comes into contact with a source of fire such as a fan heater, stove or cooker.



CAUTION

Ground the air conditioner.

Do not connect the grounding wire to any pipes, lightning rods or telephone grounding wires. Incomplete grounding may result in electric shocks.

Be sure to install an earth leakage breaker.

Failure to install an earth leakage breaker may result in electric shocks.

Connect the outdoor unit's wires, then connect the indoor unit's wires.

Do not connect the air conditioner to the power supply until installation (including wiring and piping) is completed.

Follow the instructions in this installation manual, and install drain piping to ensure proper drainage and insulation to prevent condensation.

Improper drainage piping may result in water leakage and property damage.

Power wiring and communication wiring of indoor units and outdoor units should be at least 1 meter away from TVs and radios to prevent interference or noise.

The required distance should be larger if the intensity of radio waves is higher.

The unit is not intended for use by young children or infirm persons without supervision.

The appliance is not intended for use by young children or the elderly without supervision.

Young children should be supervised to ensure that they do not play with the appliance

Do not install the air conditioner in the following locations:

- Where a large amount of lubricant oil such as petrolatum is used.
- Where high salinity in the air exists, e.g., in coastal areas.
- Where there is caustic gas (e.g., sulfide) in the air (near a hot spring).
- Where there are strong vibrations (in factories).
- In buses or cabinets.
- Where oil vapor is produced, e.g., kitchen
- Where there are strong electromagnetic waves.
- Where there are flammable materials or gases.
- Where acid or alkaline liquid evaporates.
- Avoid narrow spaces that are sensitive to noise.
- Other special conditions.

2. INSTALLATION INFORMATION

To install the unit properly, please read this Installation Manual.

The air conditioner must be installed by qualified personnel.

When installing the indoor unit or its piping, follow this manual as strictly as possible.

If the air conditioner is installed on a metal part of the building, it must be electrically insulated according to the relevant standards for electrical appliances.

When all the installation work is completed, please turn on the power only after it has been thoroughly checked.

Notice will not be given regarding any changes to this manual due to product improvements.

INSTALLATION ORDER

- Select the location;
- Install the indoor unit;
- Install the outdoor unit;
- Install the connecti
- Connect the drainage pipe;
- Wiring;
- Test operation.

3. INSPECTING AND HANDLING THE UNIT

At delivery, the package should be checked and any damage should be reported immediately to the service agent.

When handling the unit, take into account the following:



- 1











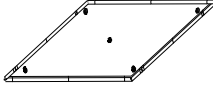

Keep the unit upright to avoid compressor damage.

- 2 Choose the path along which the unit is to be brought in advance.
- 3 Move this unit in its original packaging as far as possible.
- 4 When lifting the unit, always use protectors to prevent belt damage and pay attention to the position of the unit's center of gravity.

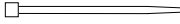
4. ATTACHED FITTINGS

Please check whether all the following fittings have been included. If there are spare fittings, please store them carefully.

Table 4-1

	Name	Shape	Four-way Cassette (compact)
Installation Fittings	1. Installation paper board		1
Tubing & Fittings	2. Soundproof / insulation sheath		2
Drainage pipe Fittings	3. Flexible hose tube		1
	4. Outlet pipe sheath		1
	5. Outlet pipe clasp		1
	6. Tightening band		5
Others	7. Installation manual	This manual	1
	9. Weak electric cable group		1
	10. Copper nut (Used for pipe connecting in installation)		1
	11. PVC sleeve Φ30		2
	12. PVC sleeve Φ20		1
	13. Tightening band		8

5. INDOOR UNIT INSTALLATION

5.1 Installation place

(Refer to Fig.5-1, Fig.5-2, Fig.5-3 for specifications.)

The indoor unit should be installed in a location that meets the following requirements:

- Not suitable for narrow spaces or areas that are sensitive to noise.
- Ensure that there is enough room for installation and maintenance.
- Ensure the ceiling is horizontal, and its structure can bear the weight of the indoor unit after cutting any holes or performing other installation-related work.
- The outlet and the inlet must not be impeded and there must be minimal influence from the outside air.
- The air flow extends throughout the room.
- The connection pipe and drainage pipe can be extracted easily.
- There is no direct radiation from heaters.
- Do not install it in a place where the air contains a lot of salt. If this can't be avoided, choose an anticorrosive model.



CAUTION

Keep the indoor unit, outdoor unit, power supply wire, and transmission wire at least 1000 mm away from televisions and radios. This is to prevent image interference and noise. (Noise may be generated depending on the conditions under which the electric wave is generated, even if 1000 mm distance is maintained.)

5.2 Install the main body

■ The existing ceiling (to be horizontal)

A Cut a quadrangular hole 600×600 mm in the ceiling according to the shape of the installation paper board. (Refer to Fig.5-3, Fig.5-4)

- The center of the hole should be in the same position the air conditioner body's center.
- Determine the lengths and outlets of the connection pipe, drainage pipe and wires.
- To balance the ceiling and to avoid vibrations, strengthen the ceiling if necessary.

B Select the position of installation hooks according to the hook holes on the installation board.

- Drill four holes of $\varnothing 12\text{mm}$, 45-50mm deep at the selected positions on the ceiling. Then embed the expansible hooks (fittings).
- Face the concave side of the installation hooks toward the expansible hooks. Determine the length of the installation hooks from the height of ceiling. Then cut off the unnecessary part.
- If the ceiling is extremely high, determine the length of the installation hook according to facts.
- Cut the installation hook open in the middle position, then use an appropriate length of reinforcing rods ($\varnothing 12\text{mm}$) to weld it together.

The length can be calculated from (Refer to Fig.5-4):

$$\text{Length} = 210 \text{ mm} + L \text{ (In general, L is 30-40mm)}$$

C Adjust the hexangular nuts on the four installation hooks evenly to ensure the body is balanced.

- If the drainage pipe is faulty, leaks may be caused by a malfunction of the water-level switch.
- Adjust the position to ensure the gaps between the body and the four sides of ceiling are even. The body's lower part should sink into the ceiling 10-12 mm. (Refer to Fig.5-5)

- Use the transparent hose filled with water to check the lever of the main body from the four sides or diagonal line direction. The lever indicator can check the lever from the four sides of the main body. (Refer to Fig.5-6)

- Locate the air conditioner firmly by tightening the nuts after adjusting the body's position well.

■ Newly built houses and ceilings

- 1 In the case of a newly built house, the hook can be embedded in advance (Refer to point B mentioned above). But it should be strong enough to bear the indoor unit and not become loose because the concrete has shrunk.
- 2 After installing the body, fasten the installation paper board onto the air conditioner with bolts (M5X20) to pre-determine the sizes and positions of the hole opening on ceiling. (Refer to Fig.5-8)
- Please guarantee the horizontal flatness of the ceiling when installing it
- Refer to point A mentioned above for others.
- 3 Refer to point C mentioned above for installation.
- 4 Remove the installation paper board.



CAUTION

After installing the body, the four bolts (M6x12) must be fastened to the air conditioner to ensure the body is grounded well.

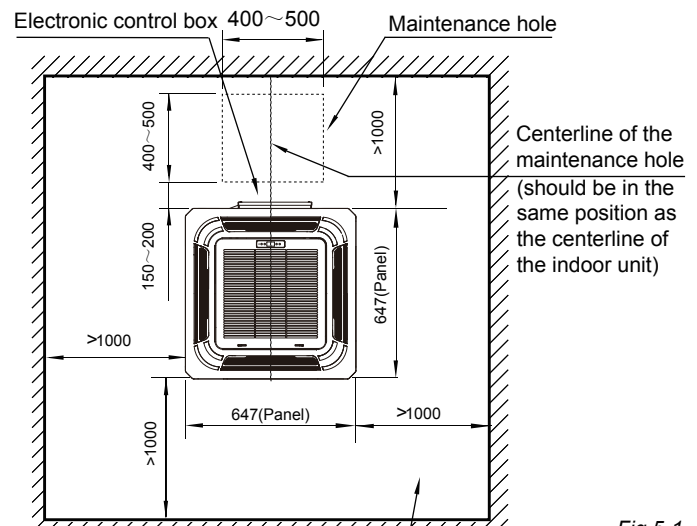

Fig.5-1

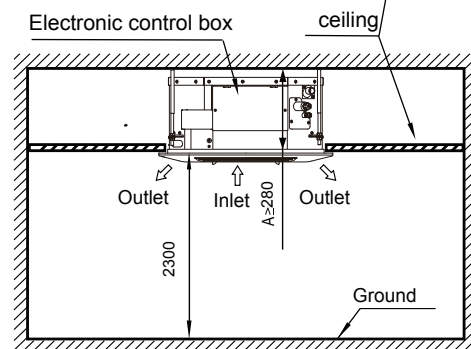

Fig.5-2

Necessary room for installation. Unit: mm

■ Reserve a maintenance hole for subsequent maintenance

When installing the unit, leave a maintenance hole beside the electronic control box in the ceiling in advance for maintenance. Its dimensions and position are shown in Fig.5-1. The hole should be sealed by a cover or other decorative materials. Ensure the cover of the hole can be disassembled when the indoor unit needs maintenance.

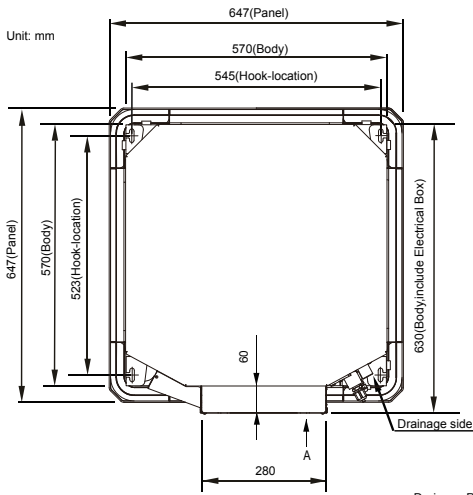

Fig. 5-3

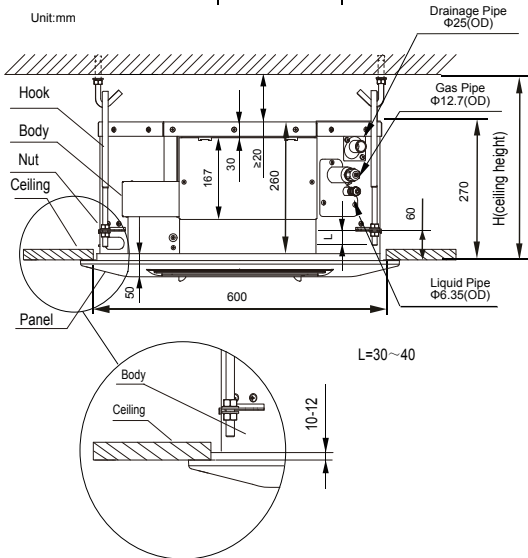

Fig. 5-4

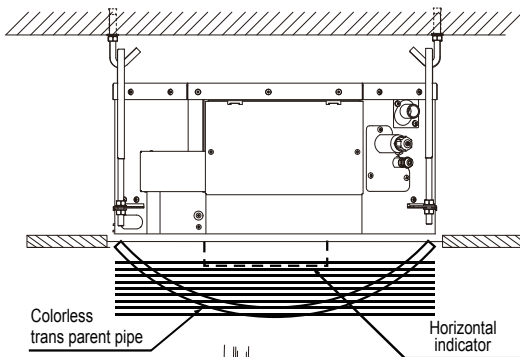

Fig. 5-6

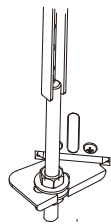

Fig. 5-7

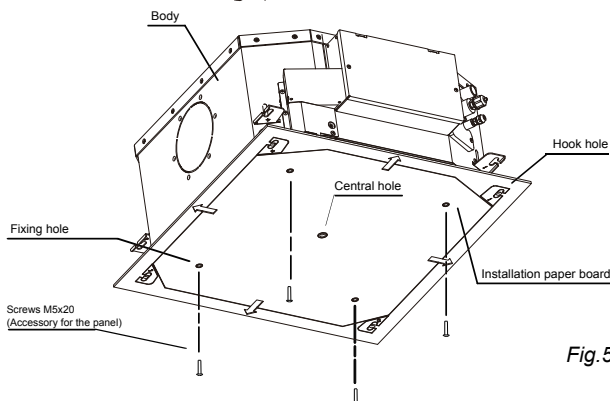

Fig. 5-8



NOTE

All illustrations in this manual are for reference only. They may be slightly different from the air conditioner you purchased (depend on model). The actual shape should be followed.

5.3 Install The Panel



CAUTION

Never put the panel face down on floor or against the wall, or on irregularly shaped objects.

Never drop or strike it.

1 Remove the air inlet grid.

- Slide two grid switches towards the middle at the same time, and then pull them up. (Refer to Fig. 5-9)
- Lift the grid up to an angle of about 45°, and remove it. (Refer to Fig. 5-10)

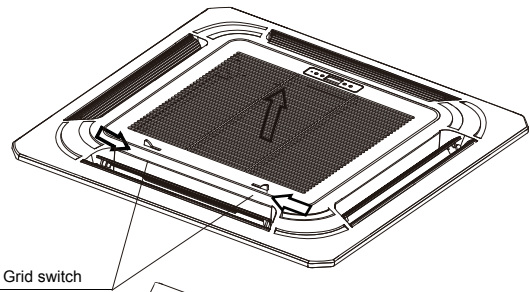

Fig. 5-5

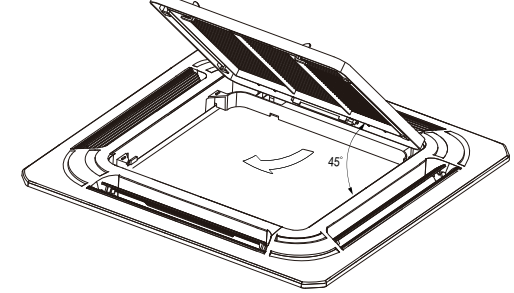

Fig. 5-9

2 Install the panel

- Align the swing motor on the panel to the tubing joints of the body. (Refer to Fig. 5-11)
- Hang the two fixed ropes of the main body to the installation cover and the other cover of the swing motor: (Refer to Fig. 5-11 ① and ②)



CAUTION

The installation cover of the swing motor must sink into the corresponding water pan.

- Install the panel on the main body with bolts (M5×20) and washers. (Refer to Fig. 5-11④)
- Adjust the four panel hook screws to keep the panel horizontal. Screw them into the ceiling evenly.
- Adjust the panel in the direction of the arrow in Fig. 5-11③ slightly to fit the panel's center to the center of the ceiling's opening. Guarantee that the hooks of the four corners are fixed well.

- Keep fastening the screws under the panel hooks until the thickness of sealing sponges 1&2 between the body and the panel's outlet has been reduced to about 4-6mm. The edge of the panel should touch the ceiling well. (Refer to Fig.5-12)
- The fault described in Fig.5-13 can be caused if screws are not tightly fastened
- If the gap between the panel and ceiling still exists after fastening the screws, the height of the indoor unit should be adjusted. (Refer to Fig.5-14-left)

- Modify the height of the indoor unit through the openings on the panel's four corners, if lifting the indoor unit and the drainage pipe is not influenced (Refer to Fig.5-14-right).
- 3 Hang the air inlet grid on the panel. Then connect the lead terminals for the swing motor and control box with the corresponding terminals on the body.
 - 4 Relocate the air inlet grid in the procedure in the reverse order to install it.

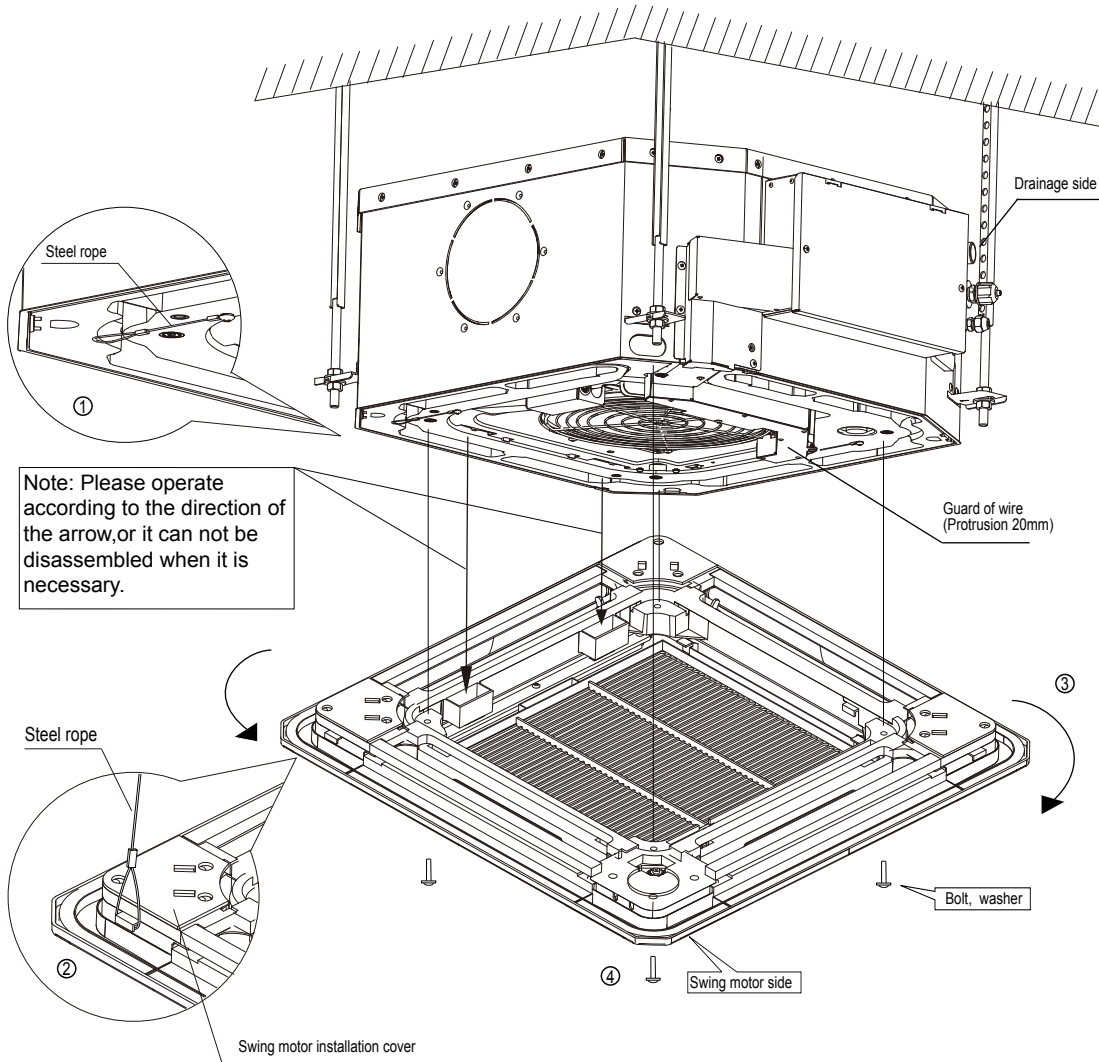

Fig.5-11

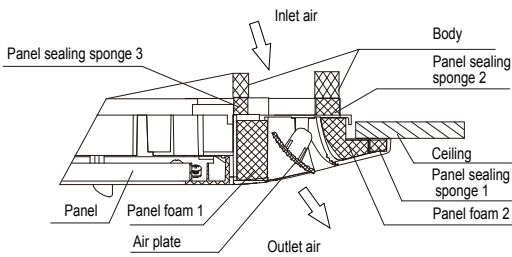

Fig.5-12

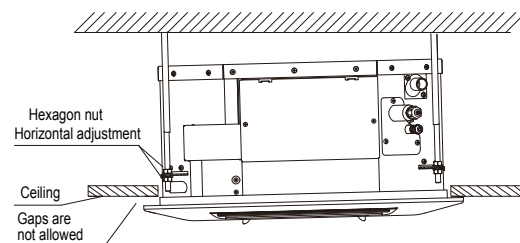

Fig.5-14

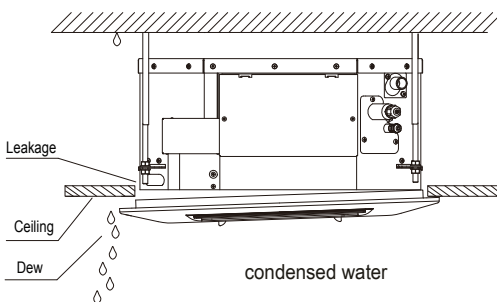

Fig.5-13

5 Panel Installation Instruction



Sleeve

Tighten belt

5.1 Fix the panel to the indoor unit and open the grill, as shown below.



5.2 Put the indoor unit display board wiring and stepper motor wiring into the sleeve.

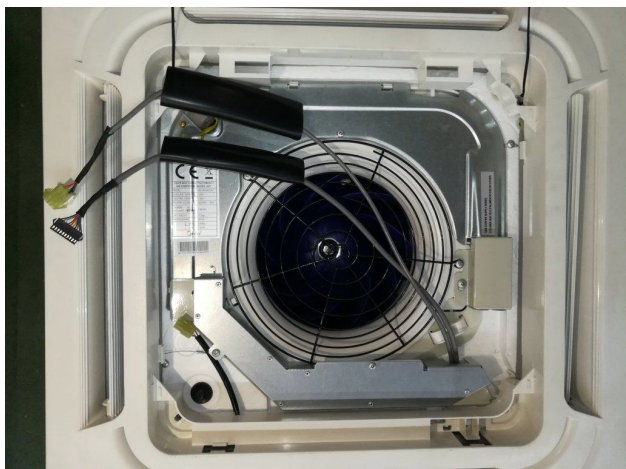

5.3 Connect the wiring between the indoor unit and the panel.



5.4 Move the sleeve to the middle of the wirings and use the tighten belt to tie the sleeve ends tightly. Cut off the extra parts of the tighten belt.

Sketch map of the sleeve bandage:



6. INSTALL THE CONNECTION PIPE

- Check whether the height drop between the indoor unit and outdoor unit, the length of the refrigerant pipe, and the number of the bends meet the following requirements:

- The max height drop and length of refrigerant pipe depend on the outdoor unit. (If the height drop is more than 10000 mm position the outdoor unit above the indoor unit.)
- The number of bends must be fewer than 15.
- Do not let air, dust, or other impurities enter the pipe system during installation.
- The connection pipe should not be installed until the indoor and outdoor units have been fixed.
- Keep the connection pipe dry, and do not let moisture in during installation.

- The Procedure of Connecting Pipes
Measure the necessary length of the connection pipe, and install it as follows.

- Connect the indoor unit before the outdoor unit.
- ① Bend the tubing the correct way. Do not damage them.
- ② Coat the surfaces of the flare pipe and the joint nuts with frozen oil, and turn them for 3-4 rounds with your hands before using a wrench. (Refer to Fig. 6-1)
- ③ Use two wrenches simultaneously when you connect or disconnect the pipes.

- The stop valve of the outdoor unit should be fully closed (as per the original state). Every time you connect the pipes, first loosen the nuts at the stop valve. Then connect the flare pipe (within in 5 minutes). If the nuts have been loose for a long time, dusts and other impurities may enter the pipe system and may cause a malfunction. Expel the air out of the pipe with refrigerant before connection.

- Expel the air (refer to "Expel The Air") after connecting the refrigerant pipe to the indoor and outdoor units. Then fasten the nuts at the repair points.

- Note for Bendable Pipes.

- The bending angle should not exceed 90°C
- The bending position is preferably for the bendable pipe. Larger is better.

- Do not bend the pipe more than three times.

- Bend the connection pipe that has a thin surface.

- Cut out a desired concave at the bending part of the insulating pipe.

- Then expose the pipe (cover it with tape after bending).

- To prevent collapsing or deformation. Bend the pipe at its widest radius.

- Use a bender on low radius pipes.

- Use a normal brass pipe.
Use the same insulating materials for the brass pipe. (More than 9 mm thick).

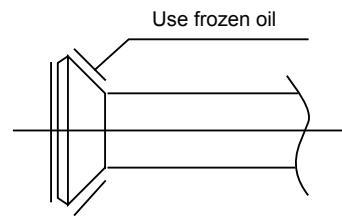
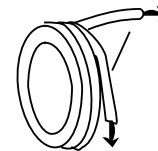

Fig. 6-1

Bend the pipe with your thumb



Fig. 6-2



Use the method for unlocking the coil to straighten the pipe

Fig. 6-3

- Locate The Pipe

- Drill a hole in the wall (suitable just for the size of the wall conduit, 90 mm in general), then set the fittings such as the wall conduit and its cover.
- Bind the connection pipe and the wires together tightly with binding tape. Do not let air in to avoid leaks due to condensation.
- Pass the bound connection pipe through the wall conduit from outside. Be careful of the pipe at all locations and do not damage the tubing.

- Connect the pipes.

- Then, open the stem of the stop valves of the outdoor unit to ensure regular flow in the refrigerant pipe that connects the indoor and outdoor units.

- Check for leaks with a leak detector or soapy water.

- Cover the joint of the connection pipe to the indoor unit with the sound proof/insulation sheath (fittings), and bind it well with the tape to prevent leaks.

7. REFRIGERANT PIPE CONNECTION

7.1 Expel The Air

- Flaring

- Cut a pipe with a pipe cutter.
- Insert a flare nut into a pipe and flare the pipe.

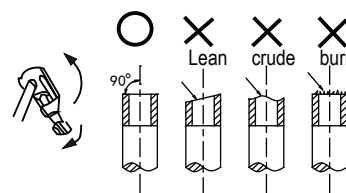

Fig. 7-1

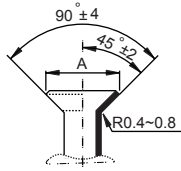

Fig. 7-2

Table.7-1

Outside diameter	A(mm)	
	Max	Min
Φ6.4mm	8.7	8.3
Φ9.5mm	12.4	12.0
Φ12.7mm	15.8	15.4
Φ15.9mm	19.0	18.6
Φ19.1mm	23.3	22.9

■ Fasten the nut

- Put the connection piping at the correct position, fasten the nuts with your hand before using a wrench. (Refer to Fig.7-3)
- Too large torque will harm the bell-mouthing and too small will cause a leak. Determine the torque according to Table.7-2.

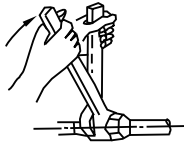

Fig. 7-3

Table. 7-2

Tubing size	Torque
Φ6.4 mm	14.2~17.2 N.m (144~176 kgf.cm)
Φ9.5 mm	32.7~39.9 N.m (333~407 kgf.cm)
Φ12.7mm	49.5~60.3 N.m (504~616 kgf.cm)
Φ15.9mm	61.8~75.4 N.m (630~770 kgf.cm)
Φ19.1mm	97.2~118.6 N.m (990~1210 kgf.cm)

- The necessary filling amount of refrigerant
- The refrigerant volume to be added is calculated according to outdoor unit installation manual. Add refrigerant by measuring it on a scale. L: The length of the pipe
- Please record the quantity added and store it carefully for future maintenance.
- Expel the air with a vacuum pump (Refer to Fig.7-4) (Please refer to its manual for how to use the manifold valve)
- Loosen and remove the maintenance nuts of stop valves A and B, and connect the charge hose of the manifold valve with the maintenance terminals of stop valve A. (Ensure that stop valves A and B are both closed)
- Connect the joint of the charge hose to the vacuum pump.
- Completely open the Lo-lever of the manifold valve.
- Turn on the vacuum pump. At the beginning of pumping, loosen the maintenance terminal nut of stop valve B a little to check whether air comes in. (The sound of the pump changes and compound meter indicator goes below zero). Then fasten the nut.
- When the pumping has finished, completely close the Lo-lever of the manifold valve and turn off the vacuum pump.
- After pumping for at least 15 minutes, confirm that the multimeter indicator is -1.0×10^5 Pa (-76 cmHg)
- Loosen and remove the quadrangle cover on stop valves A and B to open stop valve A and B completely. Then, fasten them.
- Disassemble the charge hose from the repair-mouth of stop valve A, and fasten the nut.

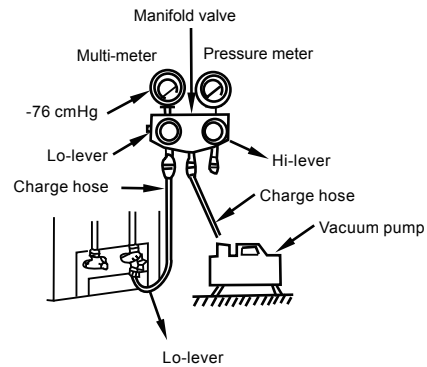

Fig. 7-4

- All the stop valves should be opened before testing. Each air conditioner has two stop valves of different sizes on the side of the outdoor unit, which operate as the Lo-stop value. (Refer to Fig.7-5)

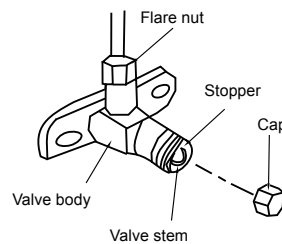

Fig. 7-5

7.2 Check The Leakage

- Check all the joints with the leak detector or soapy water. (Refer to Fig.7-6)

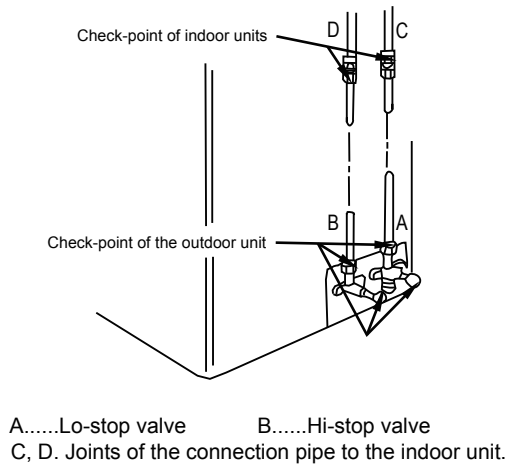

Fig.7-6

7.3 Insulation

- Insulate all exposed parts of the flare pipe joints and refrigerant pipe on the liquid side and gas side. Ensure that there is no gap between them. (Refer to Fig.7-7)
- Incomplete insulation may cause condensation.

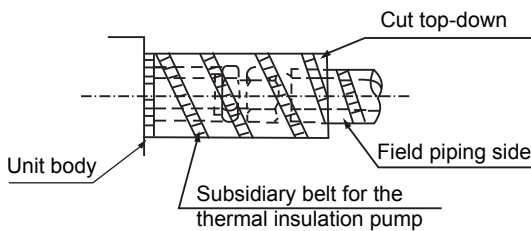

Fig.7-7

8. CONNECT THE DRAINAGE PIPE

8.1 Installing The Drainage pipe Of The Indoor Unit

- The drainage pipe can use PVC pipe. (External diameter 30-32 mm, inner diameter 25 mm.)
- Joint the drainage pipe connector to the end side of water pumping pipe. Fix the drainage pipe to the insulation casing of the water outlet pipe with the clasp from the water outlet pipe (attached).



CAUTION

Don't force water-pumping pipe or you might crack it.

- The water-pumping pipe and drainage pipe from main body must be wrapped evenly with an insulation sheath, and bound by a tightening band for stopping air ingress and coagulation.
- Prevent water backflow from getting inside the unit during shutdown. Place the drainage pipe shall downwards and the drain water to outdoors (the drainage side). The gradient of the drainage pipe should be higher than (1/100) and free from salient or water. (Refer to Fig.8-1 a)

5) When connecting the drainage pipe, do not drag the pipe and thus pull the main unit. To do so, arrange bearing points every 800 to 1000 mm to avoid bending the pipe (Refer to Fig.8-1 b).

6) When connecting a lengthened drainage pipe, apply protective tube to wrap the indoor part to connect it tightly.

7) If the drainage pipe outlet is higher than the pumping connection pipe of the main body, arrange the drainage pipe upwards vertically using the connection assembly of the water outlet for vertical bending. Set the height of the drainage pipe to the water pan surface to no more than 600 mm to avoid excessive backflow and overflow during shutdown. (Refer to Fig.8-2.)

8) Based on pipe bending requirements, use the connection assembly for the water outlet in the terminal box for pipe layout.



CAUTION

The joints in the drainage system must be sealed to avoid water leaks.

9) The height from the floor to the end of drainage pipe or the bottom of drainage slot must be more than 50 mm. Do not immerse the end of drainage pipe or the bottom of drainage slot into water. When draining condensed water to the raceway, bend the drainage pipe into a U-shaped hydroseal to avoid transmitting odor from the drainage pipe indoors.

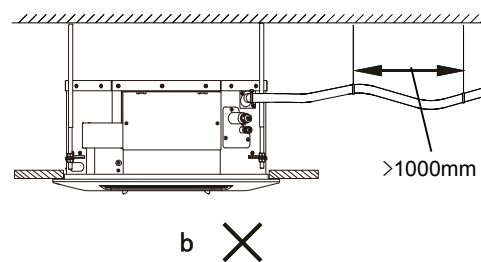
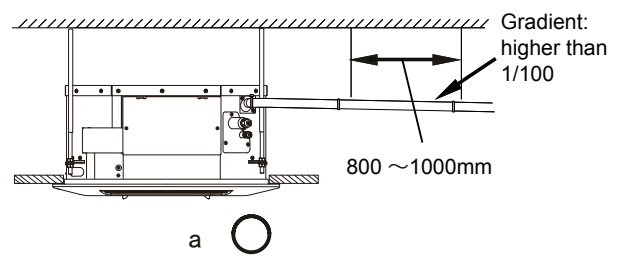

Fig.8-1

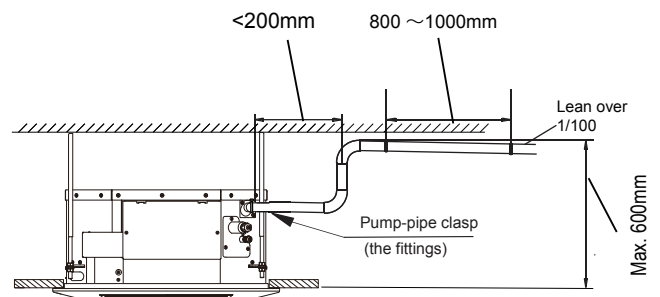

Fig.8-2

8.2 Drainage Test

- Check that the drainage pipe is unhindered
- Newly built house should be tested before decorating the ceiling.
 1. Remove the test cover, and stow 2000 ml of water to the water pan through the stow tube.
 2. Turn on the power. Then, run the air conditioner in "COOLING" mode. Listen to the sound of the drainage pump. Check whether the water discharges well (a lag of 1 min is allowed before discharging, according to the length of the drainage pipe), and check whether water leaks from the joints.

CAUTIONS: If there is a fault, resolve it immediately.

3. Stop the air conditioner for three minutes and check that everything is normal. If the drainage hose is poorly located, water overflow will cause the alarm indicator lamp to flash (for both cooling and heating or cooling only) and water may leak from the water pan.
 4. Check the drainage pump for draining water immediately when the alarm sounds for a high water level. If the water level cannot come back to below the limit, the air conditioner will stop. Restart it until turn off the power and drain all the water.
 5. Turn off the power and drain the water away.
- The drainage plug is used to empty the water pan for maintenance of the air conditioner. Fix it in position at all times when running to avoid leaks.

9. ELECTRICAL CONNECTION

9.1 Electrical wiring



CAUTION

- The power supply of indoor unit must within normal voltage range.
- Before connecting the wire, switch off the power. Otherwise it may cause electric shocks.
- The power wire type designation is H05RN-R / H07RN-F or above.
- External wiring of the indoor unit must be grounded, so the power wire of the outdoor unit must be reliably connected to the external grounding wire.
- Electrical wiring must be performed by an electrician according to the wiring label.
- Before completing the wiring, an all-pole disconnection device must be installed.
- Install the electrical leakage device according to national regulations.
- Arrange power wires and communication wires so they do not interfere with each other. Connection pipes and valves should not come into contact.
- Select an appropriate connection wire according to specification requirements. Do not parallel connect two wires, unless the welding joint is well welded and wrapped with insulating tape.
- Every pole of the all-pole disconnection device should have at least 3 mm separation distance. Install a leakage protector with a rating above 10 mA when completing the wiring.
- When all electrical wiring is completed, power on the unit after confirming that all wires are connected correctly and fixed tightly.

9.2 power wire connection

- The indoor unit and outdoor unit should use separate power supplies, independent leakage protectors and an all-pole disconnection device.
- Indoor units connecting to the same outdoor unit should use a uniform power supply, leakage protection devices and all-pole disconnection device.
- Terminal Board Diagram follow as Fig.9-1

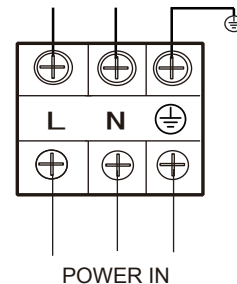

Fig.9-1

9.3 Power Supply Specification

The power supply specifications are as follows. See table 9-1&9-2. If the capacity of the wire is too low, the wire may overheat and the machine may burn out.

Table 9-1

Model(W)		2200~4500
Power	Phase	1-Phase
	volt and frequency	220-240V~ 50Hz 220-240V~ 50/60Hz
Indoor/outdoor connecting wire (Communication wire)		RVVSP 2*AWG16-AWG20
Indoor/wired controller connecting wire (Communication wire)		RVVSP 2*AWG16-AWG20
Fuse on board		5A/250VAC

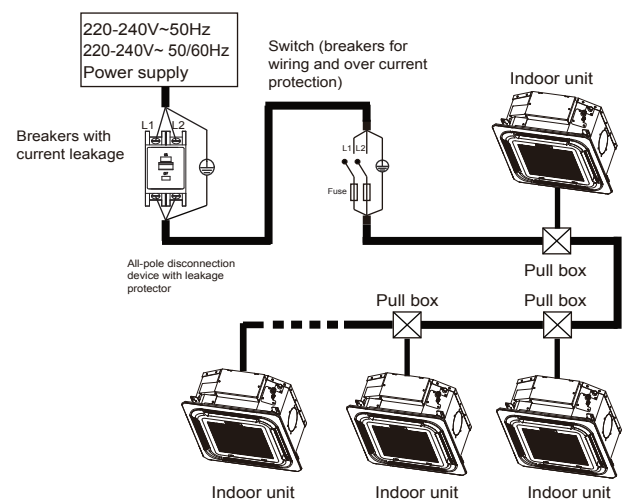

Fig.9-2

Table 9-2 Thickness of main power wire, switch capacities

	Total capacity of Indoor units	Minimum wire thickness (mm ² [AWG])		Switch(A)		Breaker for wiring (A)	Breaker for current leakage
		Main Power Wire	Ground wire	Capacity	Fuse		
indoor unit	< 10A or singel unit	1.3[16]	1.3[16]	15	15	15	15A 10mA 0.1sec. or less
	15A~10A	2.0[14]	2.0[14]	15	15	15	15A 10mA 0.1sec. or less
	20A~15A	3.3[12]	3.3[12]	20	20	20	20A 10mA 0.1sec. or less
	30A~20A	5.2[10]	5.2[10]	30	30	30	30A 10mA 0.1sec. or less
	40A~30A	8.3[8]	8.3[8]	40	40	40	40A 10mA 0.1sec. or less
	50A~40A	13.3[6]	13.3[6]	50	50	50	50A 10mA 0.1sec. or less

NOTE : The chart shown is only for reference. Installation must conform with local regulations.

9.4 Communication Wire Connection

- Use copper core PVC insulated sheathed shielding twisted cord (RVVSP) as communication wire for optimum communication.
- Do not wire or plug in terminal blocks with electricity.
- Communication between the indoor unit and outdoor unit uses RS485 communication. The interface is "P, Q, E". (Refer to Fig. 9-3)
- The shielding layer of the communication wire for the indoor unit and outdoor unit should be connected by hand and then ground at the outdoor unit side at a single point.
- The shielding layer of the communication wire for indoor unit and wired controller should be connected by hand. Finally, it will be grounded at a single point.
- Complete wiring as per the wiring diagram.
- Communication wires must not form a closed loop.
- Do not tie communication wires, refrigerant pipe and power cable together when the communication wires are parallel to the power wire.
- A distance of more than 51 mm should be maintained, to prevent communication interference.
- Use insulated rubber tape to bind bare copper wire to prevent communication failures caused by short circuit.

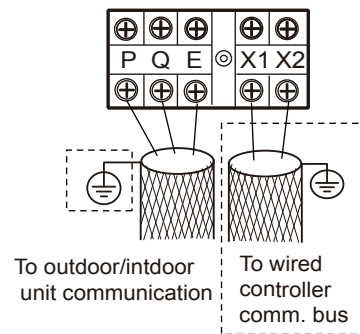
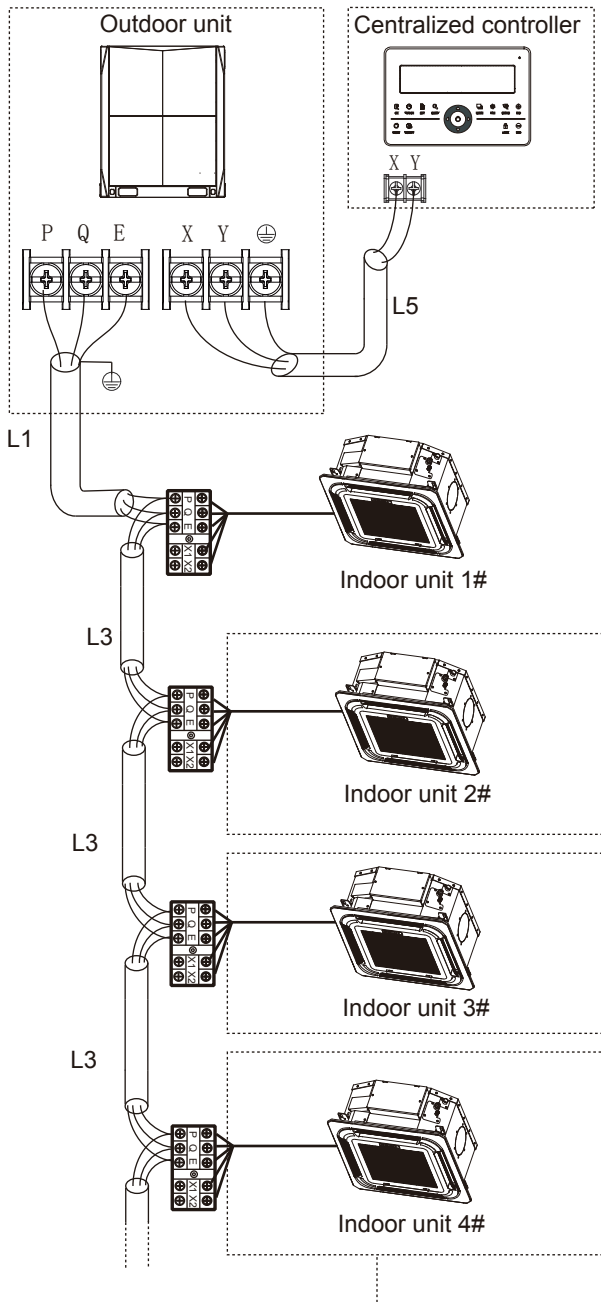

Fig.9-3

Example of communication wiring of the heat pump system



Maximun wiring length
 $L1+L3 \leq 1200\text{ m}$, $L5 \leq 1200\text{ m}$

Fig.9-4



CAUTION

The system can connect 64 indoor units (0-63). Each requires a unique system address. If two indoor units in the same system have the same address, a fault will occur.

1 2

10. CONTROL OPERATION

10.1 Hoursepower

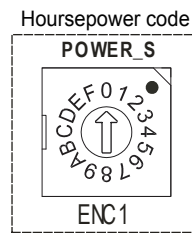

Base on different purposes to setting the switch cords on PC panel of indoor electrical control box. Once finish the setting, please cut off the main power, and then input power again, otherwise, setting function could not work.

Table.10-1

SW7_2 + ENC1	Toggle switch	Set horsepower
	Code	Capacity
	0	2200W
	1	2800W
	2	3600W
	3	4500W
	4	5200W
	F	1700W



CAUTION

There are maximum 64 indoor units in one refrigerant system, and each of them should occupy one unique address, from 0 to 63. Repeated indoor address will result in error.
 Please switch off the power before configuring settings, or an error may occur.

10.2 Network address set

- Network address is set by communication of indoor and outdoor unit; the address is the same as indoor address, there is no need to set separately.

10.3 Main board Code designation

SW1 definition

	<ul style="list-style-type: none"> ● 0 means the cooling mode temperature compensation is 0°C (default) ● 1 means the cooling mode temperature compensation is 2°C
	<ul style="list-style-type: none"> ● 0 means EXV positions 96 (steps) in standby heating mode (default) ● 1 means EXV positions 72 (steps) in standby heating mode

SW2 definition

	Reserved (Default 0)
	Reserved (Default 0)

SW3 definition

	<ul style="list-style-type: none"> ● 0 means auto addressing mode (default) ● 1 means clear indoor unit address
	Reserved (default 0)

SW4 definition

	● 00 means the time for stopping the TERMAL fan is 4 minutes (default)
	● 01 means the time for stopping TERMAL fan is 8 minutes
	● 10 means the time for stopping TERMAL fan is 12 minutes
	● 11 means the time for stopping TERMAL fan is 16 minutes

SW5 definition

	● 00 means shutting down the unit to "stop cold air" at 15°C (default)
	● 01 means shutting down the unit to "stop cold air" at 20°C
	● 10 means shutting down the unit to "stop cold air" at 24°C
	● 11 means shutting down the unit to "stop cold air" at 26°C

SW6 definition

	● 00 means the temp. compensation value is 6°C in heat mode (default)
	● 01 means the temp. compensation value is 2°C in heat mode
	● 10 means the temp. compensation value is 4°C in heat mode
	● 11 means temp. compensation value is 0°C in heat mode (follow me)

SW7 definition

	● Reserved (default 0)
	● Reserved (default 0)

J1 definition

	● Without jumper "J1" for the auto restart function
	● With jumper "J1" for the non-auto restart function

0/1 Definition

	Means 0		Means 1
--	---------	--	---------

10.4 ERROR CODE

Table.10-2

Error Code	Error Content
FE	● No address when first power on
H0	● M-Home not matched error(Reserved)
E0	● Mode conflict
E1	● Communication error of indoor and outdoor units
E2	● Error with the indoor temp. sensor (T1)
E3	● Error with the pipe temp. sensor (T2)
E4	● Error with the pipe temp. sensor (T2B)
E5	● Reserved
E6	● DC FAN error
E7	● EEPROM error
Eb	● Error of electronic expansion valve
Ed	● Outdoor unit error
EE	● Water level alarm

11 . TEST OPERATION



CAUTION

The protection function will delay the startup of compressor for 3 minutes if the unit is turned on immediately after powering on or restarting after shutting down.

- Testing must be carried out after installation is completed.
- Please confirm the following points before the test:
 - The indoor unit and outdoor unit are installed properly.
 - Piping and wiring are completed correctly.
 - The refrigerant pipe system has been checked for leaks.
 - Drainage is unimpeded.
 - The heating insulation works well.
 - The ground wiring is connected correctly.
 - The length of the piping and the amount of recharged refrigerant have been recorded.
 - The power voltage fits the rated voltage of the air conditioner.
 - There is no obstacle at the air outlet and inlet of the outdoor and indoor units.
 - The gas side and liquid side stop valves are both open.
 - Preheated the air conditioner by powering it on.
- According to the user's requirements, install the remote controller frame where the remote controller's signal can reach the indoor unit smoothly.
- Test operation
 - Set the air conditioner in "COOLING" mode with the remote controller. Then check the following points according to the "Owner's Manual". If there is an error, refer to "Troubles And Causes" for a solution.
- The indoor unit
 - Whether the switch on the remote controller works normally.
 - Whether the buttons on the remote controller works well.
 - Whether the air flow louver moves normally.
 - Whether the room temperature is well adjusted.
 - Whether the indicator lights normally.
 - Whether the Manual operation buttons work normally.
 - Whether drainage is normal.
 - Whether there is vibration or abnormal noise during operation.
 - Whether the air conditioner is heating properly in heat pump type units.
- The outdoor unit
 - Whether there is vibration or abnormal noise during operation.
 - Whether the generated wind, noise, or water condensed by the air conditioner have influenced your neighborhood.
 - Whether any of the refrigerant leaks.

NOTE CONCERNING PROTECTION OF ENVIRONMENT



This product must not be disposed of via normal household waste after its service life, but must be taken to a collection station for the recycling of electrical and electronic devices. The symbol on the product, the operating instructions or the packaging indicate such disposal procedures. The materials are recyclable in accordance with their respective symbols. By means of re-use, material recycling or any other form of recycling old appliances you are making an important contribution to the protection of our environment. Please ask your local council where your nearest disposal station is located.

INFORMATION CONCERNING USED REFRIGERANT MEDIUM

This unit is containing fluorinated gases included in the Kyoto protocol. The maintenance and the liquidation must be carried out by qualified personnel.

Type of refrigerant: R410A

The composition of the cooling medium R410A: (50% HFC-32, 50% HFC-125)

The quantity of the refrigerant: please see the unit label.

The value GWP: 2088 (1 kg R410A = 2,088 t CO₂ eq)

GWP = Global Warming Potential

In case of quality problem or other please contact your local supplier or authorized service center.

Emergency number: 112

PRODUCER

SINCLAIR CORPORATION Ltd.

1-4 Argyll St.

London W1F 7LD

Great Britain

www.sinclair-world.com

This product was manufactured in China (Made in China).

REPRESENTATIVE

SINCLAIR Global Group s.r.o.

Purkynova 45

612 00 Brno

Czech Republic

TECHNICAL SUPPORT

SINCLAIR Global Group s.r.o.

Purkynova 45

612 00 Brno

Czech Republic

Tel.: +420 800 100 285

Fax: +420 541 590 124

www.sinclair-solutions.com

info@sinclair-solutions.com

