

CONTROL BOX FAN COIL UNIT

INSTALLATION AND
USER MANUAL

FCUKZ-03



sinclair
AIR CONDITIONING

“Original instructions”

CONTENTS

PAGE

PRECAUTIONS.....	1
INSTALLATION INFORMATION.....	2
ATTACHED FITTINGS.....	3
INSTALLATION METHOD&DIMENSION.....	3
ELECTRICAL WIRING.....	4
APPLICALTION CONTROL.....	6
TROUBLE SHOOTING.....	7
ATTACHED: Condenser Temp.sensor Installation Guide.....	7
APPENDIX.....	8

1. PRECAUTIONS

- Be sure to be in conformity with the local, national and international laws and regulations.
- Read "PRECAUTIONS" carefully before installation.
- The following precautions include important safety items. Observe them and never forget.
- Keep this manual in a handy place for future reference.

The safety precautions listed here are divided into two categories. In either case, important safety information is listed which must be read carefully.



WARNING

Failure to observe a warning may result in death.



CAUTION

Failure to observe a caution may result in injury or damage to the equipment.

After completing the installation, make sure that the unit operates properly during the start-up operation. Please instruct the customer on how to operate the unit and keep it maintained. Also, inform customers that they should store this installation manual for future reference.



WARNING

Be sure only trained and qualified service personnel to install, repair or service the equipment.

Improper installation, repair, and maintenance may result in electric shocks, short-circuit, leaks, fire or other damage to the equipment.

Install according to this installation instructions strictly.

If installation is defective, it will cause water leakage, electric shock, fire.

When installing the unit in a small room, take measures against to keep refrigerant concentration from exceeding allowable safety limits in the event of refrigerant leakage.

Contact the place of purchase for more information. Excessive refrigerant in a closed ambient can lead to oxygen deficiency.

Use the attached accessories parts and specified parts for installation.

Otherwise, it will cause the set to fall, water leakage, electric shock, fire.

Install at a strong and firm location which is able to withstand the set's weight.

If the strength is not enough or installation is not properly done, the set will drop to cause injury.

Before obtaining access to terminals, all supply circuits must be disconnected.

The appliance must be positioned so that the plug is accessible.

The enclosure of the appliance shall be marked by word, or by symbols, with the direction of the fluid flow.

For electrical work, follow the local national wiring standard, regulation and this installation instructions. An independent circuit and single outlet must be used.

If electrical circuit capacity is not enough or defect in electrical work, it will cause electric shock, fire.

Use the specified cable and connect tightly and clamp the cable so that no external force will be acted on the terminal.

If connection or fixing is not perfect, it will cause heat-up or fire at the connection.

Wiring routing must be properly arranged so that control board cover is fixed properly.

If control board cover is not fixed perfectly, it will cause heat-up at connection point of terminal, fire or electric shock.

If the supply cord is damaged, it must be replaced by the manufacture or its service agent or similarly qualified person in order to avoid a hazard.

An all-pole disconnection switch having a cintract separation of at least 3mm in a poles should be connected in fixed wiring.

When carrying out piping connection, take care not to let air substances go into refrigeration cycle.

Otherwise, it will cause lower capacity, abnormal high pressure in the refrigeration cycle, explosion and injury.

Do not modify the length of the power supply cord or use of extension cord, and do not share the single outlet with other electrical appliances.

Otherwise, it will cause fire or electric shock.

Carry out the specified installation work after taking into account strong winds, typhoons or earthquakes.

Improper installation work may result in the equipment falling and causing accidents.

If the refrigerant leaks during installation, ventilate the area immediately.

Toxic gas may be produced if the refrigerant comes into the place contacting with fire.

After completing the installation work, check that the refrigerant does not leak.

Toxic gas may be produced if the refrigerant leaks into the room and comes into contact with a source of fire, such as a fan heater, stove or cooker.



CAUTION

Ground the air conditioner.

Do not connect the ground wire to gas or water pipes, lightning rod or a telephone ground wire. Incomplete grounding may result in electric shocks.

Be sure to install an earth leakage breaker.

Failure to install an earth leakage breaker may result in electric shocks.

Connect the outdoor unit wires , then connect the indoor unit wires.

You are not allow to connect the air conditioner with the power source until including wiring and piping the air-conditioner is done.

While following the instructions in this installation manual, install drain piping in order to ensure proper drainage and insulate piping in order to prevent condensation.

Improper drain piping may result in water leakage and property damage.

Install the indoor and outdoor units, power supply wiring and connecting wires at least 1 meter away from televisions or radios in order to prevent image interference or noise.

Depending on the radio waves, a distance of 1 meter may not be sufficient enough to eliminate the noise.

The appliance is not intended for use by young children or infirm persons without supervision.

Young children should be supervised to ensure that they do not play with the appliance.

Don't install the control box in the following locations:

- There is petrolatum existing.
- There is salty air surrounding (near the coast).
- There is caustic gas (the sulfide, for example) existing in the air (near a hot spring).
- The Volt vibrates violently (in the factories).
- In buses or cabinets.
- In kitchen where it is full of oil gas.
- There is strong electromagnetic wave existing.
- There are inflammable materials or gas.
- There is acid or alkaline liquid evaporating.
- Other special conditions.

2. INSTALLATION INFORMATION

- **To install properly, please read this "installation manual" at first.**
- **The control box must be installed by qualified persons.**
- **If the control box is installed on a metal part of the building, it must be electrically insulated according to the relevant standards to electrical appliances.**
- **When all the installation work is finished, please turn on the power only after a thorough check.**
- **Regret for no further announcement if there is any change of this manual caused by product improvement.**





INSTALLATION ORDER

- Select the location;
- Install the indoor unit;
- Install the outdoor unit;
- Install the connecting pipe ;
- Connect the drain pipe;
- Wiring;
- Test operation.

3. ATTACHED FITTINGS

Please check whether the following fittings are of full scope. If there are some spare fittings , please restore them carefully.

Table 3-1

NAME	SHAPE	QUANTITY	FUNCTION
1. Screw ST3.9x25 and Plastic expansion pipe for installation board		4+4	Secure the installation board
2. Temp.sensor		1	_____
3. Condenser Temp.sensor		1*	_____
4. Wire controller		1	_____
5. Installation&owner's manual	_____	1	_____
6. Wire controller installation manual	_____	1	_____

* FCUKZ-03: Condenser Temp.sensor number is 1;

4. INSTALLATION METHOD & DIMENSION

FCUKZ-03

(Units: mm)

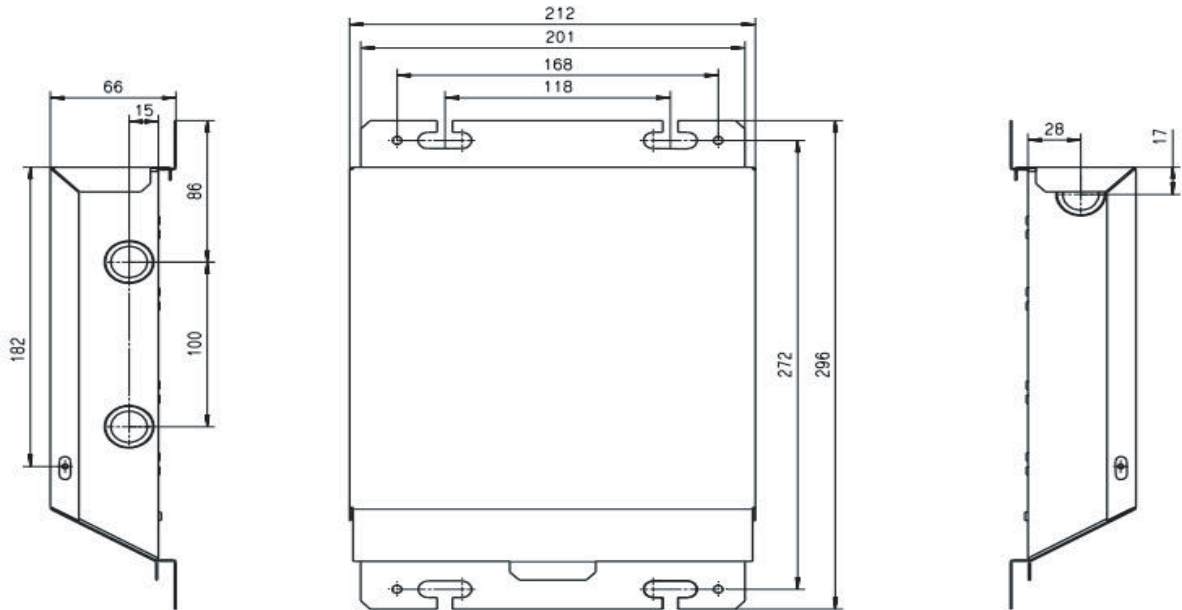

↑
Install vertically

Installation method : Hanging

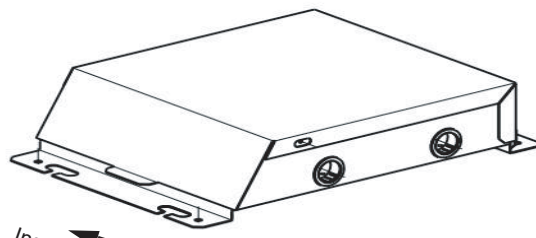

←
Install horizontally

Installation method : Hoisting

Fig 4-1



NOTE

- As hanging installation please use Screw ST3.9x25 for installation.
- As hanging installation, the box should be vertical, and as hoisting installation, it should be installed horizontally, and prohibit to be sloped, inverted.
- All the pictures in this manual are for explanation purpose only. They may be slightly different from the Control Box Type you purchased(depend on model).The actual shape shall prevail.

5. ELECTRICAL WIRING



CAUTION

- The air conditioner should use separate power supply with rated voltage.
- The external power supply to the air conditioner should have ground wiring, which is linked to the ground wiring of the indoor and outdoor unit.
- The wiring work should be done by qualified persons according to circuit drawing.
- The fixed connecting lines must equip with at least 3mm electric shock spacing.
- A leakage protector should be installed according to the National Standard concerning electrical appliance.
- Be sure to locate the power wiring and the signal wirings well to avoid cross-disturbance and their contact with connecting pipe or stop valve body. Generally, do not twist two wiring together unless the joint is soldered well and covered with insulator tape.
- Do not turn on the power until you have checked carefully after wiring.

5.1 The specification of power

The specification of power as the follow display figure, if the capacity is too small will lead to over heat of the wiring, and cause burning of the machine accident.

Table 5-1

Model		FCUKZ-03
Power	Phase	Single-phase
	Voltage and Frequency	220-240V ~ 50/60Hz



CAUTION

The air-gap notch in the circuit breaker is used for insulating the flexible conductor, so that must respond to the related national wire requests to connect to the fixed circuit.

5.2 Electric control box wiring figure



CAUTION

- FCUKZ-03 adopts one valve switch
- T1 is indoor temperature sensor, install to the air inlet of the indoor unit.
- T2-COOL,T2-HEAT is pipe temperature sensor, install to the intermediate of temperature evaporator.

The picture is for reference only, please refer to the actual board.

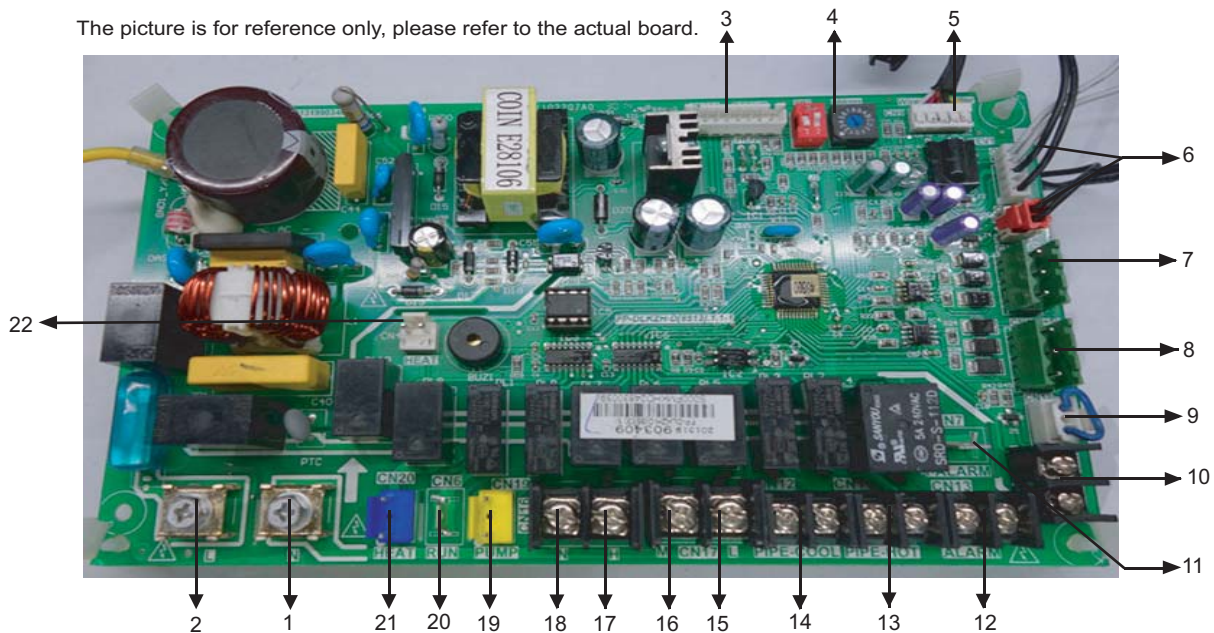

Fig 5.1

5.3 Electric control schematic diagram of the unit

5.3.1 Schematic diagram of connection and communication of the main unit and subordinate units (see Attached Picture)

5.3.2 Indicating diagram of electric control of main control board (see Fig 5.1)

5.4 Detail description for parts in table 5-2

Table 5-2





































No.	Detail information																							
1、 2	*L: Live wire *N: Neutral wire Power in, 220V-240V ~ 50Hz/60Hz																							
3	CN300:DEBUG PORT																							
4	<p>SW2, ENC1: Network address set:Every air-conditioner in network has only one network address to distinguish each other.the set range is 0-63.please see the table blow.</p> <table border="1" data-bbox="525 636 1056 996"> <thead> <tr> <th colspan="3">Toggle switch set</th> <th rowspan="2">Network address code</th> </tr> <tr> <th>SW2</th> <th colspan="2">ENC2</th> </tr> </thead> <tbody> <tr> <td></td> <td></td> <td></td> <td>00~15</td> </tr> <tr> <td></td> <td></td> <td></td> <td>16~31</td> </tr> <tr> <td></td> <td></td> <td></td> <td>32~47</td> </tr> <tr> <td></td> <td></td> <td></td> <td>48-63</td> </tr> </tbody> </table>	Toggle switch set			Network address code	SW2	ENC2					00~15				16~31				32~47				48-63
Toggle switch set			Network address code																					
SW2	ENC2																							
			00~15																					
			16~31																					
			32~47																					
			48-63																					
5	CN9: Connect to Wire cotroller.																							
6	<p>CN5: T1: Room temperature sensor (fault,The wire controller light will be flashes two times at 2Hz, stop 2s).</p> <p>CN5: T2-COOL: Pipe temperature sensor of the condenser(fault,The wire controller light will be flashes three times at 2Hz, stop 2s).</p> <p>*CN8: Pipe temperature sensor of the condenser(fault,The wire controller light will be flashes three times at 2Hz, stop 2s).</p>																							
7	<p>CN10: MODBUS RTU port:Connect to upper unit.Interconnected with P, Q and E of used for RS-485 communication. Please adopts to the shielded twisted-pair wire, and connectthe shielded layer to E.</p> 																							
8	<p>CN14: 485 Communication port :Connect to Centralized Controller. Please adopts to the shielded twisted-pair wire,and connect the shielded layer to E.</p> 																							
9	CN18: Water-level switch(fault:The wire controller light will be flashes four times at 2Hz, stop 2s)																							
10	CN3: ON / OFF Port: Disconnect, the long-distance control function is invalid.When connect,the wire controller and Centralized Controller is invalid and the system is equivalent of shutdown.																							
11	CN7: I-ALARM Port: High voltage signal output,when the system run normal (SRTONG AC signal output).																							
12	CN13: ALARM Port: High voltage signal when a alarm output (SRTONG AC signal output).																							
13																								

Table 5-2

14	CN12 : PIPE-COOL Port:Cool water valve,using in CE-FCUKZ-03 systems in central air conditioning (SRTONG AC signal output).
15	CN17 : L: Connect to indoor FAN unit,low fan speed(SRTONG AC signal output).
16	CN17 : M: Connect to indoor FAN unit,medium fan speed(SRTONG AC signaloutput).
17	CN16 : H: Connect to indoor FAN unit,high fan speed(SRTONG AC signal output).
18	CN16 : N: Connect to Neutral wire.
19	CN19: PUMP(SRTONG AC signal output). 1) After receiving start-up instruction and set in COOL,DRY mode, the pump will be started up instantly, and will maintain start-up state always in the process of operation. 2) To turn it off or transferred to other mode, the pump will be shut down 3 minutes after all modules stop operating.
20	CN6: RUN: High voltage signal output when the system run normal(SRTONG AC signal output).
21	CN20: HEAT(SRTONG AC signal output). Attention: the control port value of the CN20(HEAT) is SRTONG AC signal output but can not direct drive electric heating. so special attention should be paid when installing this heat. Electric heating needs to be connected with 220V-240V ~ power supply externally.
22	CN4: HEAT(DC +12V output). Attention: the control port value of the CN4(HEAT) actually detected is DC 12V signal output and can not direct drive electric heating, so special attention should be paid when installing this heat. DC +12V control signal output by PCB can start/stop the external relay, thereby to start/stop e-heating pipe. Electric heating needs to be connected with 220V-240V ~ power supply externally.

* CE-FCUKZ-03: Condenser Temp.sensor number is 1;

*L、N Port:Strongly recommend using Ring Terminal or Spade Terminal to connect.

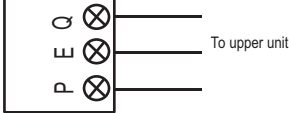
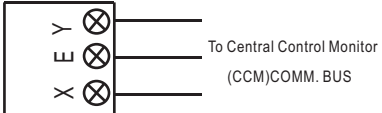

CAUTION

Faults

When the main unit suffers faults, the main unit stops operating, and all other units also stop running;
When the subordinate unit suffers faults, only the unit stops operating, and other units are not affected.

6. APPLICATION CONTROL

6.1 Fan speed adjustment function 3 files

Available wire controller to select high, medium and low three operation modes.

6.3 Centralized control

Centralized control through the CCM03, please refer to the "Centralized control owner's & Installation Manual" .

6.2 Long-dlstance control and alarm functions

- Refer wiring diagram connected CN13 port to achieve fault alarm function.
- Through regulating CN3 port status to realize long-dlstance control function.
 - When CN3 Disconnect, the long-dlstance control function is invalid;
 - When CN3 connect,the wire controller and Centralized Controller is invalid and the system is equivalent of shutdown.

7. TROUBLE SHOOTING

7.1 Troubles and causes of remote controller

Before asking for serving or repairing , check the following points.(see in table 7-1)

Table 7-1

table 7-1

Symptoms	Causes	Solution
Unit does not start	<ul style="list-style-type: none"> Power failure. Power switch is off. Fuse of power switch may have burned. Batteries of remote controller exhausted or other problem of controller. 	<ul style="list-style-type: none"> Wait for the comeback of power. Switch on the power. Replace the fuse. Replace the batteries or check the controller.
The fan speed can not be changed.	<ul style="list-style-type: none"> Check whether the MODE indicated on the wire controller monitor is "DRY". 	When dry operation is selected,the air conditioner automatically change the fan speed. The fan speed can be selected selected during "COOL", "FAN" and "HEAT".
Air flowing normally but completely can't cooling	<ul style="list-style-type: none"> Temperature is not set correctly. 	<ul style="list-style-type: none"> Set the temperature properly.
Low cooling effect	<ul style="list-style-type: none"> Indoor unit heat exchanger is dirty. The air filter is dirty. Inlet of indoor units is blocked. Doors and windows are open Sunlight directly shine. Too much heat resource. 	<ul style="list-style-type: none"> Clean the heat exchanger. Clean the air filter. Eliminate all dirties and make air smooth. Close doors and windows. Make curtains in order to shelter from sunshine. Reduce heat source.
Low heating effect	<ul style="list-style-type: none"> Doors and windows not completely closed. 	<ul style="list-style-type: none"> Use heating device. Close doors and windows.

7.2 Malfunctions and malfunction code

If anything happens like the situation described below, please shut off the power supply of the unit and contact with the customer service center immediately (use wire controller: KJR-90A-E) .

Table 7-2

NO.	Malfunction	The Wire controller light
0	Normal	on
1	EEPROM malfunction	flashes one times at 2Hz, stop 2s
2	Room temperature sensor checking channel is abnormal	flashes two times at 2Hz, stop 2s
3	Evaporator sensor checking channel is abnormal (four-pipe water system COOL MODE:T2-COOL HEAT MODE:T2-HEAT)	flashes three times at 2Hz, stop 2s
4	Water-level switch malfunction	flashes four times at 2Hz, stop 2s

8 ATTACHED (I) Condenser Temp.sensor Installation Guide

8.1 Put Condenser Temp.sensor close to the pipe

- FCUKZ-03

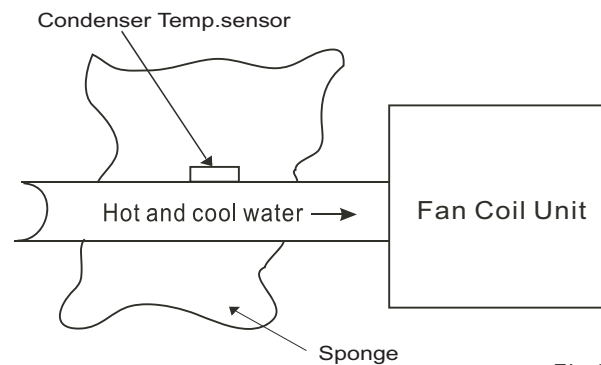

Fig 8.1

8.2 Pack the Condenser Temp.sensor with sponge

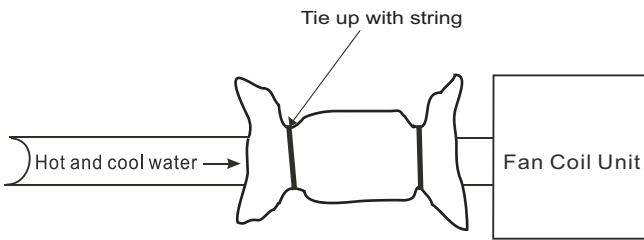
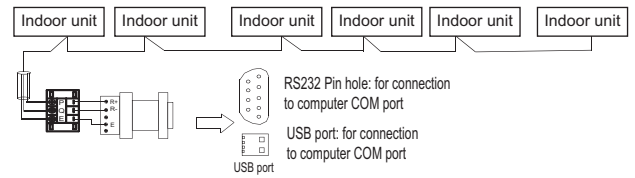

Fig 8.3



- 2) Use RS232 Pin hole or use RS485 to USB convertor to connect indoor unit each other.
- 3) Interconnected with PQE of used for RS-485 communication.

APPENDIX 1: Electric Wiring Diagram

Centralized Controller wiring instruction

- 1) Wiring diagram of building network air conditioning system.

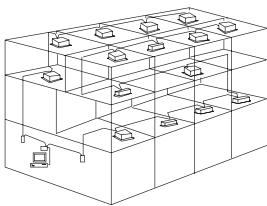

Wiring diagram with good communication effect

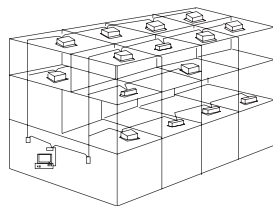

Wiring diagram with poor communication effect (not recommended because it may lead to poor communication)

- 2) System wiring diagram of centralized monitoring and indoor unit of air conditioner.

Both of the following wiring modes of centralized monitor and indoor unit are applicable: (Quantity of indoor units connected with each centralized monitor is less than or equal to 64).

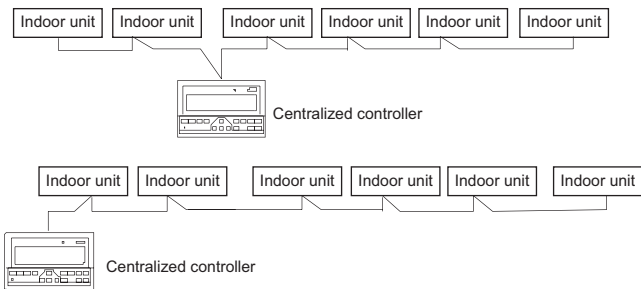

- 3) Interconnected with XYE of used for RS-485 communication.

Communication interface with computer wiring instruction

- 1) System wiring diagram of computer and indoor unit of air-con.

Both of the following wiring modes of computer monitor a indoor unit are applicable. (Quantity of indoor units connected with each centralized monitor is less than or equal to 64).

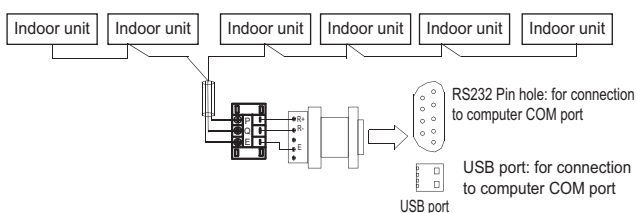

Electric wiring



CAUTION

1. Use special power supply for the air conditioner. Design power supplies specific to the indoor unit .The supply voltage must comply with the nominal voltage.
2. The external supply circuit of the air conditioner must have a ground wire, and the power supply ground wire of the indoor unit must be connected with the external ground wire firmly.
3. The wiring must be performed by professional technicians according to the circuit diagram.
4. Distribute the wires according to the relevant electric technical standards promulgated by the State.
5. The power wire and the signal wire shall be laid out neatly and properly, without mutual interference or contacting the connection pipe or valve.
6. No power cable is attached to this equipment. The user can select the power cable by reference to the stipulated power supply specifications. No joint of wires is allowed.
7. Upon completion of wire connection, double check it and then connect the power supply.

APPENDIX 2 : MODBUS Mapping Table

Table 1: Address mapping table of register in fan coil

The following addresses can be used: 03H, 04H(read), 06H (write in a single register), 10H(write in multiple holding register)			
Data content	Register address	Remark	
Running mode setting	1601 (PLC: 41602)	0x00: OFF mode 0x01: FAN mode 0x02: COOL mode 0x03: HEAT mode 0x04: DRY mode 0x05: AUTO mode When setting other parameters, returning to abnormal data function code. If write this register alone, the defaulted setting is middle speed air.	
Temperature setting Ts	1602 (PLC: 41603)	Set temperature in a normal range, if the setting out of range, it will return to abnormal code 03. Temperature range is 17-30℃ When in Air supply and DRY mode, Ts can't be set. If inquire Ts, it is 0.	
Air speed setting	1603 (PLC: 41604)	0x02: Low speed 0x03: Middle speed 0x04: High speed 0x05: Auto speed When setting other parameters, returning to abnormal data function code.	
Indoor unit temp. T1	1604 (PLC: 41605)	0~240 means -20~100℃ Calculation method: (temp.+5) *2+30 *This register can only read, but can't write	
Cold water coil temp. T2-C	1605 (PLC: 41606)		
Hot water coi; temp. T2-H	1606 (PLC: 41607)		
Timer on	1610 (PLC: 41611)	Number 0~96 means: 0h timing to 24h timing	
Timer off	1611 (PLC: 41612)	Number 0~96 means: 0h timing to 24h timing	
Lock icon	1612 (PLC: 41613)	Bit 0	Lock remote controller: 1: yes 0: no
		Bit 1	00: Lockout shutdown or no lockout
		Bit 2	01: Lockout cooling 10: Lockout heating
Water pump status	1613 (PLC: 41614)	Bit0 drain water pump 1: open 0: close	
		Except for the 2 bits above, other bits in this byte are 0. This byte is read only.	
Coil error status	1614 (PLC: 41615)	Bit 14	E6 Water level detection error
		Bit 8	E8 Air speed detection out of control
		Bit 7	E7 EEPROM error
		Bit 4	E4 T2-HEAT sensor error
		Bit 3	E3 T2-COOL sensor error
		Bit 2	E2 T1 sensor error
Except for the 2 bits above, other bits in this byte are 0.			
Protection status	1615 (PLC: 41616)	Bit 1	P1:Cold air proofing it defrosting protection
		Except for the 1 bit above, other bits in this byte are 0.	
Baud rate	1640 (PLC: 41641)	Support the following baud rate: 4800、9600、19200、38400	After changing the 3 parameters, it needs to correspond to the changed serial port in next communication, otherwise communication will fail. When powering on, recover to default setting: 9600BPS /NO CHECK/ONE STOP
Parity bit information	1641 (PLC: 41642)	No parity: 0x02 Odd-parity check 0x01 Even-parity check 0x00	
Stop bit information	1642 (PLC: 41643)	One stop bit: 0 Two stop bit: 1	

NOTE CONCERNING PROTECTION OF ENVIRONMENT



This product must not be disposed of via normal household waste after its service life, but must be taken to a collection station for the recycling of electrical and electronic devices. The symbol on the product, the operating instructions or the packaging indicate such disposal procedures. The materials are recyclable in accordance with their respective symbols. By means of re-use, material recycling or any other form of recycling old appliances you are making an important contribution to the protection of our environment. Please ask your local council where your nearest disposal station is located.

In case of quality problem or other please contact your local supplier or authorized service center.
Emergency number: 112

PRODUCER

SINCLAIR CORPORATION Ltd.
1-4 Argyll St.
London W1F 7LD
Great Britain

www.sinclair-world.com

This product was manufactured in China (Made in China).

REPRESENTATIVE

SINCLAIR EUROPE spol. s r.o.
Purkynova 45
612 00 Brno
Czech Republic

TECHNICAL SUPPORT

NEPA spol. s r.o.
Purkynova 45
612 00 Brno
Czech Republic

Tel.: +420 800 100 285
Fax: +420 541 590 124

www.sinclair-solutions.com
info@sinclair-solutions.com

